

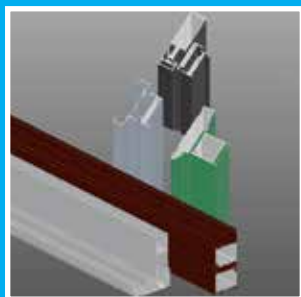

# HYUNDAI ALUMINUM VINA

Technology for a better tomorrow



# Mục Lục - Table Of Content

|   |     |
|---|-----|
| <b>GIỚI THIỆU TẬP ĐOÀN VÀ CÔNG TY</b> .....                         | 4   |
| <b>DÂY CHUYỀN SẢN XUẤT</b> .....                                    | 10  |
| <b>GIỚI THIỆU SẢN PHẨM</b> .....                                    | 20  |
| <b>HỆ CỬA ĐI</b> .....  | 28  |
| Cửa xếp trượt hệ 55.....  | 29  |
| Cửa đi mở quay hệ 65.....   | 31  |
| Cửa đi hệ 70.....   | 34  |
| Cửa đi hệ 100.....  | 37  |
| Cửa mở xoay và cố định hệ 100.....                                  | 41  |
| Cửa đi và cố định hệ HD55.....                                      | 43  |
| Cửa đi và cửa sổ hệ HD55.....                                       | 45  |
| Cửa đi và cố định hệ HD450.....                                     | 46  |
| Cửa đi và cửa sổ hệ HD4400.....                                     | 49  |
| <b>Cửa trượt và cố định</b> .....                                   | 52  |
| Cửa trượt và cố định hệ 80.....                                     | 52  |
| Cửa trượt và cố định hệ 90.....                                     | 56  |
| Cửa trượt và cố định hệ 110.....                                    | 61  |
| Cửa trượt và cố định hệ HD93.....                                   | 66  |
| Cửa trượt và cố định hệ HD95.....                                   | 70  |
| Cửa trượt và cố định hệ HD2600.....                                 | 72  |
| <b>Hệ cửa mở lật</b> .....  | 74  |
| Cửa lật và cố định hệ 70 - 80 - 100 - 120.....                      | 75  |
| Cửa mở lật và cố định hệ HD55.....                                  | 87  |
| <b>Hệ mặt dựng</b> .....  | 90  |
| Mặt dựng hệ 80 - 100 - 120 - 130 - 135 - 145(sevt) - 150 - 195..... | 91  |
| Mặt dựng HDPT.....  | 116 |
| Mặt dựng hệ 160 (united).....                                       | 121 |
| Mặt dựng hệ 160 (unit).....   | 122 |
| Mặt dựng hệ 160 (unit).....   | 123 |
| Mặt dựng cách nhiệt hệ 150.....                                     | 124 |
| Profile mặt dựng.....   | 126 |
| Nắp chụp và trang trí.....  | 132 |
| Profile mở lật.....   | 133 |
| Nẹp giữ kính.....   | 135 |
| Panel profile.....  | 139 |
| Ke góc, ke U, bản mã nhôm, vách ngăn và nan chớp.....               | 141 |
| Biến dạng hộp, hộp đặc, biến dạng tròn, ke V.....                   | 145 |
| <b>Indonesia profile</b> .....                                      | 151 |
| Shop front 3 inch assembly.....                                     | 152 |
| Shop front 4 inch & swing door assembly.....                        | 155 |
| Swing door.....   | 158 |
| Sliding door.....   | 159 |
| Sliding window.....   | 163 |
| Casement window.....  | 167 |
| Economic curtain wall.....  | 169 |
| Louver & round pipe.....  | 171 |
| <b>Hyundai color code</b> .....                                     | 172 |
| <b>Công trình đã làm</b> .....                                      | 173 |
| <b>Hệ thống đại lý</b> .....  | 178 |







**Công nghệ làm nên**

**Tương lai phần vinh !!!**



# GIỚI THIỆU TẬP ĐOÀN VÀ CÔNG TY

## I. Giới thiệu tập đoàn:

- Tập đoàn ALUKO được cấu thành từ 6 công ty con gồm Aluko, Hyundai Aluminum, Gogang Aluminum, Alutec, KPTU và Hyundai Aluminum Vina, tạo nên sức mạnh tổng hợp tối cao từ các công ty gia đình.
- Là doanh nghiệp duy nhất tại Hàn Quốc nắm giữ hệ thống **ONE-STOP**: Tạo khuôn - Đùn ép - Đúc - Sơn - Gia công - Lắp đặt - Thi công - Duy tu bảo dưỡng, bằng công nghệ vật liệu, kỹ thuật đùn ép và công nghệ gia công, lắp đặt, chúng tôi mang tới cho khách hàng một sản phẩm nhôm cường độ cao siêu nhẹ hoàn hảo nhất.



### 1. Hyundai Aluminum Vina

Đường B2, khu B, KCN Phố Nối A, xã Lạc Hồng, huyện Văn Lâm, tỉnh Hưng Yên, Việt Nam

### 2. Alutec Vina

Lô CN6, KCN Điềm Thụy, xã Điềm Thụy, Huyện Phú Bình, tỉnh Thái Nguyên, Việt Nam

### 3. ALK Vina

Lô CN6-1,3, KCN Điềm Thụy, xã Hồng Tiến, tx Phố Yên, tỉnh Thái Nguyên, Việt Nam

### 4. KPTU Vina

Lô CN6, KCN Điềm Thụy, xã Điềm Thụy, Huyện Phú Bình, tỉnh Thái Nguyên, Việt Nam

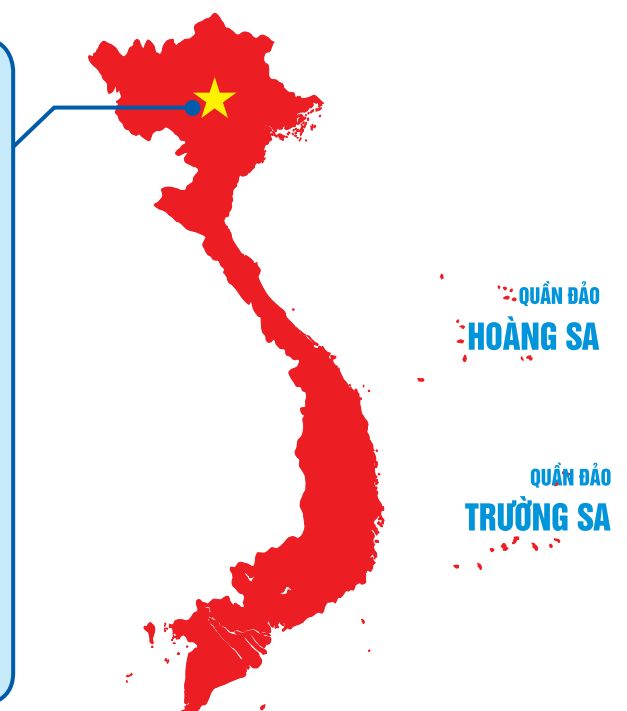



## II. Lịch sử hình thành và phát triển:

### Giai đoạn I: Thành lập công ty Hyundai Aluminum Vina

- Vị trí: KCN Phố Nối A, tỉnh Hưng Yên
- Diện tích nhà máy: 100.048 m<sup>2</sup>
- Giấy chứng nhận đầu tư cấp ngày: 30/10/2006
- Ngày bắt đầu hoạt động: 08/01/2007
- Tổng vốn đầu tư: 132.000.000 USD



### Giai đoạn II: Thành lập tổ hợp công ty Alutec Vina, KPTU Vina, ALK Vina

- Vị trí: KCN Diềm Thụy, tỉnh Thái Nguyên
- Diện tích nhà máy: 175.000 m<sup>2</sup>
- Giấy chứng nhận đầu tư cấp ngày: 15/04/2015
- Ngày bắt đầu hoạt động: 15/10/2015
- Tổng vốn đầu tư: 200.000.000 USD



# ONE\_STOP SYSTEM từ đúc phôi nguyên vật liệu dùng cho đúc ép nhôm đến gia công/lắp ráp phụ tùng cuối cùng

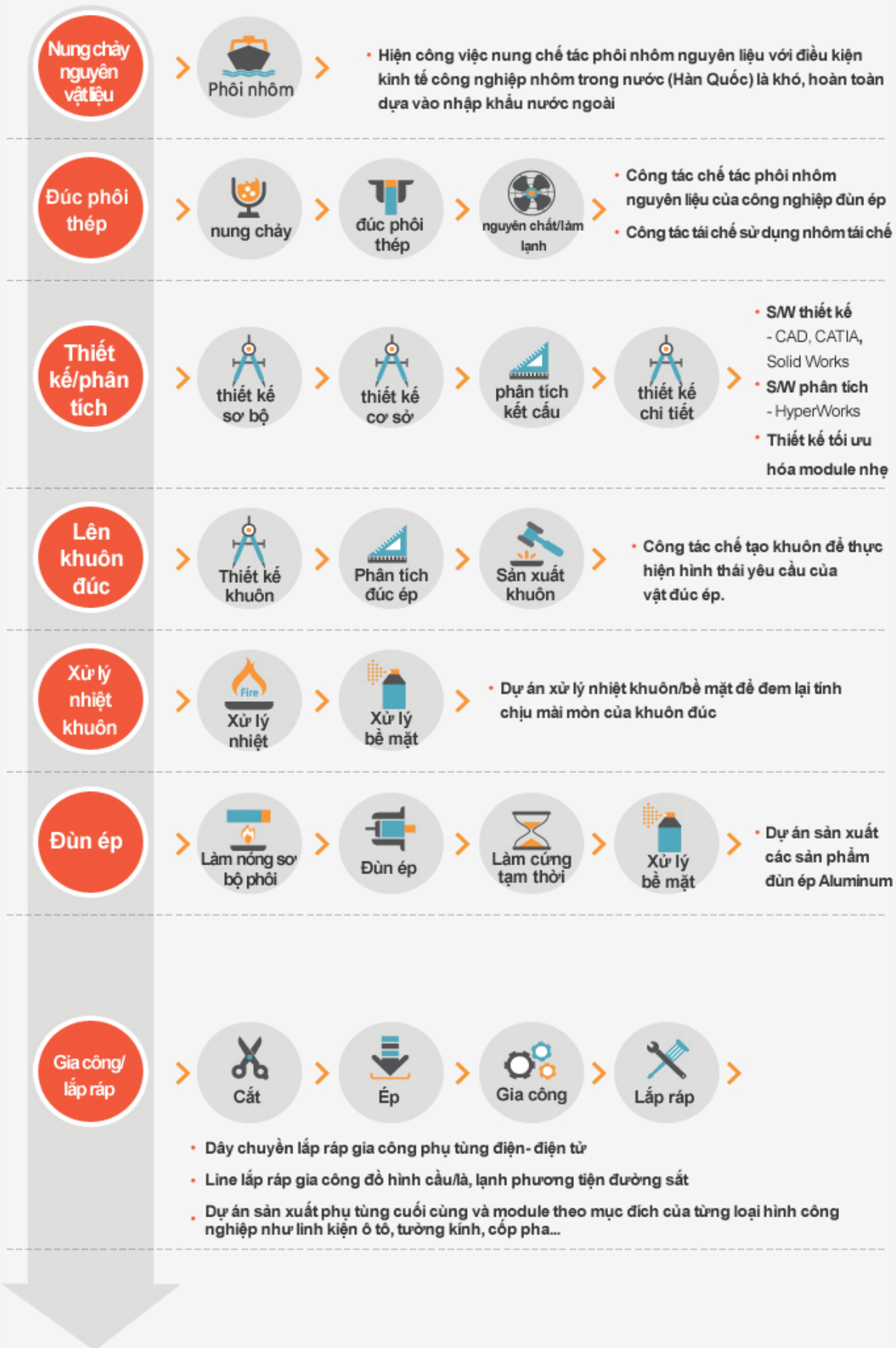



# GIỚI THIỆU TẬP ĐOÀN VÀ CÔNG TY

## III. Đạo đức kinh doanh:

- Tập đoàn ALUKO nhận thức rõ ràng rằng trách nhiệm xã hội, trách nhiệm pháp lý, và trách nhiệm về mặt đạo đức đều là nghĩa vụ cơ bản của doanh nghiệp, tập đoàn đang thực hiện tích cực hoạt động quản lý về mặt đạo đức nhằm hướng tới mục tiêu kinh doanh cùng có lợi với tất cả đối tác liên quan như quý khách hàng, cổ đông, xã hội...



# 01

### Triết lý quản lý:

Nhằm thích nghi hoạt động với môi trường doanh nghiệp không ngừng thay đổi, tập đoàn ALUKO đang phát triển đa dạng các hoạt động cải tiến về quản lý, quản lý chất lượng, quản lý tri thức và quản lý minh bạch.

# 02

### Quản lý chất lượng:

- Thỏa mãn nhu cầu đa dạng của khách hàng,
- Thiết lập hệ thống sản xuất và bán hàng theo định hướng của thị trường,
- Dẫn đầu trong các sản phẩm nhôm dân dụng và công nghiệp.

# 03

### Quản lý tri thức:

- Nâng cao năng lực chuyên môn thông qua việc đào tạo kỹ năng chuyên sâu,
- Chia sẻ công nghệ thông qua các chương trình đào tạo nội bộ, định kỳ.

# 04

### Quản lý minh bạch:

- Công khai các kết quả quản lý kinh doanh,
- Xây dựng hệ thống chia sẻ nhanh thông tin sản xuất kinh doanh.

# NĂNG LỰC SẢN XUẤT VÀ LĨNH VỰC KINH DOANH

Đúc: 84,000 tấn/năm  
Chế tạo khuôn đùn ép: 8,400 bộ/năm  
Đùn ép: 84,000 tấn/năm  
Sơn phủ bề mặt: 12,000 tấn/năm  
Anodizing: 10,000 tấn/năm  
Gia công: 15,000 tấn/năm  
Thiết kế và lắp đặt mặt dựng, cửa sổ, profile công nghiệp và ván khuôn nhôm (Al-form).



## LĨNH VỰC KIẾN TRÚC

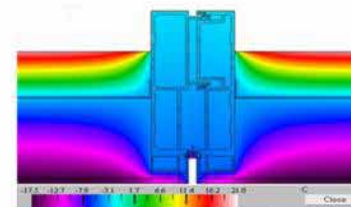
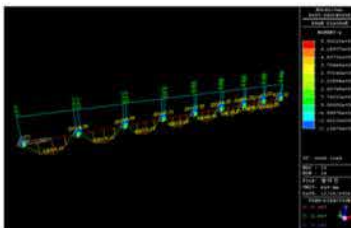
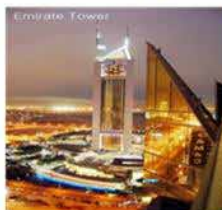
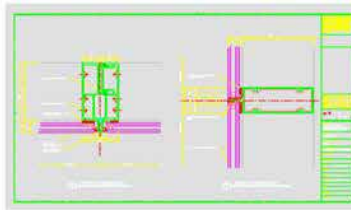





Công nghệ làm nên tương lai phồn vinh

# LĨNH VỰC KINH DOANH CHÍNH

## LĨNH VỰC CÔNG NGHIỆP

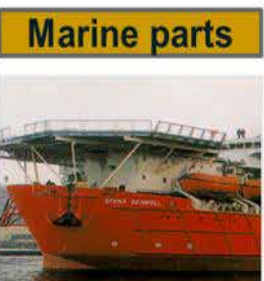
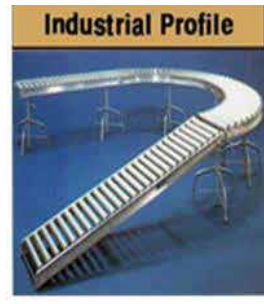
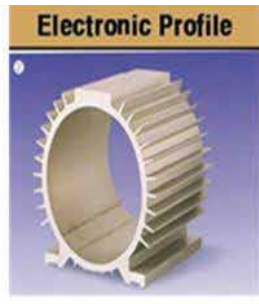
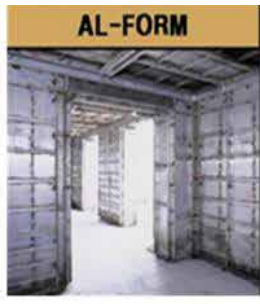
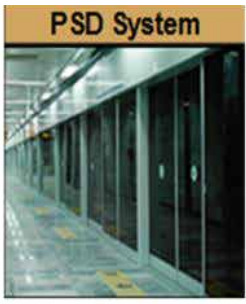
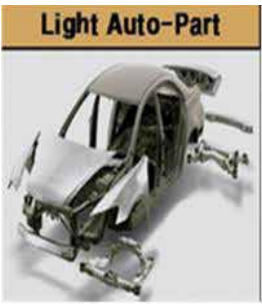



# DÂY CHUYỀN SẢN XUẤT

## I. Đúc billet:

Hyundai Aluminum Vina chuyên đúc và cung cấp các sản phẩm phôi nhôm chất lượng cao và đa chủng loại như: 6061, 6063, 7003,...



## II. Chế tạo khuôn và xử lý nhiệt:

- Công suất chế tạo khuôn 700 bộ/tháng
- Cung cấp thép công cụ
- Cung cấp dịch vụ xử lý bề mặt kim loại và xử lý nhiệt.

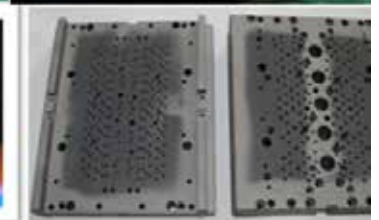
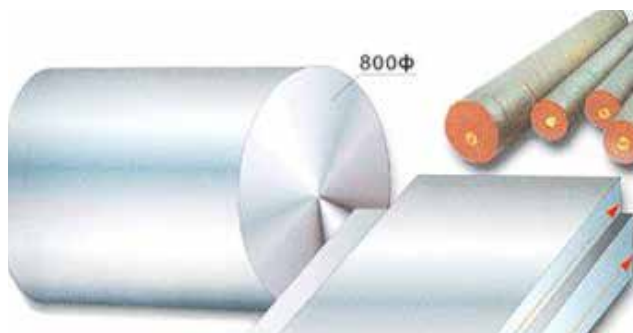



## III. Sơn phủ bề mặt:

- Sở hữu dây chuyền sơn đứng và sơn ngang đạt công suất 1,000 tấn/tháng
- Sơn PVDF và Acryl: 350 tấn
- Sơn bột tĩnh điện: 650 tấn
- Thỏa mãn tiêu chuẩn AAMA2603,2604,2605
- Bảo hành độ bền màu trên 20 năm



## IV. Đùn ép:

Sở hữu máy đùn ép công suất 8,000 tấn lớn nhất châu Á, tập đoàn chúng tôi có thể đùn ép sản phẩm tối đa 650mm.

Dây chuyền hiện có (10 máy đùn ép):

**12":1ea \* 11":1ea \* 8":3ea \* 7":4ea \* 6":1ea**



## V. Anodizing:

Sử dụng công nghệ hiện đại, đảm bảo chất lượng bề mặt. Đa dạng về chủng loại, màu sắc như: Mạ a nốt tự nhiên (trong), mạ màu đồng (khoảng màu đa dạng), mạ a nốt đen,...



## VI. Gia công, lắp ráp:

Dây chuyền gia công hiện đại dùng cho gia công, lắp ráp các sản phẩm xây dựng (cửa sổ, mặt dựng, ván khuôn nhôm,...) và các sản phẩm công nghiệp (TV, điện thoại, pin năng lượng mặt trời, thang nhôm,...)







## VII. Nghiên cứu và thiết kế:

Phát triển sản phẩm, công nghệ, quy trình và sản phẩm nhằm đáp ứng tốt nhất nhu cầu của người tiêu dùng. Nghiên cứu nâng cao công nghệ vật liệu, quy trình với tiêu chuẩn cao nhất bằng việc cách tân và không ngừng thử thách thông qua hợp tác công nghệ với các doanh nghiệp tiên tiến trong và ngoài nước.

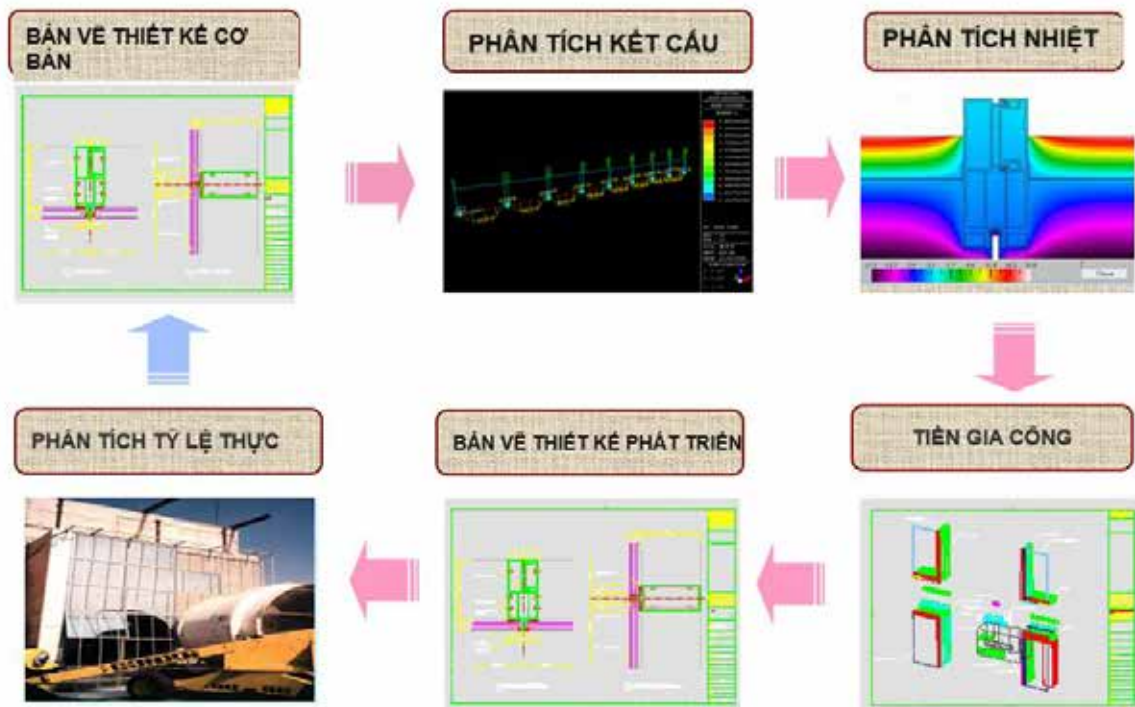

# CHỨNG CHỈ CHẤT LƯỢNG





## Tính chất cơ khí:

|         |    | Thử nghiệm độ cứng            |         |                               | Thử nghiệm độ kéo căng |                                    |                    |         |
|---------|----|-------------------------------|---------|-------------------------------|------------------------|------------------------------------|--------------------|---------|
|         |    | Độ dày vị trí thử nghiệm (mm) | HV (5)  | Độ dày vị trí thử nghiệm (mm) | Cường độ kéo           | Độ bền Kgf/mm (N/mm <sup>2</sup> ) | Tỉ lệ kéo căng (%) |         |
| A6063 S | T1 | Trên 0.8                      | Trên 58 | Dưới 12                       | Trên 12 (118)          | Trên 6.9 (59)                      | Trên 12            |         |
|         |    |                               |         | Quá 12<br>Dưới 25             | Trên 11 (108)          | Trên 5.5 (54)                      | Trên 12            |         |
|         | T5 |                               |         | Dưới 12                       | Trên 16 (157)          | Trên 11 (108)                      | Trên 8             |         |
|         |    |                               |         | Quá 12<br>Dưới 25             | Trên 15 (148)          | Trên 11 (108)                      | Trên 8             |         |
|         | T6 |                               |         | Dưới 3                        | Trên 21 (206)          | Trên 18 (117)                      | Trên 8             |         |
|         |    |                               |         | Quá 3<br>Dưới 25              | Trên 21 (206)          | Trên 18 (117)                      | Trên 10            |         |
| A6061 S | T4 |                               |         |                               | Trên 18 (177)          | Trên 11 (108)                      | Trên 16            |         |
|         | T6 |                               |         |                               | Dưới 6                 | Trên 27 (265)                      | Trên 25 (245)      | Trên 8  |
|         |    |                               |         |                               | Quá 6                  | Dưới 27 (265)                      | Dưới 25 (245)      | Trên 10 |

## Thành phần hóa học:

| Số hợp kim | Kiểm tra cường độ |        |           |        |          |           | Kiểm tra độ kéo căng |              |        |          |        |    |
|------------|-------------------|--------|-----------|--------|----------|-----------|----------------------|--------------|--------|----------|--------|----|
|            | Si                | Fe     | Cu        | Mn     | Mg       | Cr        | Zn                   | Zr, Zr+ T, V | Ti     | Khác     |        | Al |
|            |                   |        |           |        |          |           |                      |              |        | 0.45-0.9 | Tổng   |    |
| 6063       | 0.20-0.6          | <=0.35 | <=0.10    | <=0.10 | 0.45-0.9 | <=0.10    | <=0.10               | -            | <=0.10 | <=0.05   | <=0.05 |    |
| 6061       | 0.40-0.8          | <=0.7  | 0.15-0.40 | <=0.15 | 0.80-1.2 | 0.40-0.35 | <=0.10               | -            | <=0.10 | <=0.05   | <=0.05 |    |

## Tính chất lý & hóa / Physical & Chemical Properties:

| Danh mục kiểm tra / Test Items                      | Tiêu chuẩn Aama 2605 / Aama 2605 spec (98)  | Kết quả / Result                             | Ghi chú / Remarks  |
|---|---|--|--|
| Độ bóng<br>Gloss -60°                               | Low: Max 19, Medium: 20-19<br>High: Min 80  | 25-35  | ASTM D523<br>(60 Degree gloss meter)                                       |
| Độ cứng<br>Dry Film Hardness                        | F Min   | H  | ASTM D3363<br>(Aegle Turquoise Pencil)                                     |
| Tính bám dính<br>Adhesion                           | No Removal of Film (100/100)  | 100/100                                      | 1mm Cross Cut Wet & Dry  |
| Tính bám dính ở t° sôi<br>Boiling Adhesion          | No Removal of Film (100/100)  | 100/100                                      | 1mm Cross Cut<br>99~100°C x 20min  |
| Chống va đập<br>Impact Resistance                   | No Removal of Film  | No Removal of Film                           | 16mm Diameter, Gardner<br>Impact Tester                                    |
| Chống mài mòn<br>Adhesion Resistance                | Abrasion Coefficient Value (V/T)<br>40 Min  | 65   | ASTM D968  |
| Chống axit<br>Acid Resistance                       | No Blistering<br>No Visual Change   | No Blistering<br>No Visual Change            | 15 Mins(18~27°C) Spot Test<br>(10% Muriatic Acid)                          |
| Chống chịu vôi vữa<br>Mortar Test                   | No Loss of Film Adhesion<br>No Visual Change  | No Loss of Film Adhesion<br>No Visual Change | 24Hrs Pat Test   |
| Chống axit Ni tơ ric<br>Nitric Acid Resistance      | Color Change 5ΔE(Hunter) Max,<br>...ASTM D2244  | 3ΔE  | 70% Nitric Acid 30 Mins  |
| Chống chịu chất tẩy rửa<br>Detergent Resistance     | No Blistering, No Visual Change<br>...ASTM D3359  | No Blistering<br>No Visual Change            | Glass Cleaner Dropping   |
| Chống bám bẩn<br>Window cleaner Resistance          | No Blistering, No Visual Change   | No Blistering<br>No Visual Change            | 3% Detergent<br>38°C x 72 Hrs  |
| Tính chống ẩm<br>Humidity Resistance                | "Few: Blister (No.8) Max,<br>...ASTM D714   | No Blistering                                | ASTM D2247<br>(100% RH, 100°F, 4000 Hrs)                                   |
| Chống ăn mòn với nước biển<br>Salt Spray Resistance | 1/32" Max, Under Cutting<br>...ASTM D1654   | 1/32"  | ASTM B117<br>(5% Salt, 100°F, 4000 Hrs)                                    |
| Chống chịu ngoại cảnh<br>Weathering Color Retention | Color Change 5ΔE(Hunter) Max,...ASTM D2244<br>Gloss Retention (60°)50% Min,...ASTM D523 | 3ΔE<br>80%                                   | South Florida Exposure<br>10 Years<br>45°, Florida<br>(Latitude 27° North) |
| Chống già hóa<br>Chalk Resistance                   | Chalking rating No.8 (Colors)<br>and No.6(white) Max,...ASTM D659                       | Colors: No.8<br>White: No.6                  |  |
| Chống ăn mòn<br>Resistance to Erosion               | 10% Loss Max  | 5%   |  |

## Phôi nhôm đùn ép:

| Mô tả                          | Điều kiện bảo đảm |
|--------------------------------|-------------------|
| Bề mặt                         | Đặt theo mẫu      |
| Độ vồng                        | Max. 1mm/M        |
| Đường kính                     | Max. +1, -2mm     |
| Chiều dài cắt                  | Max. +0, -5mm     |
| Góc cắt                        | ≤ 0.5°            |
| Nứt vỡ                         | Không             |
| Cỡ hạt                         | ≤ 200µm           |
| Nét đứt gãy đường biên các hạt | ≤ 100µm           |
| Oxide và các khí khác          | ≤ 100µm           |
| Khí H <sub>2</sub>             | 0.2cc/100g        |

## Sơn:

| Phân loại | Hệ thống sơn | Quy trình   | Độ dày lớp sơn |
|-----------|--------------|---|----------------|
| PVDF      | 2 lớp        | Tiền xử lý → Lớp lót → Lớp màu → Sấy khô            | 30µm           |
|           | 3 lớp        | Tiền xử lý → Lớp lót → Lớp màu → Lớp bóng → Sấy khô | 40µm           |
| ACRYL     | 2 lớp        | Tiền xử lý → Lớp lót → Lớp màu → Sấy khô            | 30µm           |
| POWDER    | 2 lớp        | Tiền xử lý → Sơn bột tĩnh điện → Sấy khô            | 60µm           |





VĂN HÓA KINH DOANH HƯỚNG TỚI NỀN CÔNG NGHIỆP  
THÂN THIỆN VỚI MÔI TRƯỜNG VÀ TƯƠNG LAI NHÂN LOẠI

# QUY ĐỊNH MÃ SẢN PHẨM

## 1. Sản phẩm dân dụng:

Ví dụ: (HD) 080 SL 1014, Thanh trượt trên hệ cửa trượt 80 MM (khe lắp kính 10MM)  
 (HD) 100 DR 1008, Thanh giữa cửa đi hệ 100MM (khe lắp kính 10MM)

| Thương hiệu<br>(Không biểu thị) | 3 chữ số đầu | 2 chữ số giữa | 4 chữ số cuối | Tổng 9 chữ số |
|---------------------------------|--------------|---------------|---------------|---------------|
| HD                              | ○ ○ ○        | ○ ○           | ○ ○ ○ ○       |               |

- \* Ba chữ số đầu: Kích thước hệ cửa, ví dụ: 80MM - 080 ; 110MM - 110
- \* Hai chữ số giữa: Chủng loại sản phẩm

| TT | Tên viết tắt | Tên sản phẩm                            | TT | Tên viết tắt | Tên sản phẩm                       | TT | Tên viết tắt | Tên sản phẩm                       |
|----|--------------|---|----|--------------|------------------------------------|----|--------------|------------------------------------|
| 1  | SL           | SLiding<br>(Cửa trượt)                  | 7  | PS           | Pipe Squar<br>(Ống vuông)          | 13 | SP           | SPandral<br>(Biển hộp & Vách ngăn) |
| 2  | FS           | Fix & Sliding<br>(Cửa trượt và cố định) | 8  | PR           | Pipe Round<br>(Ống tròn)           | 14 | ST           | ShuTter<br>(Nan cửa cuốn)          |
| 3  | FX           | FiX<br>(Cố định)                        | 9  | AG           | AnGle<br>(Góc, chi tiết dạng V)    | 15 | LV           | LouVer<br>(Cửa chớp chuyển động)   |
| 4  | PJ           | ProJect<br>(Cửa mở lật)                 | 10 | CN           | ChaNel<br>(Biên cạnh vuông)        | 16 | CW           | Curtain Wall<br>(Tường kính)       |
| 5  | CM           | CaseMent<br>(Cửa mở quay)               | 11 | CP           | Coner Piece<br>(Chi tiết ghép góc) | 17 | Sc           | Screen<br>(Lưới chắn côn trùng)    |
| 6  | DR           | DooR<br>(Cửa đi)                        | 12 | GA           | GAllary<br>(Cửa chớp cố định)      |    |              |                                    |

\* Bốn chữ số cuối: ○ ○ ○ ○ ← Vị trí profile  
 Profile thứ phát đánh số thứ tự từ 1 đến 9  
 Khe lắp kính 10mm -> 10, 12mm -> 12

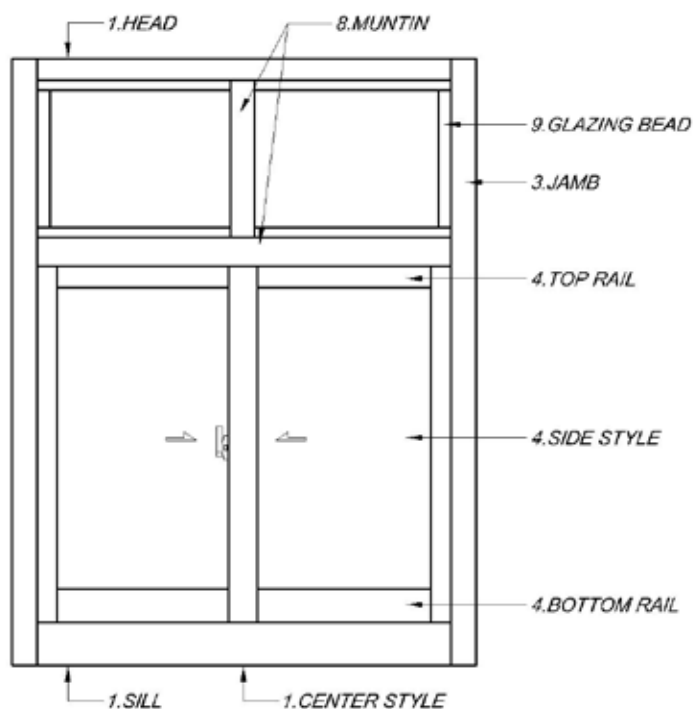

| TT | Vị Trí            |
|----|-------------------|
| 1  | Thanh trên        |
| 2  | Thanh dưới        |
| 3  | Thanh bên         |
| 4  | Đường chạy trên   |
| 5  | Đường chạy dưới   |
| 6  | Thanh trượt giữa  |
| 7  | Thanh trượt cạnh  |
| 8  | Thanh chia khung  |
| 9  | Chi tiết cài kính |



## 2. Sản phẩm công nghiệp

Ví dụ: (HD) HMS HS 5001, Heat sink (Lá tản nhiệt)  
(HD) HMS SC 5002, Speaker case (Vỏ loa)

| Thương hiệu<br>(Không biểu thị) | 3 chữ số đầu | 2 chữ số giữa | 4 chữ số cuối | Tổng 9 chữ số |
|---------------------------------|--------------|---------------|---------------|---------------|
| HD                              | ○ ○ ○        | ○ ○           | ○ ○ ○ ○       |               |

\* Ba chữ số đầu: Cố định bằng HMS (ký hiệu vật liệu Hyundai Vina dùng trong ngành công nghiệp)

\* Hai chữ số giữa: Chủng loại sản phẩm

| TT | Tên viết tắt | Tên sản phẩm                |
|----|--------------|-----------------------------|
| 1  | HS           | Heat Sink<br>(Lá tản nhiệt) |
| 2  | MD           | MolDing<br>(Khuôn mẫu)      |
| 3  | SC           | Speaker Case<br>(Vỏ loa)    |
| 4  | LC           | Light Case<br>(Hộp đèn)     |

\* Bốn chữ số cuối: Đánh số theo thứ tự từ 5000



# GIỚI THIỆU SẢN PHẨM





# ĐÁP ỨNG TỐI ĐA NHU CẦU HOÀN THIỆN NGOẠI THẤT CHO NGÔI NHÀ BẠN

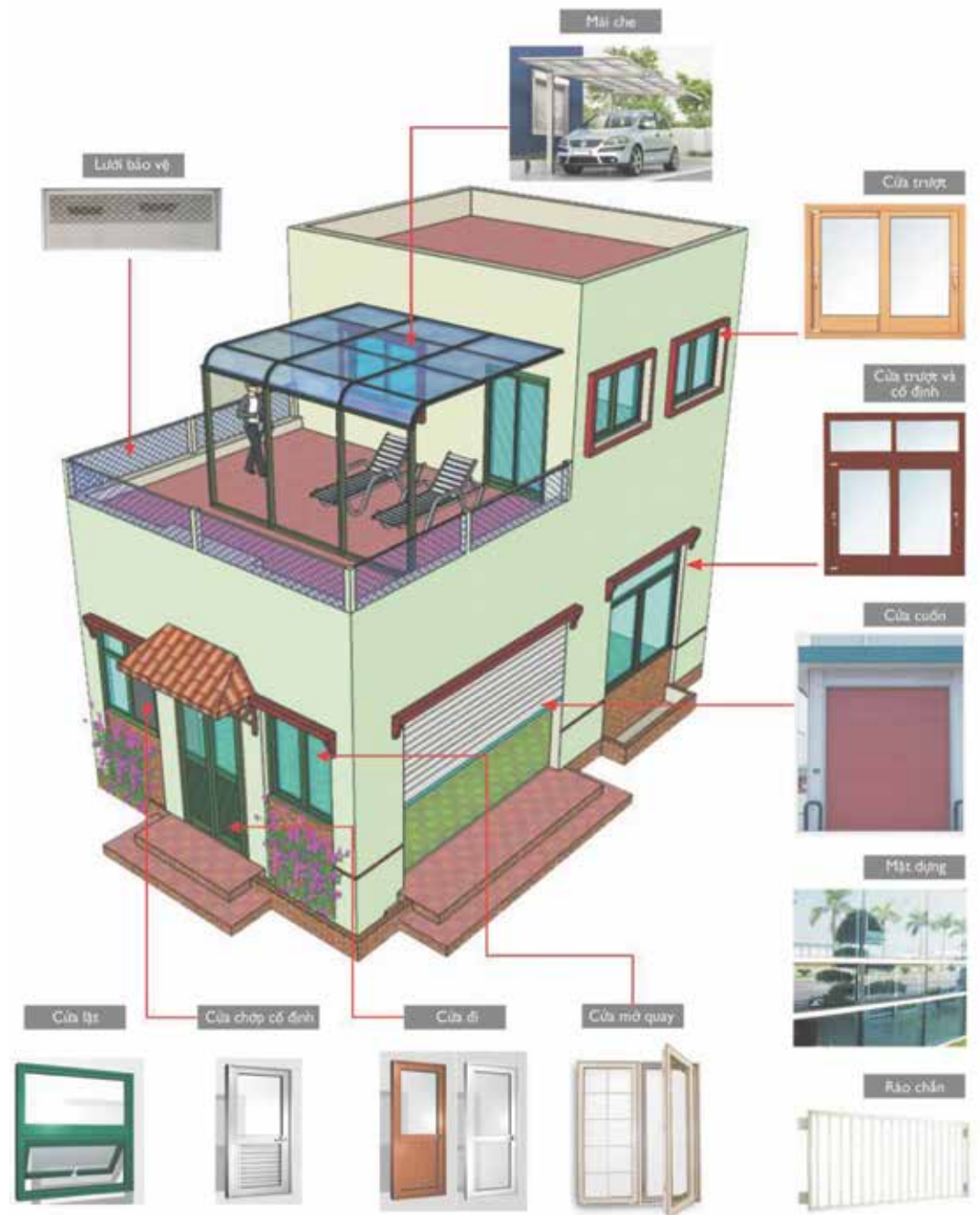

## Cửa mở lật và mở quay

1. Mở lật vào trong 1 góc 10° đến 15°
2. Mở quay giúp trao đổi khí tài tối đa, thuận tiện khi vệ sinh
3. Tùy chọn tông màu riêng biệt cho mặt trong và mặt ngoài, dễ phối hợp với tông màu ngoài nhà.
4. Cầu cách nhiệt polyamide đem lại hiệu cách nhiệt tối đa, tiết kiệm điện
5. Tạo nên sự sang trọng và khỏe khoắn với tay nắm cửa đa dạng về màu sắc cùng khả năng chịu lực đến 80kg

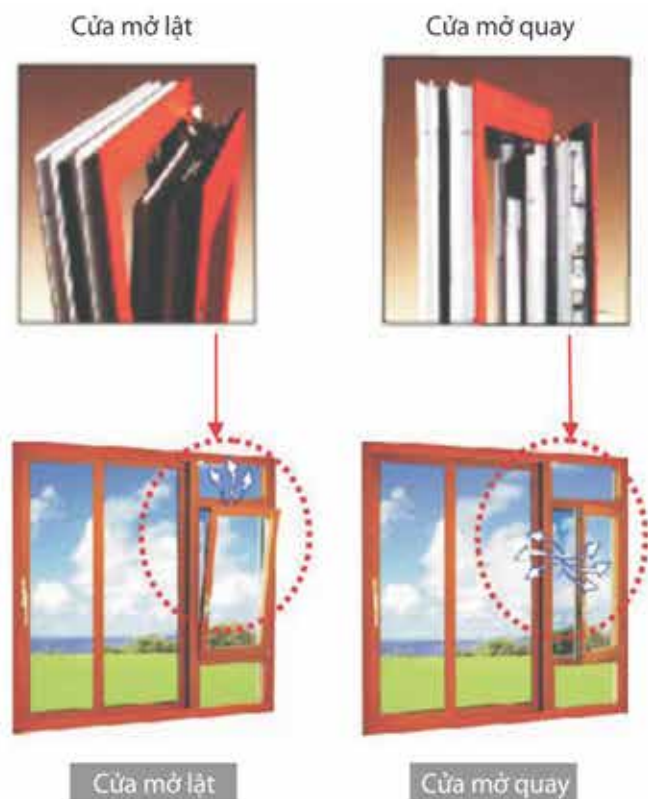

## Cửa nâng trượt

1. Mở dễ dàng bằng cách xoay tay nắm 180° giúp nâng cánh trượt lên sau đó trượt ngang như bình thường
2. Ở vị trí đóng, cánh cửa hạ xuống, ép chặt với khung tạo độ kín, khít tối đa nhất
3. Cầu cách nhiệt polyamide đem lại hiệu quả cách nhiệt tối đa, tiết kiệm điện
4. An toàn với khóa chốt 4 điểm
5. Tùy chọn tông màu riêng biệt cho mặt trong và mặt ngoài, dễ phối hợp với tông màu ngoài nhà
6. Kích thước tối đa: 2400 (rộng) x 2600 (cao), trọng lực lên tới 200kg

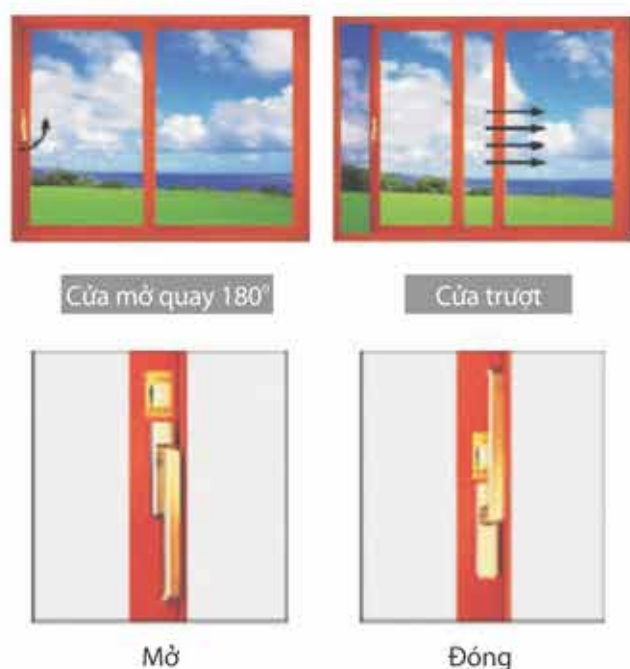



## I. Ép vân:

1. Tạo màu đa dạng
2. Có thể gia công sau khi ép vân trang trí
3. Tạo bề mặt nổi bật với màu hoa văn phù hợp
4. Có thể sử dụng vật liệu hoàn thiện ngoài trời với khả năng chịu ô nhiễm hóa chất

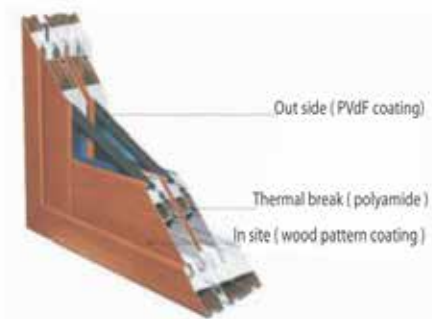

Aluminum System Windows

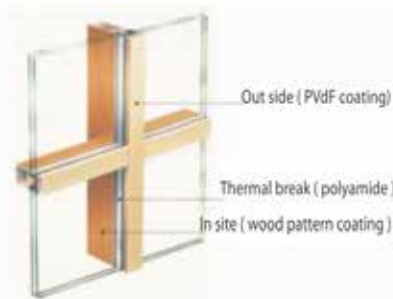

Aluminum Curtain Walls



Hoàn thiện nội thất

## II. Gia công lắp ráp:

### Quy trình gia công



### Quy trình lắp ráp



# AL - FORM

\* Cốp pha xây dựng bằng nhôm, được gia công tiêu chuẩn tại nhà máy. Đảm bảo đạt được kích thước chuẩn xác và bề mặt phẳng mịn cho toa nhà.

\* Thi công lắp đặt đơn giản và tiết kiệm thời gian.



## Biên Dạng Thanh Công Nghiệp

\* Đáp ứng mọi nhu cầu về số lượng cũng như kích cỡ, biến dạng (bao gồm cả gia công)

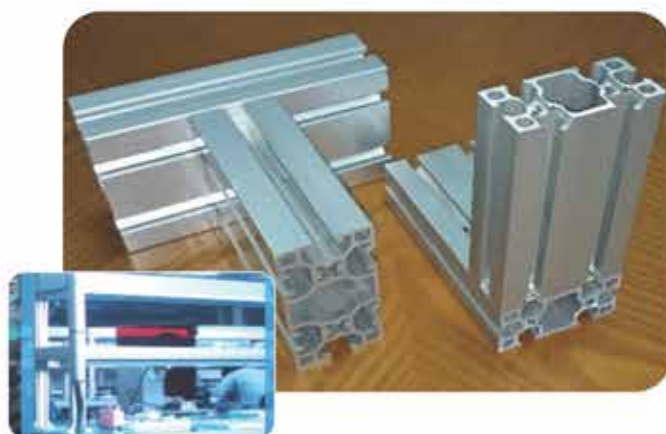

## Thang Nhôm

\* Đa dạng kích cỡ và chủng loại

\* Gia công và lắp đặt trên dây chuyền công nghệ hiện đại của Hàn Quốc, đảm bảo độ bền và tính an toàn cho người sử dụng







- \* Đối tác chính: Samsung Electronic, Panasonic, Sharp, ...
- \* Áp dụng công nghệ hàn nhôm FSW đầu tiên trên thế giới
- \* Tiêu chuẩn chất lượng kỹ thuật nghiêm ngặt, đồng bộ



## Khung Viên Đèn Led, Đế Tản Nhiệt

- \* Mọi công đoạn từ đúc ép, gia công, xi mạ đều thực hiện tại nhà máy đảm bảo quy trình giám sát chất lượng nghiêm ngặt.

## Khung Modul Năng Lượng Mặt Trời

- \* Lắp đặt linh hoạt các modul quang năng
- \* Đối tác: Symphony Energy, Seoul Marine, Hyundai Heavy Industries, Getwatt, S-Energy...



# CHẾ TẠO KHUÔN VÀ XỬ LÝ NHIỆT

Cung cấp các giải pháp tổng thể về khuôn đùn ép, xử lý bề mặt kim loại và xử lý nhiệt.



## CUNG CẤP THÉP CÔNG CỤ:

- Gia công vật liệu, xử lý nhiệt chân không, thấm ni tơ.
- Chế tạo khuôn đùn ép, gia công sửa chữa khuôn đột dập.
- Xử lý nhiệt (SKD61, SKD11, thép công cụ, JIC-đồ gá các loại

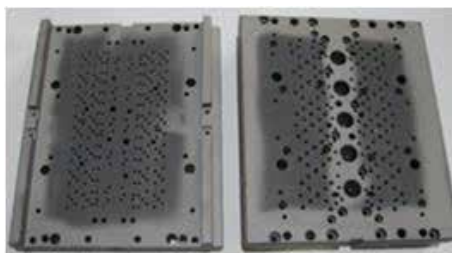
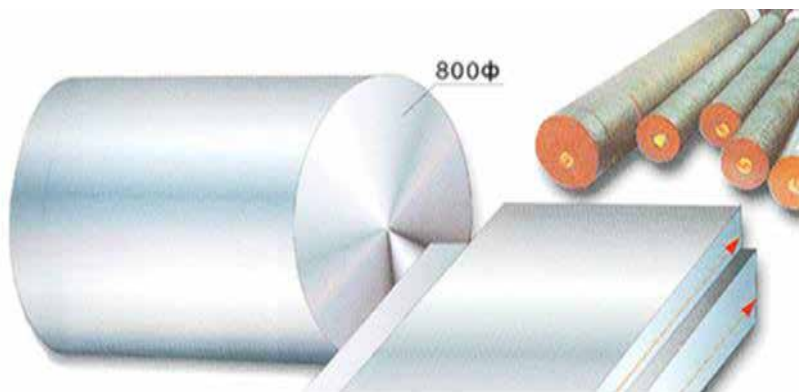



# SẢN PHẨM





## Đặc tính:

- Kết hợp phong cách hiện đại với nét đẹp cổ kính, mang đến sự đa dạng về kiểu dáng đem lại lựa chọn hoàn hảo trong kiến trúc xây dựng từ gia đình đến công sở.
- Lắp ghép đơn giản, nhanh gọn trong thi công giảm thiểu tối đa thời gian và chi phí cho Khách hàng.
- Màu sắc đa dạng (Sơn tĩnh điện, PVDF, vân gỗ, Anodized...), có thể đáp ứng những yêu cầu khắt khe nhất của từng hạng mục công trình

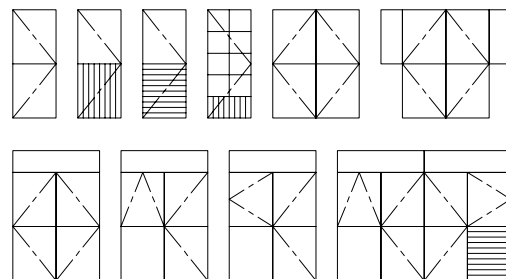

## Phụ kiện:



HANDLE



HINGE



WP 65-55



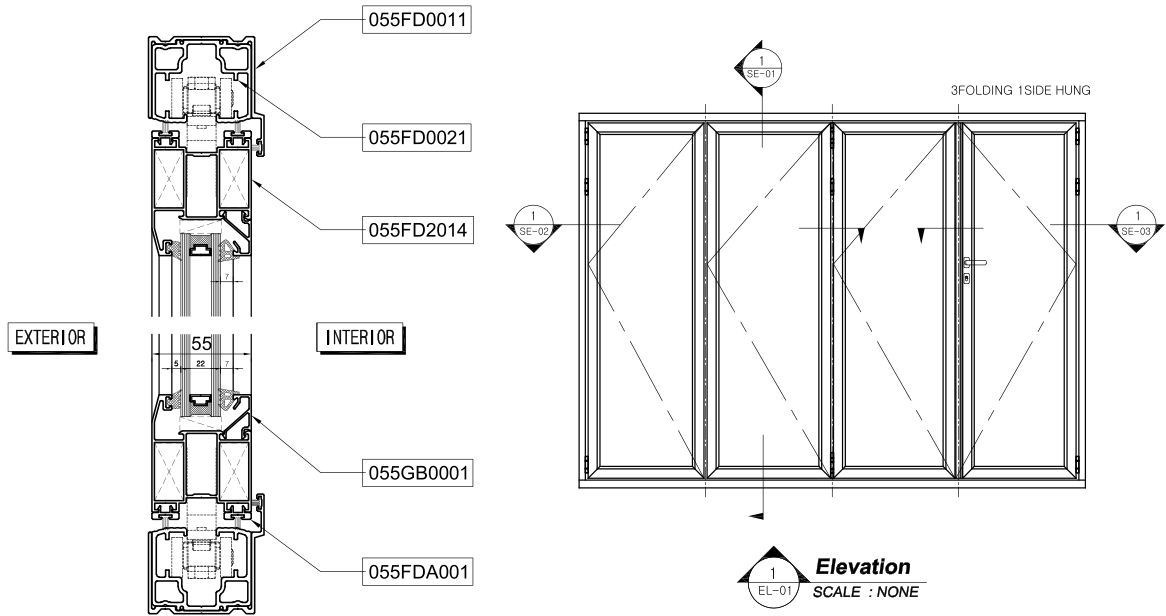

**Vertical Section Detail**  
SCALE : NONE

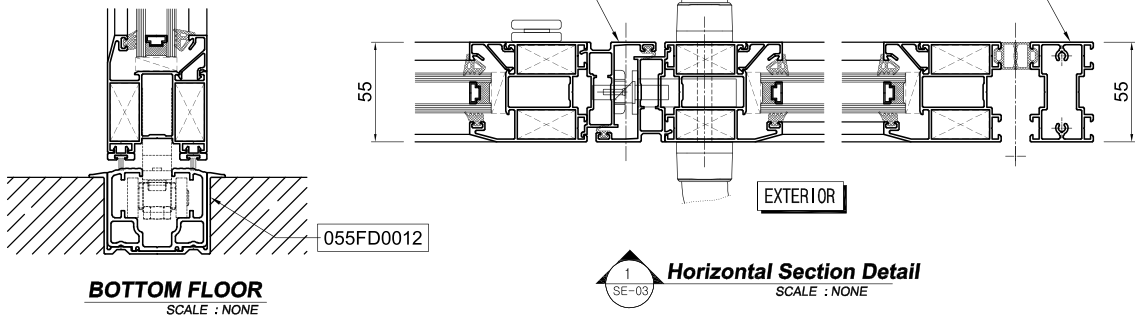

**BOTTOM FLOOR**  
SCALE : NONE

**Horizontal Section Detail**  
SCALE : NONE

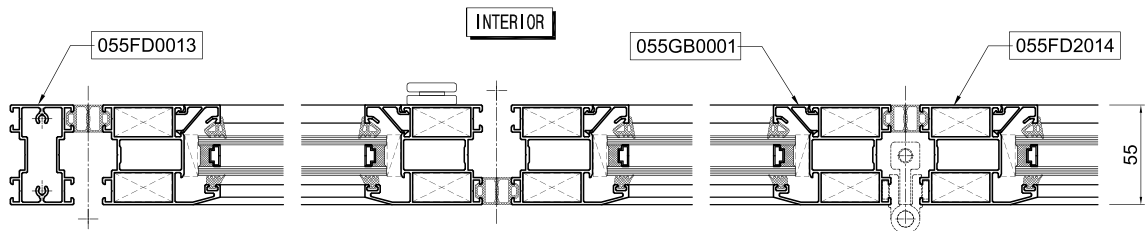

**EXTERIOR**

**Horizontal Section Detail**  
SCALE : NONE

### Đặc tính:

- Kết hợp phong cách hiện đại với sự đa dạng về kiểu dáng và cách phối trí đem lại lựa chọn hoàn hảo trong kiến trúc xây dựng từ gia đình đến công sở.
- Phù hợp những vị trí cần nhiều không gian mở ( Ban công biệt thự, cửa hàng,...)

### Mặt bằng:

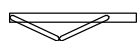

2 cánh xếp trượt



2 cánh xếp trượt & 1 cánh quay



3 cánh xếp trượt

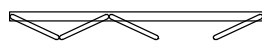

3 cánh xếp trượt & 1 cánh quay

### Phụ kiện:



# CỬA XÉP TRƯỢT HỆ 55

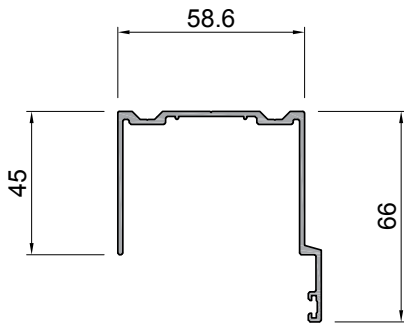

**055FD0011**  
THK. 1.6 mm - 0.845 Kg/m

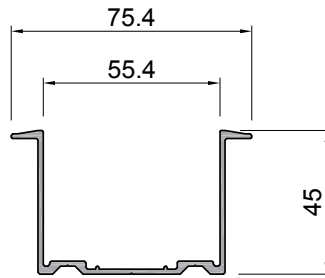

**055FD0012**  
THK. 1.6 mm - 0.790 Kg/m

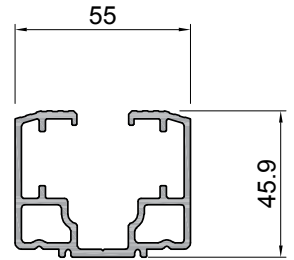

**055FD0021**  
THK. 2.0 mm - 1.426 Kg/m

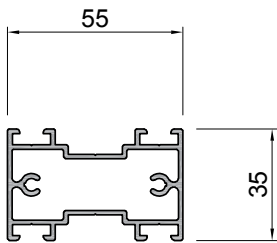

**055FD0013**  
THK. 1.4 mm - 1.009 Kg/m

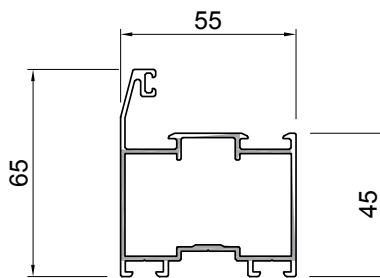

**055FD2014**  
THK. 1.4 mm - 1.084 Kg/m

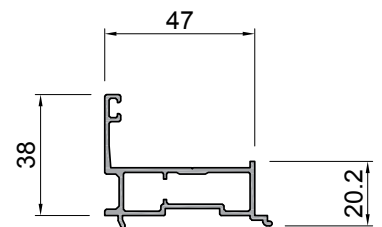

**055FD0016**  
THK. 1.4 mm - 0.685 Kg/m

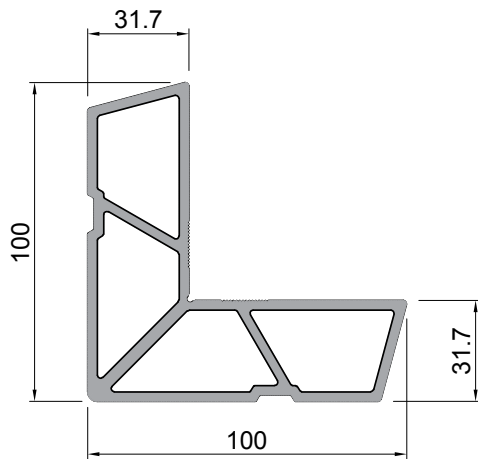

**100CP0031**  
THK. 3.0 mm - 3.900 Kg/m

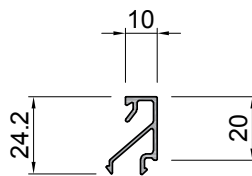

**055GB0001**  
THK. 1.2 mm - 0.218 Kg/m

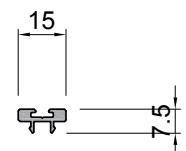

**055FDA001**  
THK. 1.3 mm - 0.135 Kg/m





# CỬA ĐI MỞ QUAY HỆ 65

Cửa mở quay ra ngoài

Công nghệ làm nên tương lai phần vịnh

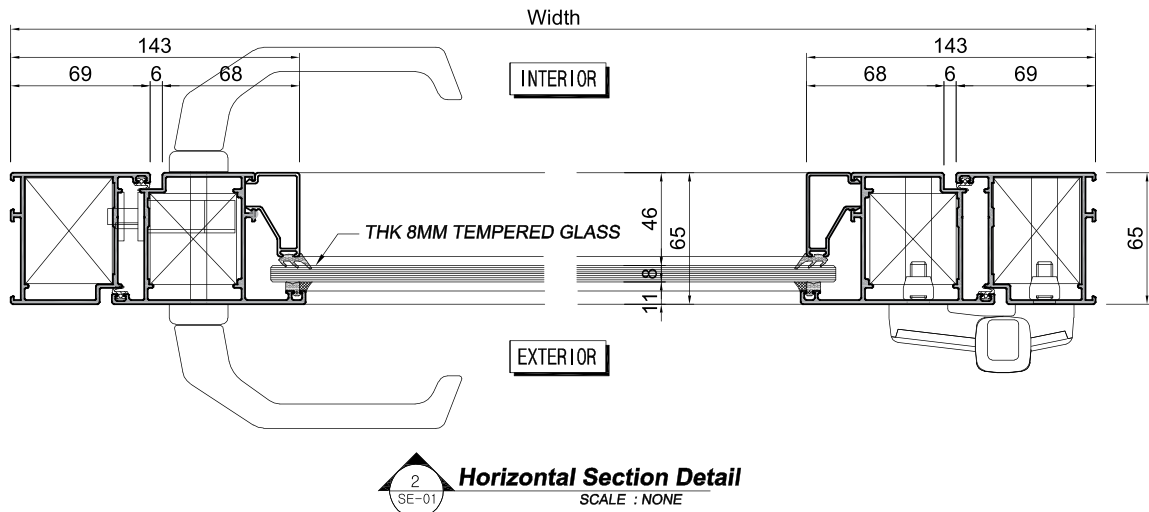
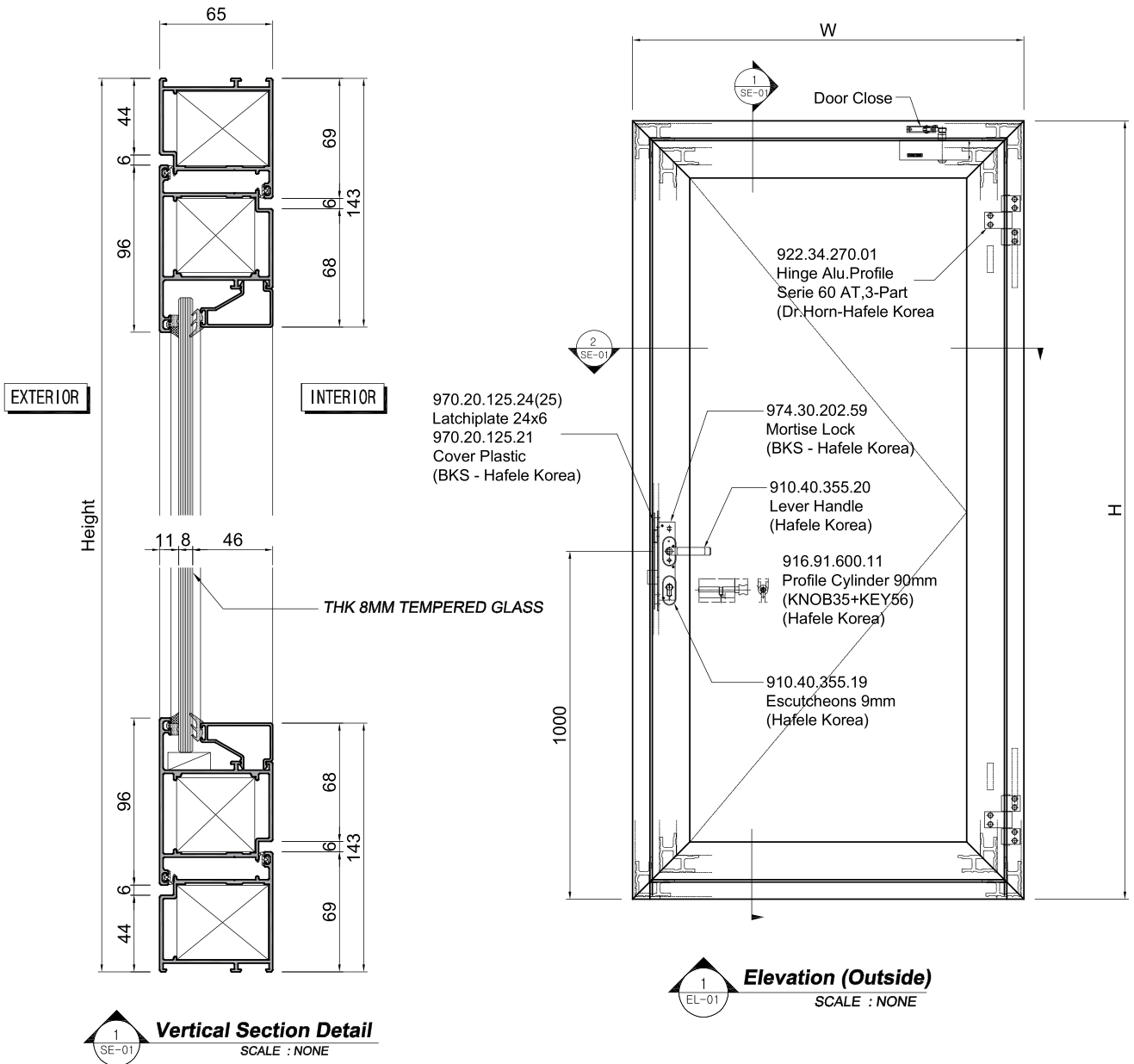



# CỬA ĐI MỞ QUAY HỆ 65

Cửa mở quay hai chiều

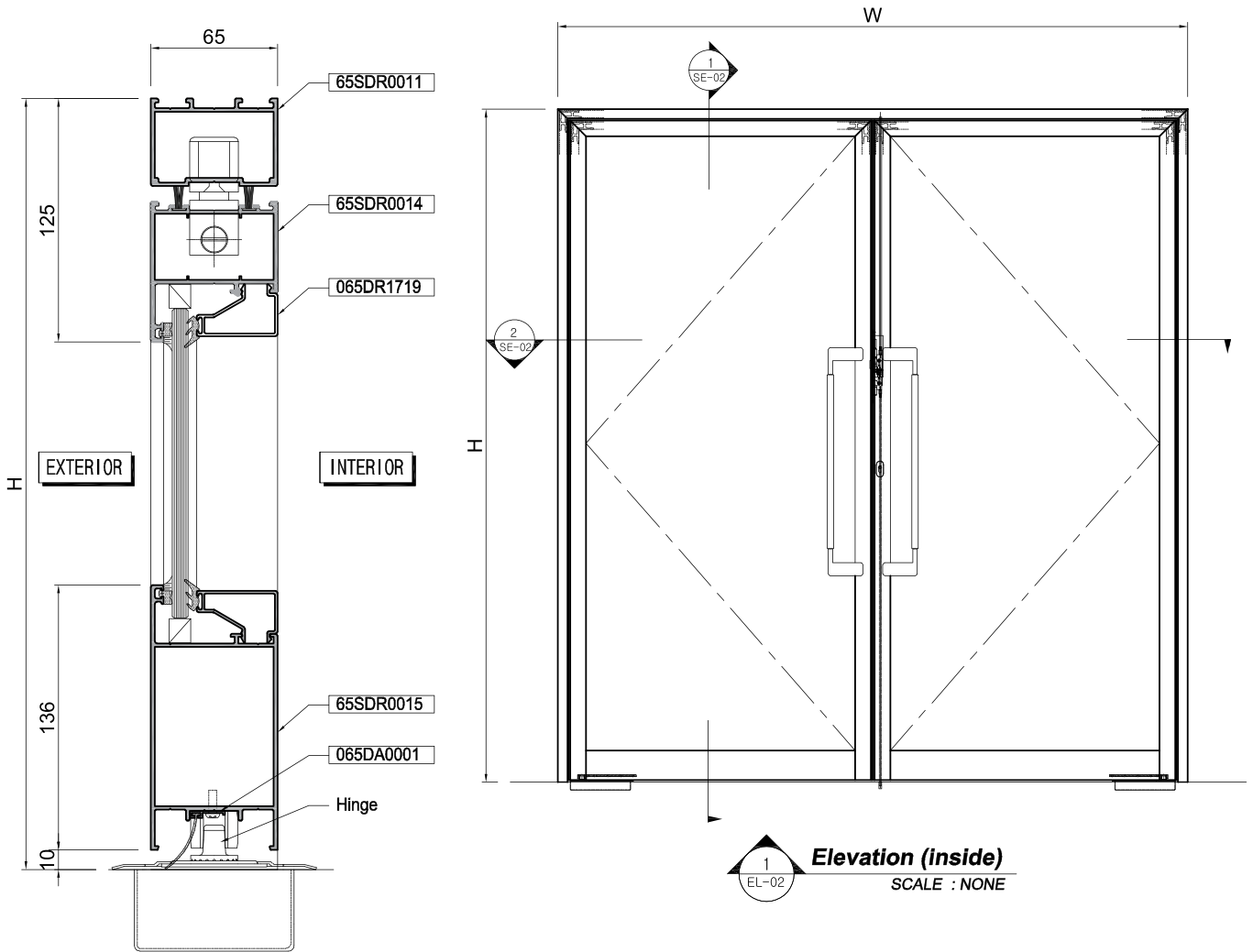

**1 Vertical Section Detail**  
SCALE : NONE

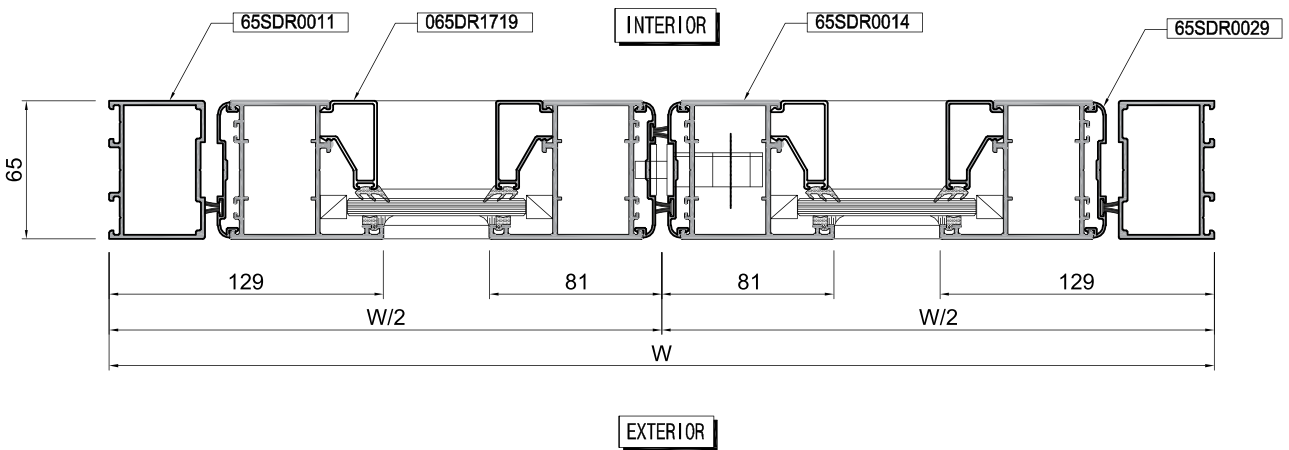

**2 Horizontal Section Detail**  
SCALE : NONE



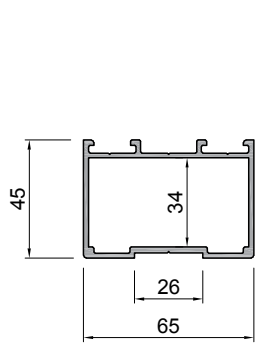

**65SDR0011**  
THK. 1.8mm - 1.249 Kg/m

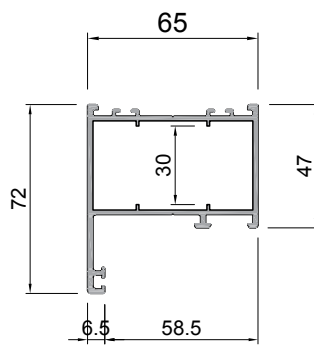

**65SDR0014**  
THK. 1.8mm - 1.428 Kg/m

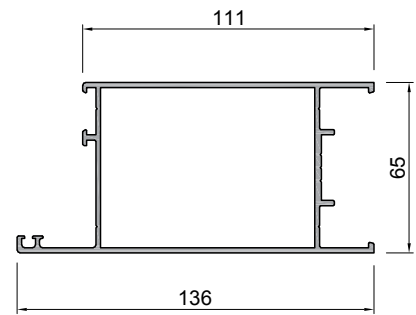

**65SDR0015**  
THK. 2.0mm - 2.158 Kg/m

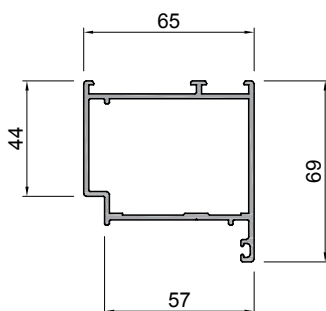

**065DR0011**  
THK. 1.8mm - 1.394 Kg/m

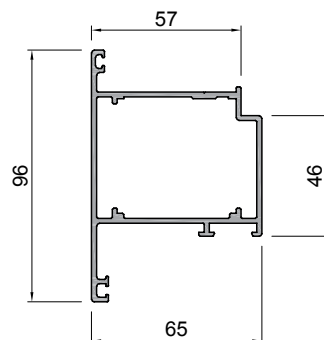

**065DR0014**  
THK. 1.8mm - 1.65 Kg/m

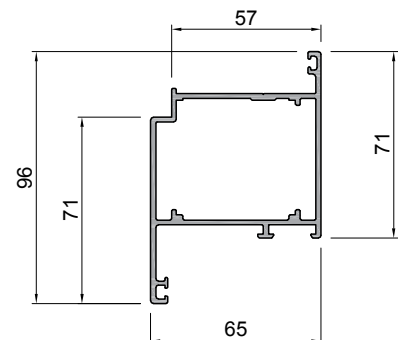

**065DR0017**  
THK. 1.8mm - 1.649 Kg/m

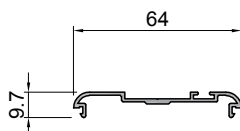

**65SDR0029**  
THK. 1.2mm - 0.333 Kg/m

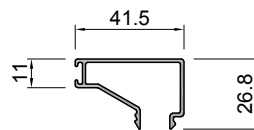

**065DR1719**  
THK. 1.35mm - 0.422 Kg/m

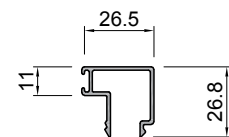

**065DR3119**  
THK. 1.35mm - 0.344 Kg/m

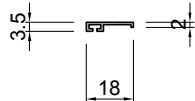

**065DA0001**  
THK. 1.0mm - 0.073 Kg/m

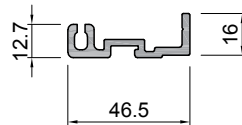

**065BR0001**  
THK. 3.0mm - 0.684 Kg/m

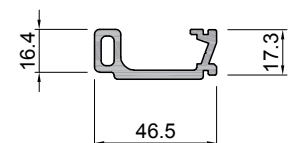

**065BR0002**  
THK. 2.5mm - 0.848 Kg/m

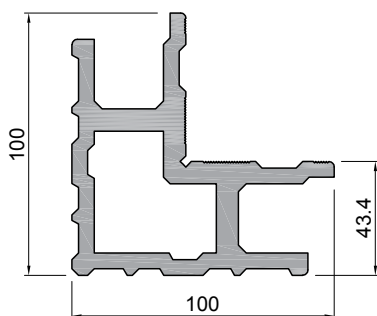

**100CP0011**  
THK. 6.0mm - 6.744 Kg/m

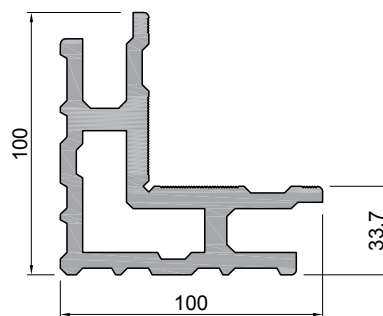

**100CP0033**  
THK. 6.0mm - 6.728 Kg/m

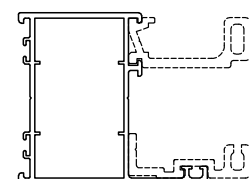

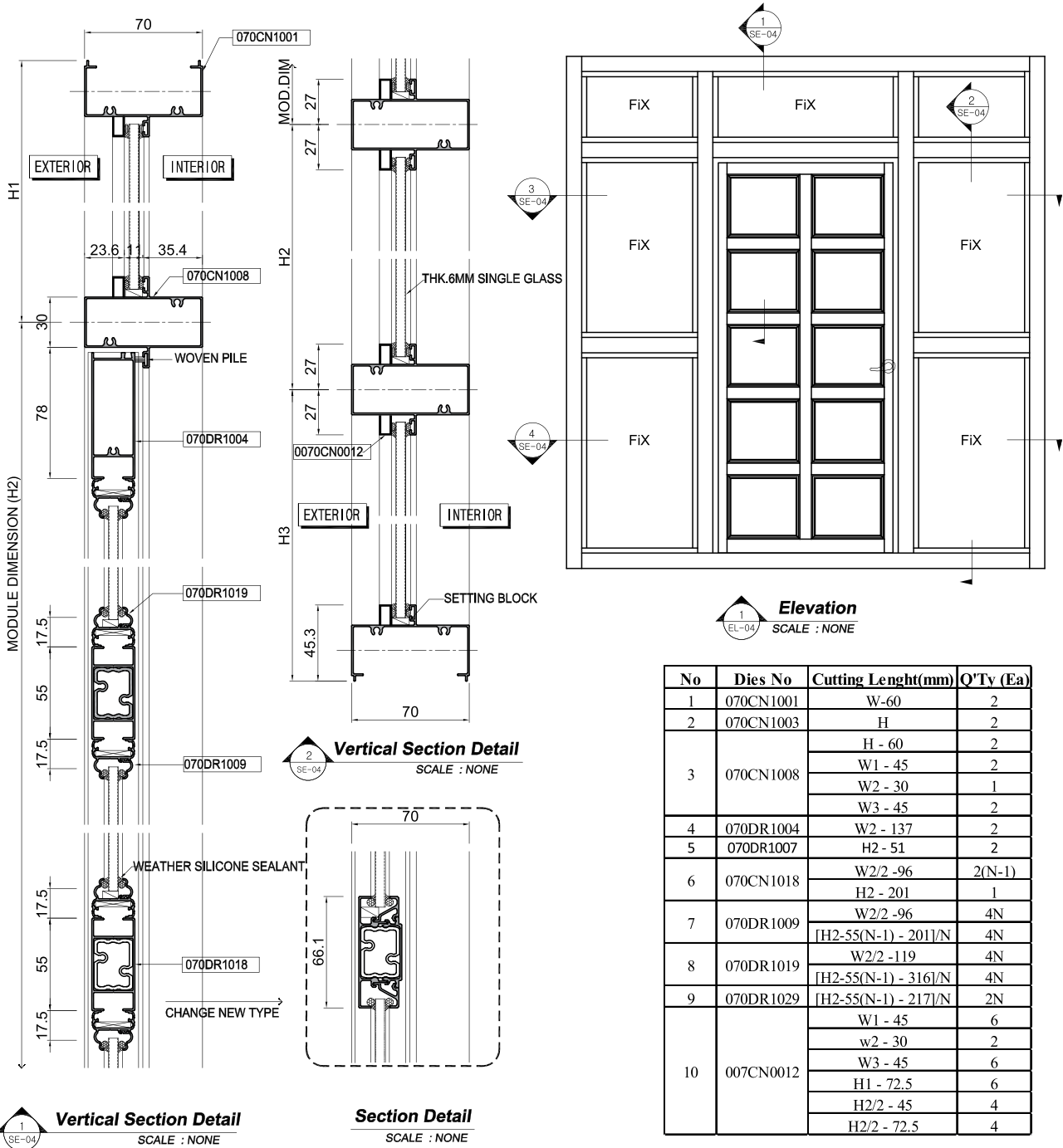

N là số hàng chia kính

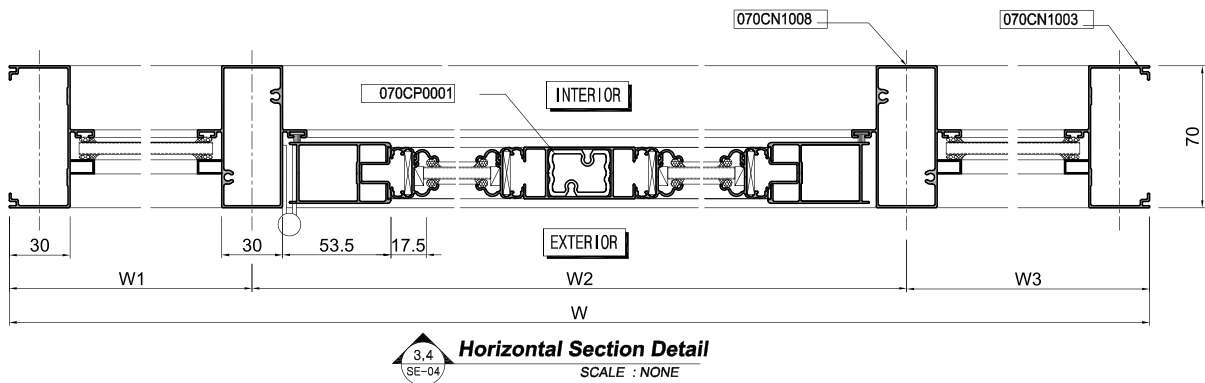

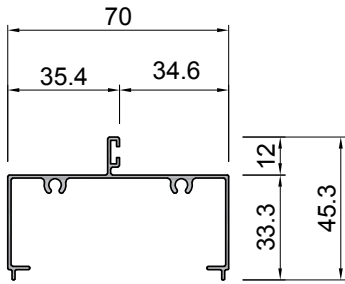

**070CN1001**  
THK. 1.0mm - 0.549 Kg/m

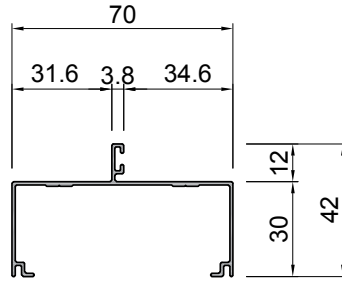

**070CN1003**  
THK. 1.0mm - 0.474 Kg/m

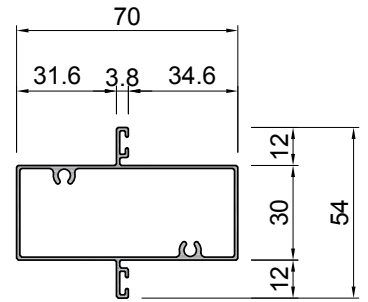

**070CN1008**  
THK. 1.0mm - 0.741 Kg/m

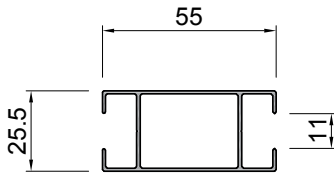

**070DR1018**  
THK. 1.0mm - 0.518 Kg/m

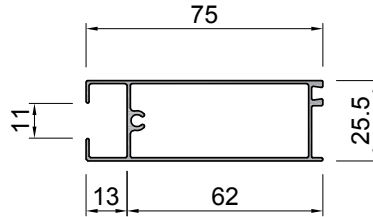

**070DR1004**  
THK. 1.0mm - 0.635 Kg/m

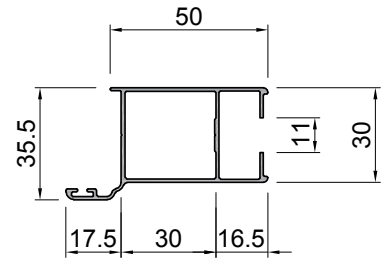

**070DR1006**  
THK. 1.1mm - 0.588 Kg/m

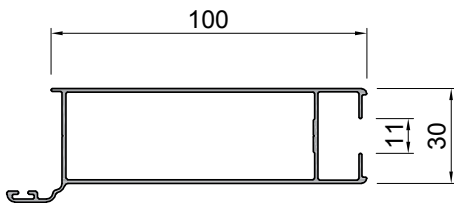

**070DR1016**  
THK. 1.0mm - 0.887 Kg/m

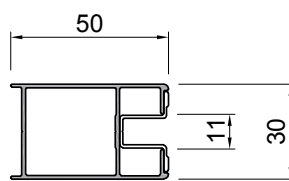

**070DR1007**  
THK. 1.1mm - 0.514 Kg/m



**070DR1017**  
THK. 1.0mm - 0.812 Kg/m

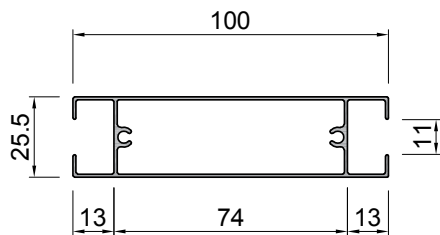

**070DR1008**  
THK. 1.0mm - 0.815 Kg/m

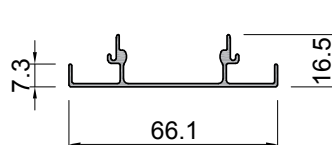

**070DR1028**  
THK. 1.0mm - 0.372 Kg/m

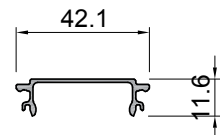

**070DR1038**  
THK. 1.0mm - 0.230 Kg/m



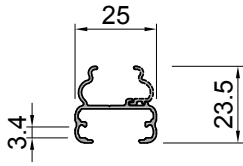

**070DR1009**  
THK. 0.9mm - 0.209 Kg/m

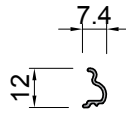

**070DR1019**  
THK. 0.9mm - 0.053 Kg/m

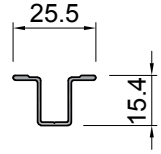

**070DR1029**  
THK. 1.0mm - 0.152 Kg/m

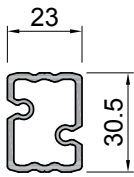

**070CP0001**  
THK. 2.0mm - 0.589 Kg/m

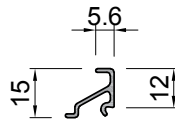

(G: 20mm)  
**090FX1049**  
THK. 1.1mm - 0.124Kg/m

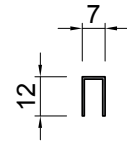

**007CN0012**  
THK. 0.7mm - 0.056Kg/m

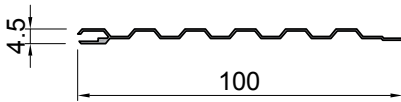

**100SP0001**  
THK. 1.0mm - 0.327 Kg/m

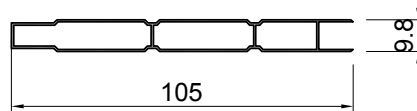

**105SP0002**  
THK. 1.0mm - 0.63 Kg/m

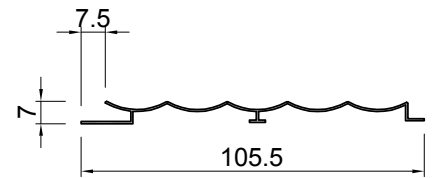

**105SP0004**  
THK. 1.0mm - 0.357 Kg/m

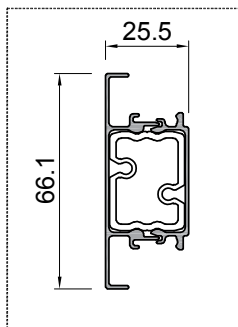

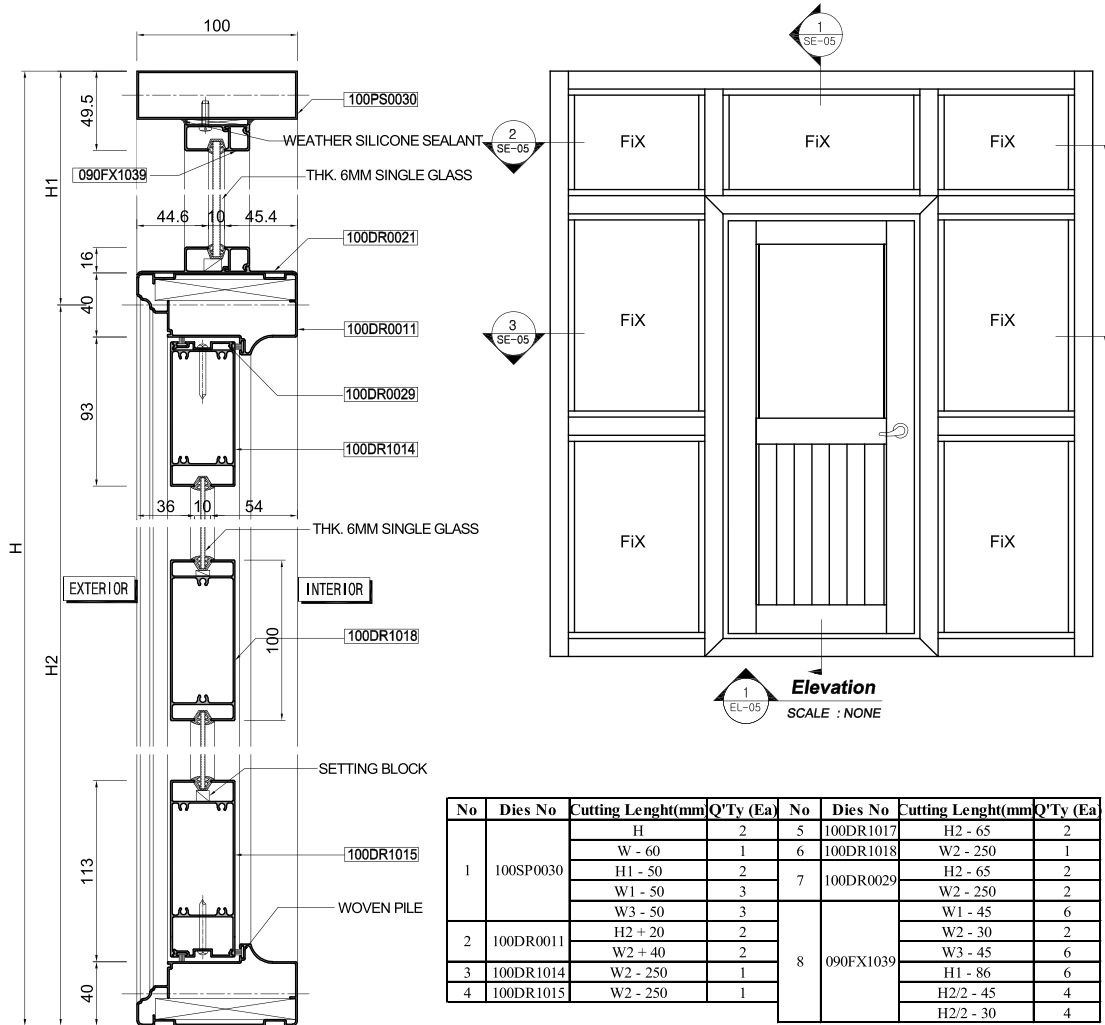

1 Vertical Section Detail  
SCALE : NONE



2 Horizontal Section Detail  
SCALE : NONE

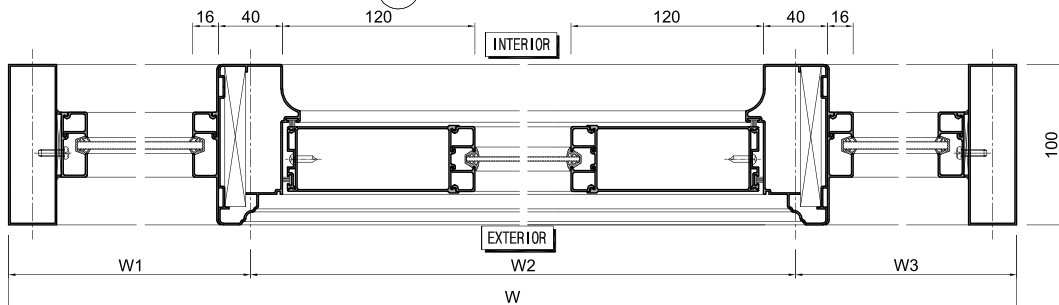

3 Horizontal Section Detail  
SCALE : NONE



# CỬA ĐI HỆ 100

Loại 2

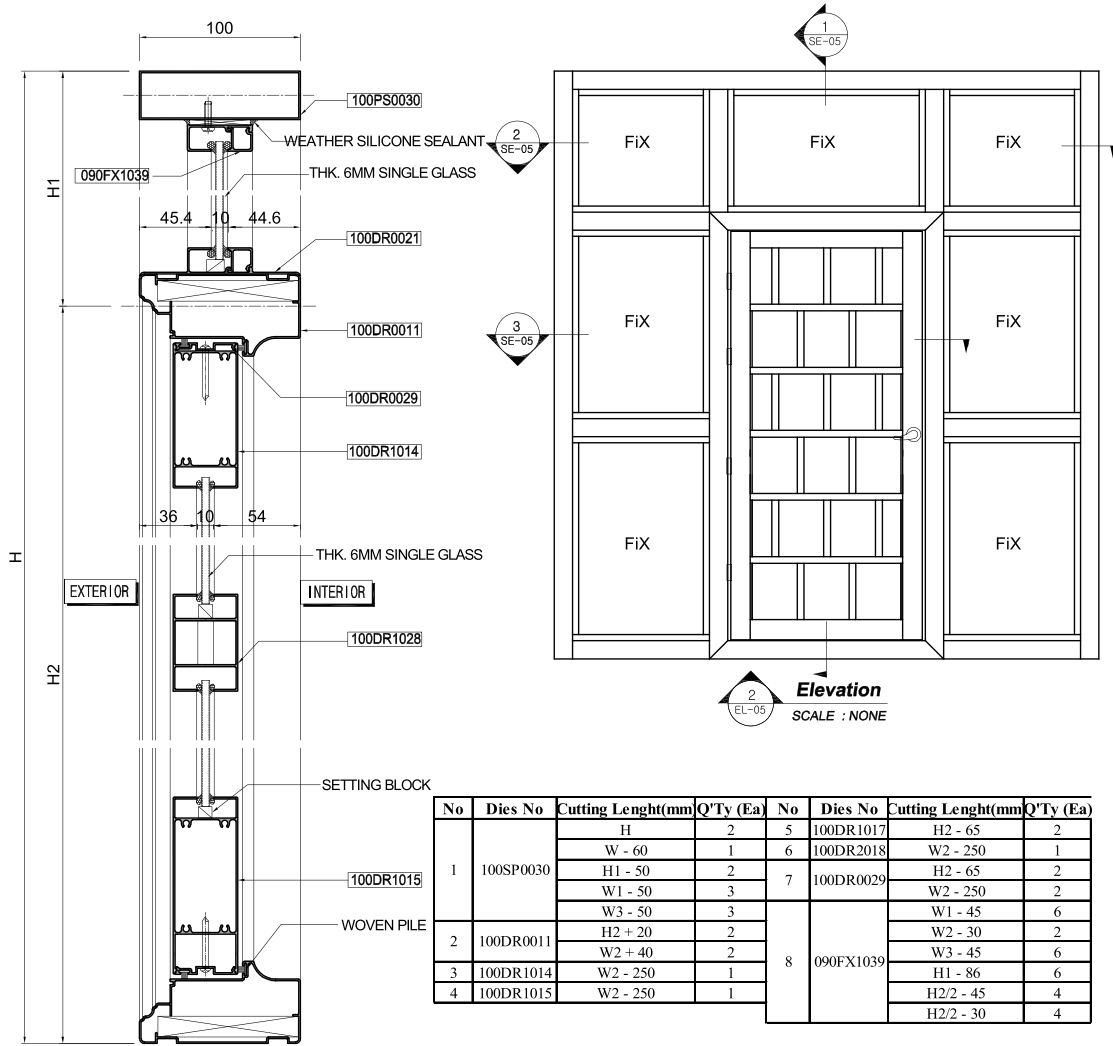

1 SE-05 Vertical Section Detail SCALE : NONE



2 SE-05 Horizontal Section Detail SCALE : NONE

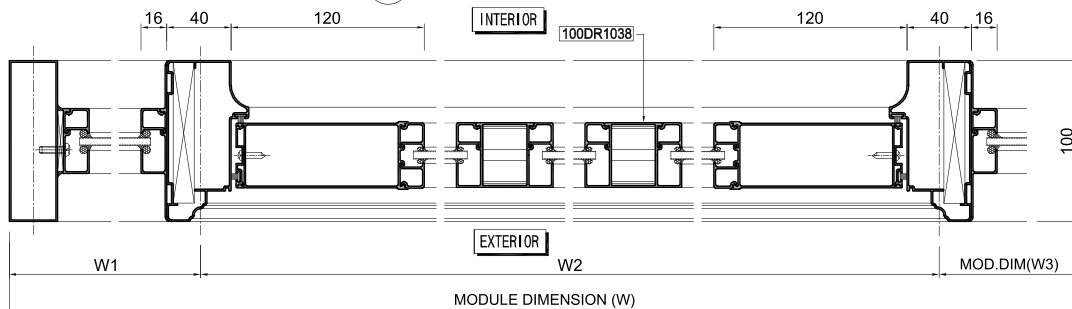

3 SE-05 Horizontal Section Detail SCALE : NONE



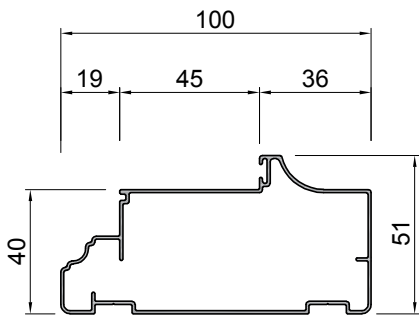

**100DR0011**  
THK.1.0mm - 0.867Kg/m

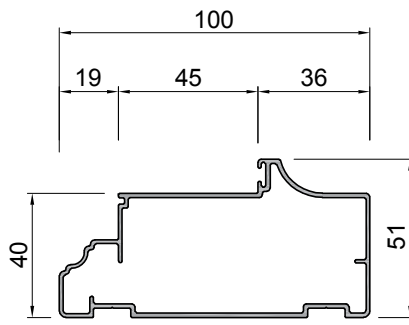

**MYA0000018**  
THK.1.4mm - 1.136Kg/m

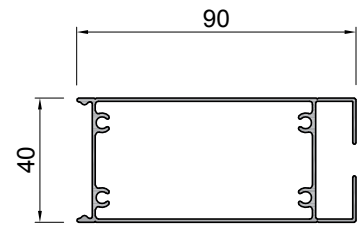

**100DR1014**  
THK.1.0mm - 0.941 Kg/m

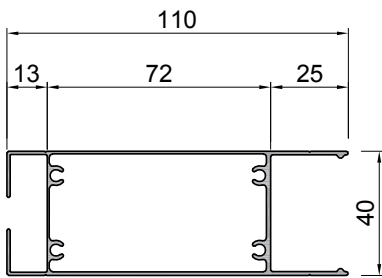

**100DR1015**  
THK.1.0mm - 1.044 Kg/m

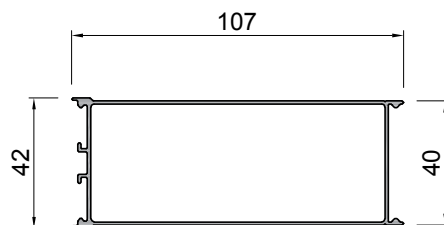

**100DR1017**  
THK.1.0mm - 0.859 Kg/m

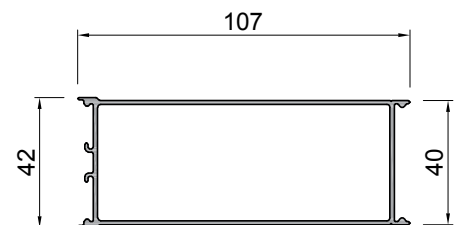

**MYA0000019**  
THK.1.2mm - 1.037Kg/m

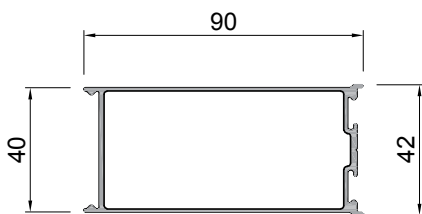

**MP0000002**  
THK. 1 mm - 0.876 Kg/m

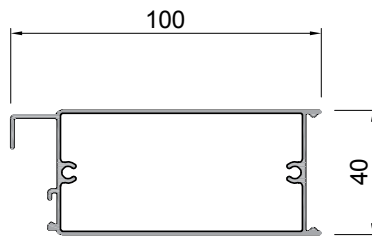

**MP0000004**  
THK. 1 mm - 0.875 Kg/m

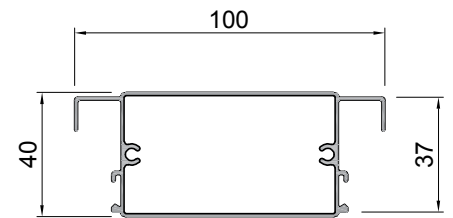

**MP0000005**  
THK. 1 mm - 0.878 Kg/m

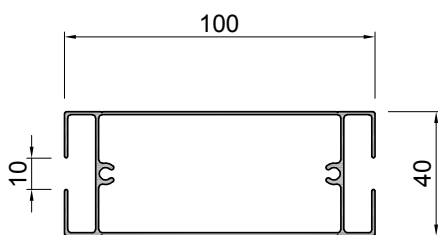

**100DR1018**  
THK.1.0mm - 0.997 Kg/m

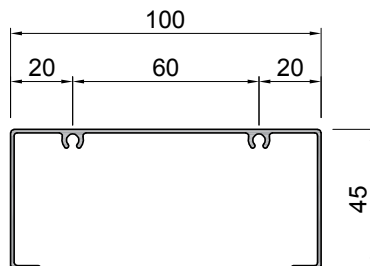

**100CN0045**  
THK. 1.1 mm - 0.706 Kg/m

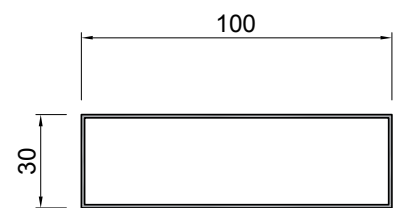

**100PS0030**  
THK.1.0mm - 0.694 Kg/m

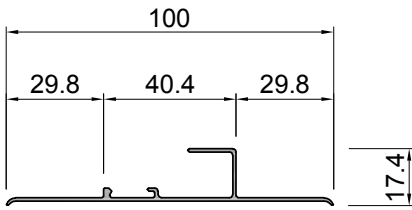

**100DR0021**  
THK.1.0mm - 0.381Kg/m

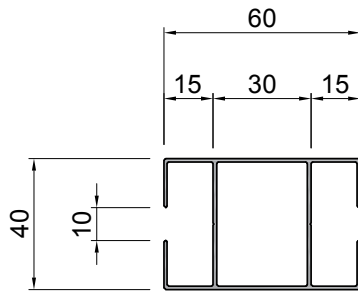

**100DR1028**  
THK.1.0mm - 0.724 Kg/m

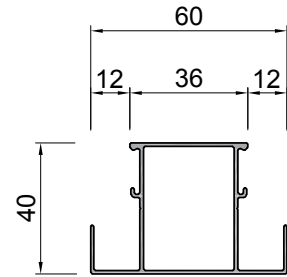

**100DR1038**  
THK.1.0mm - 0.621 Kg/m

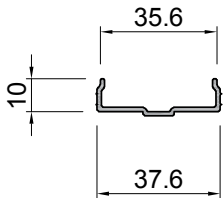

**100DR0049**  
THK.1.3 mm - 0.204 Kg/m

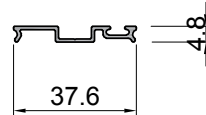

**100DR0029**  
THK.1.0mm - 0.159 Kg/m

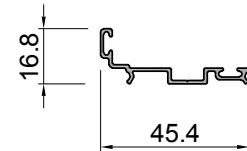

**100DR0039**  
THK.1.0mm - 0.224 Kg/m

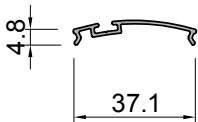

**100DR0059**  
THK.1.0mm - 0.153 Kg/m

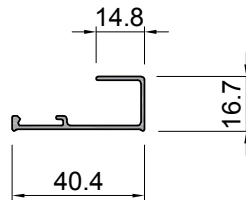

**090FX1029**  
THK.1.1mm - 0.241 Kg/m

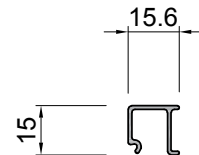

**090FX1039**  
THK.1.1mm - 0.145 Kg/m

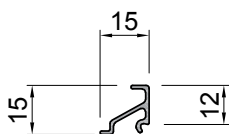

**090FX1049**  
THK.1.1mm - 0.124 Kg/m

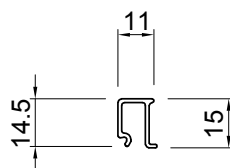

**MP000003**  
THK. 1.1 mm - 0.131 Kg/m

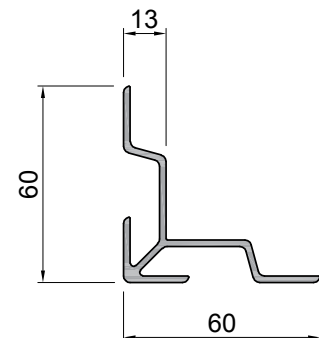

**060CP0013**  
THK.2.0mm - 0.882 Kg/m



# CỬA MỞ XOAY VÀ CỐ ĐỊNH HỆ 100

Loại 3

Công nghệ làm nên tương lai phần vịnh

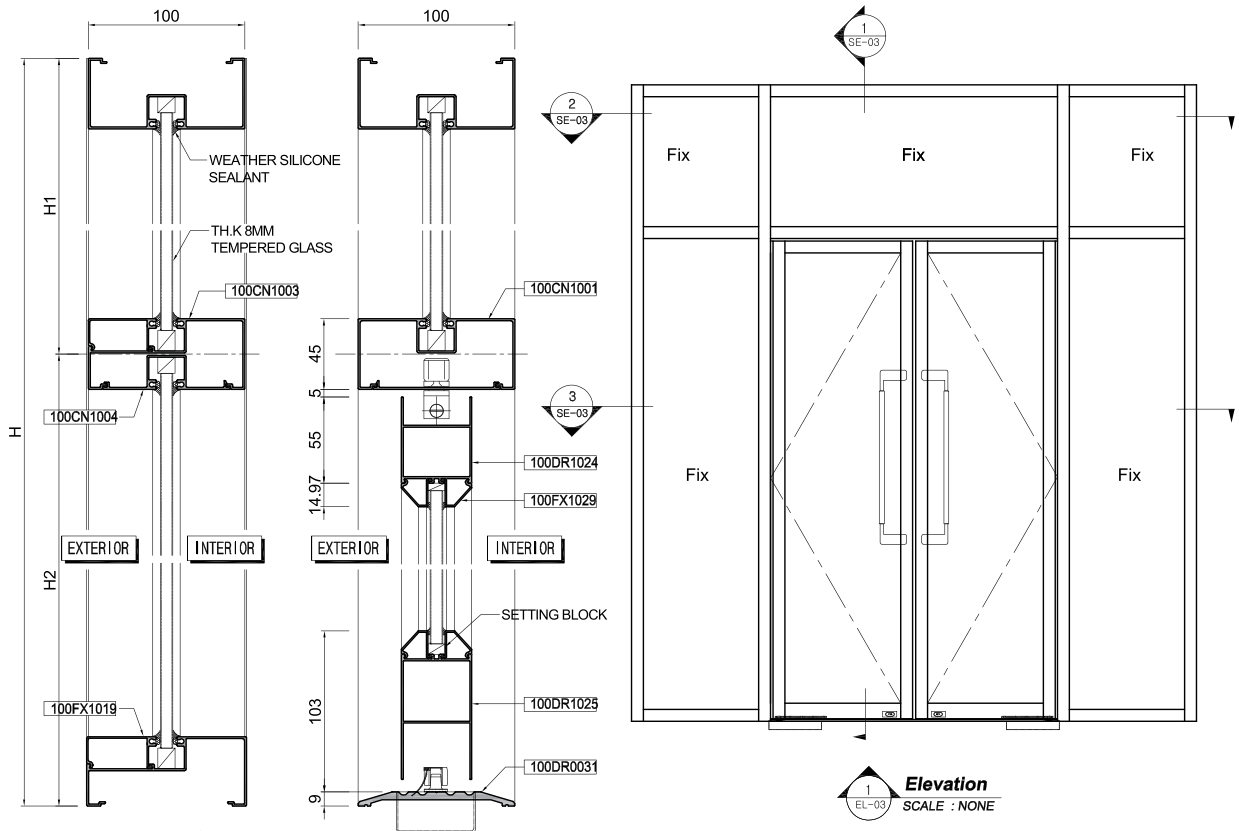

**Vertical Section Detail**  
SCALE : NONE

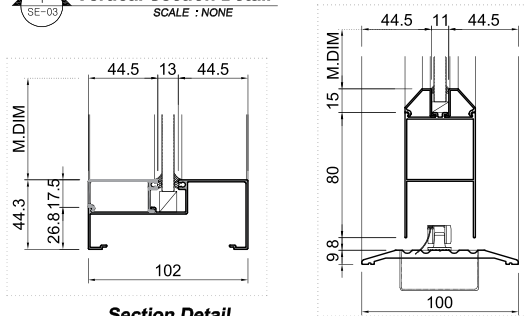

| No | Des No    | Cutting Length(mm) | QTY(EA) |
|----|-----------|--------------------|---------|
| 1  | 100CN101  | H                  | 4       |
|    |           | W1-67.5            | 1       |
|    |           | 2W2-45             | 2       |
| 2  | 100CN102  | W3-67.5            | 1       |
|    |           | 2W2-45             | 1       |
|    |           | H2-22.5            | 2       |
| 3  | 100CN103  | W1-67.5            | 2       |
|    |           | W3-67.5            | 2       |
|    |           | W1-67.5            | 1       |
| 4  | 100CN104  | W3-67.5            | 1       |
|    |           | H1-67.5            | 2       |
| 5  | 100DR1024 | W2-138,65          | 2       |
| 6  | 100DR1025 | W2-138,65          | 2       |
| 7  | 100DR1027 | H2-44,5            | 2       |
| 8  | 100FX1029 | H2-58              | 2       |
| 9  | 110SL2017 | H2-58              | 2       |
| 10 | 110FX1019 | W1-67.5            | 2       |
|    |           | W3-67.5            | 2       |
| 11 | 110FX1029 | W2-138,65          | 2       |
|    |           | H2-44,5            | 4       |

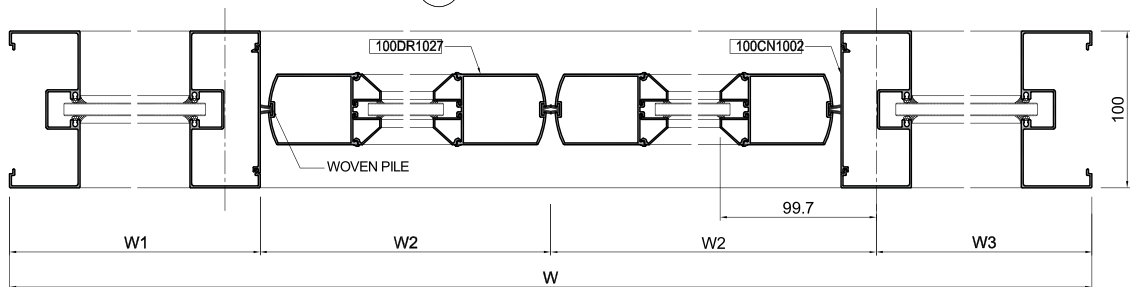
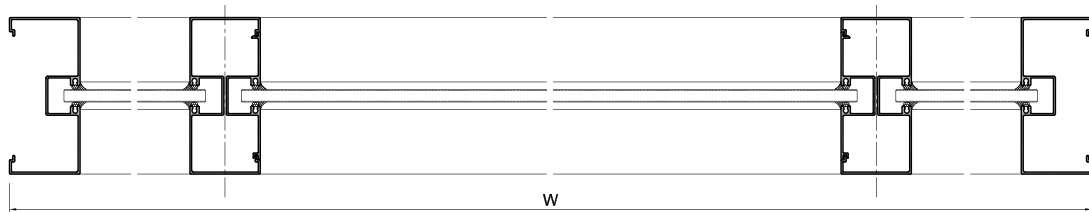

**Horizontal Section Detail**  
SCALE : NONE





# CỬA MỞ XOAY VÀ CỔ ĐINH HỆ 100

Loại 3

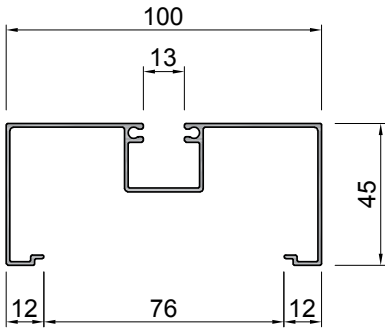

**100CN1001**  
THK. 1.2mm - 0.909 Kg/m

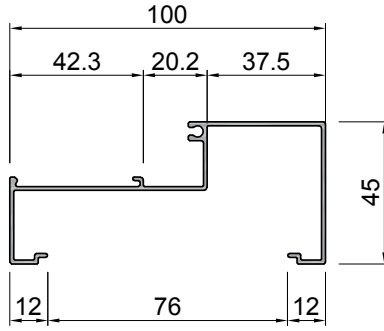

**100CN1002**  
THK. 1.2mm - 0.765Kg/m

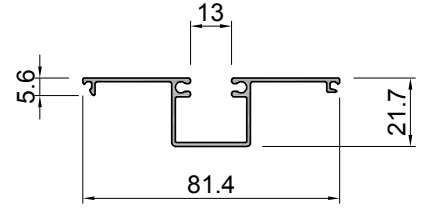

**100CN1003**  
THK. 1.2mm - 0.511Kg/m

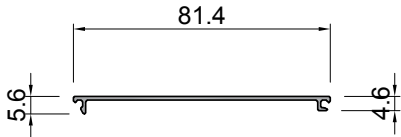

**100CN1004**  
THK. 1.2mm - 0.297 Kg/m

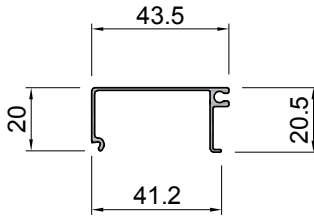

**100FX1019**  
THK. 1.2mm - 0.252 Kg/m

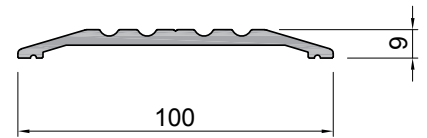

**100DR0031**  
THK. 5.0mm - 1.089 Kg/m

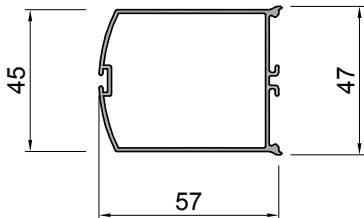

**100DR1027**  
THK. 1.2mm - 0.706 Kg/m

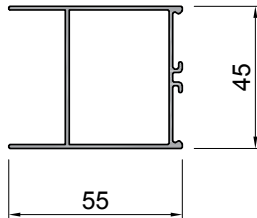

**100DR1024**  
THK. 1.2mm - 0.678 Kg/m

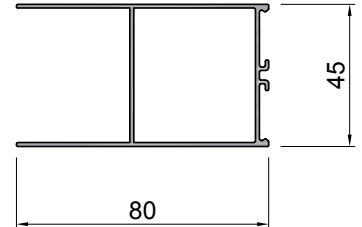

**100DR1025**  
THK. 1.2mm - 0.841 Kg/m

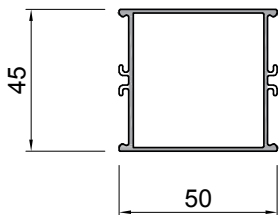

**100DR1048**  
THK. 1.2mm - 0.724 Kg/m

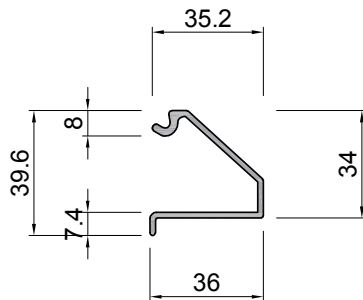

**100FX1029**  
THK. 1.2mm - 0.504 Kg/m

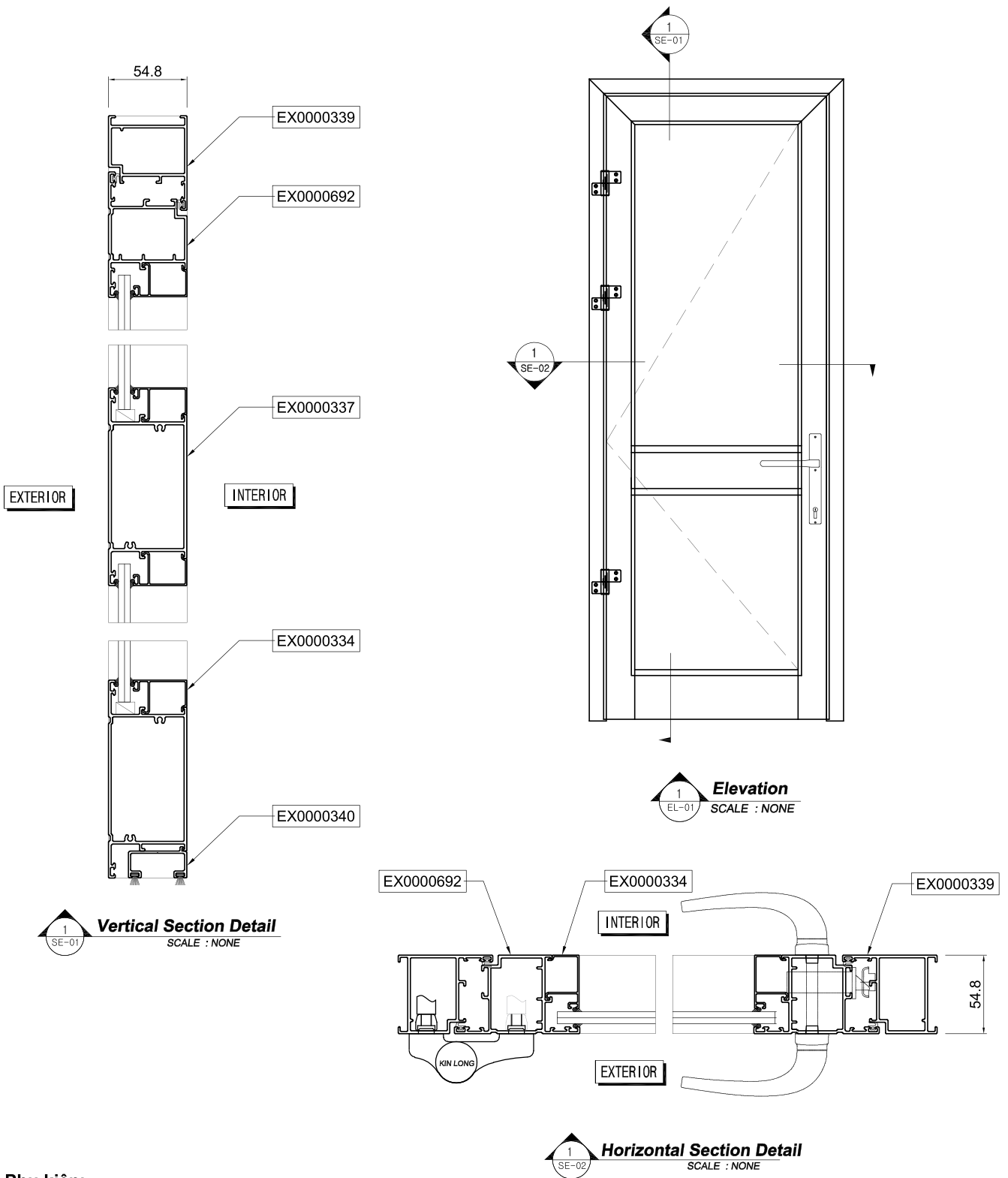

Phụ kiện:

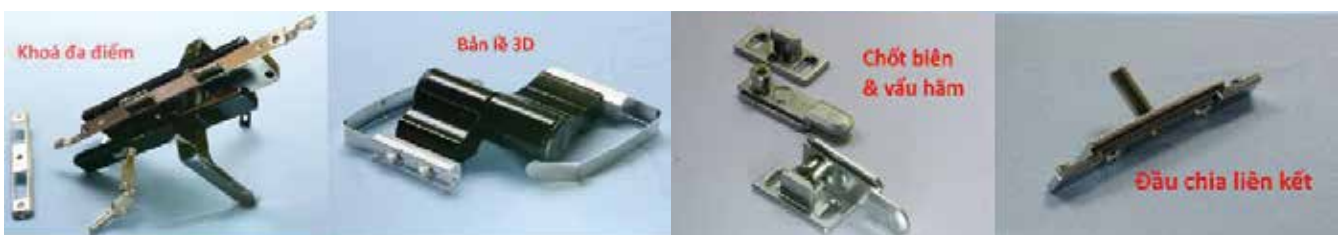

# CỬA ĐI VÀ CỐ ĐỊNH HỆ HD55

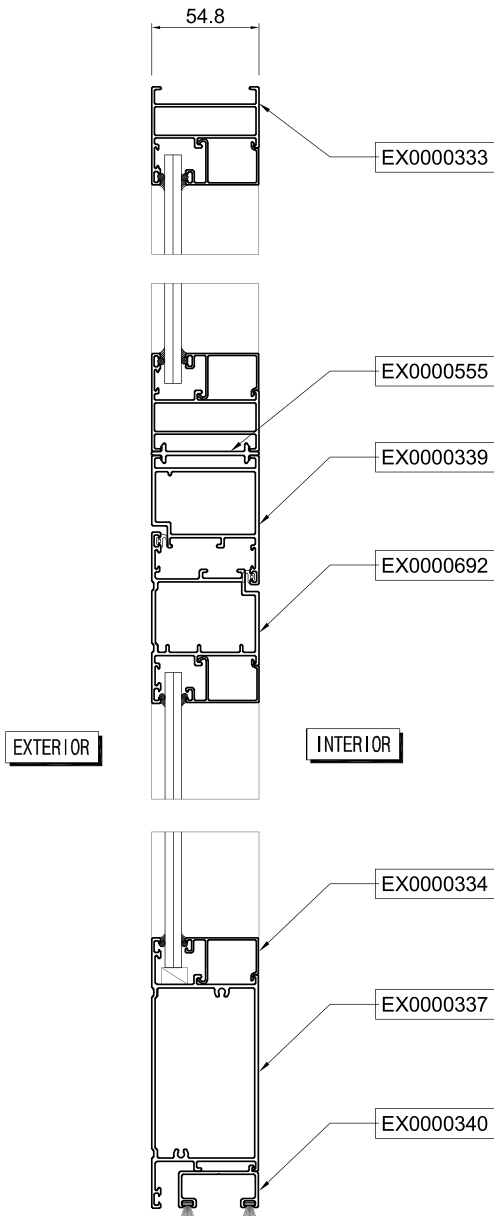

**Vertical Section Detail**  
SCALE : NONE

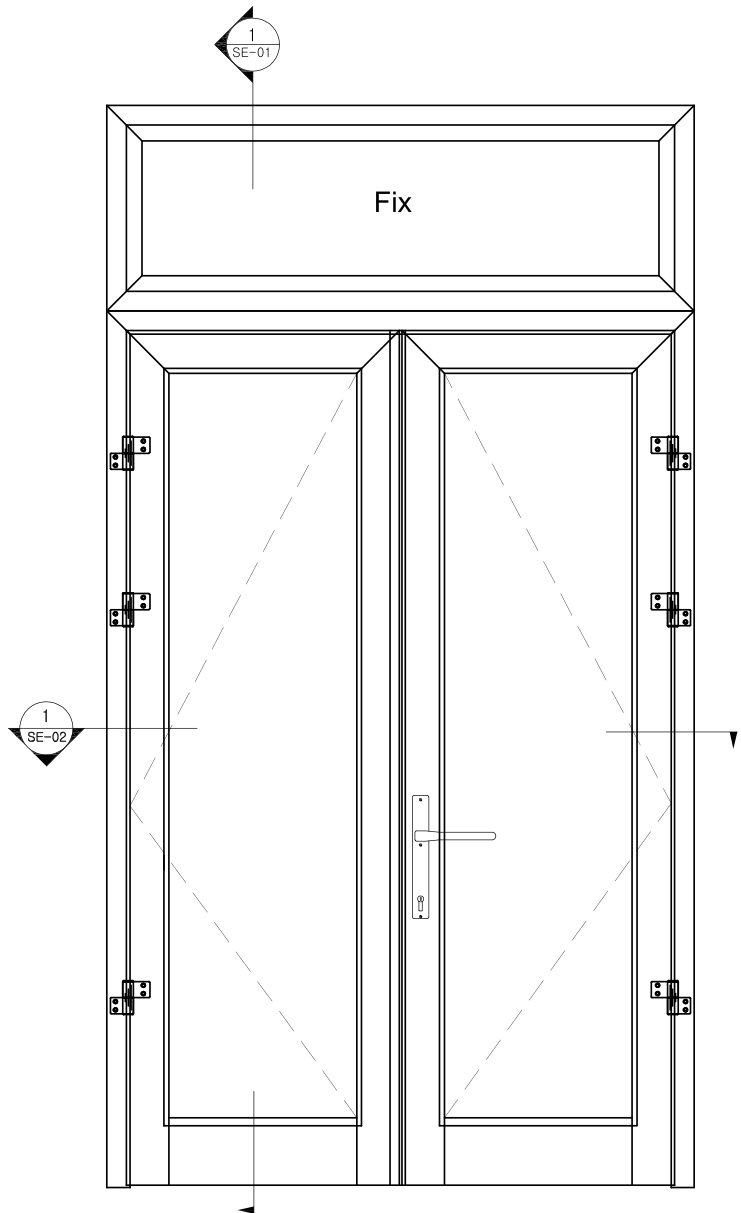

**Elevation**  
SCALE : NONE

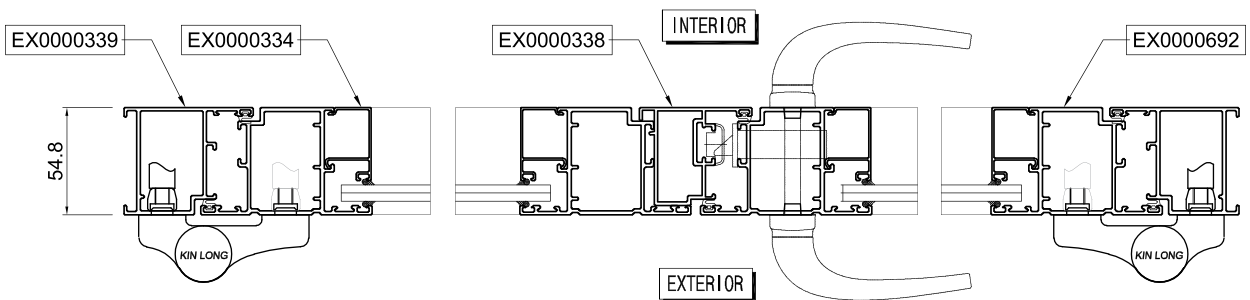

**Horizontal Section Detail**  
SCALE : NONE



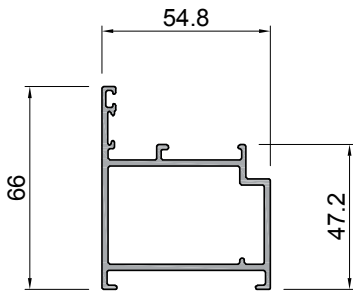

**EX0000339 (C3328)**  
THK. 2.0 mm - 1.230 Kg/m

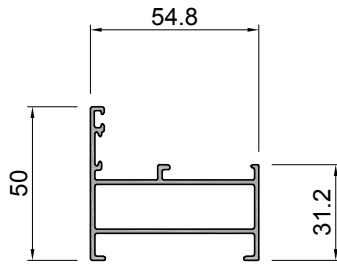

**EX0000333 (C3209)**  
THK. 1.4 mm - 0.805 Kg/m

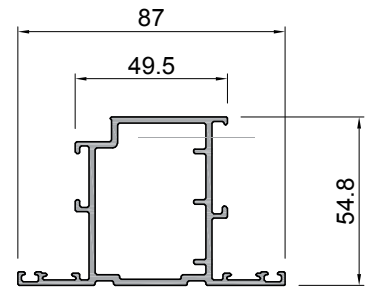

**EX0000692 (C3303)**  
THK. 2.0 mm - 1.447 Kg/m

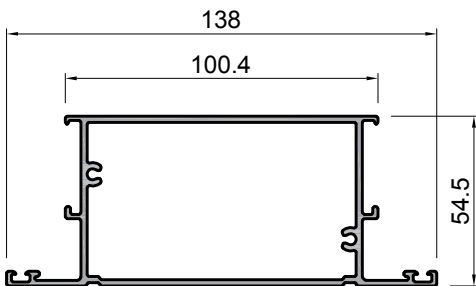

**EX0000337 (C3304)**  
THK. 2.0 mm - 2.028 Kg/m

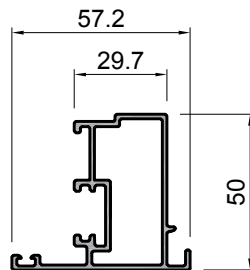

**EX0000338 (C3323)**  
THK. 1.5 mm - 0.961 Kg/m

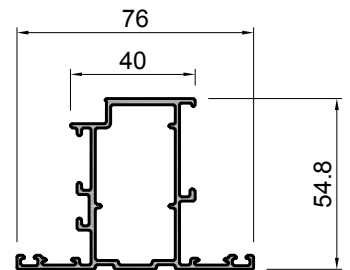

**EX0000330 (C3202)**  
THK. 1.4 mm - 1.092 Kg/m

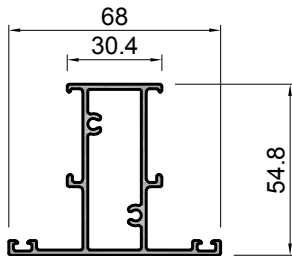

**EX0000331 (C3203)**  
THK. 1.6 mm - 1.072 Kg/m

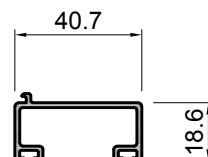

**EX0000340 (C3329)**  
THK. 1.5 mm - 0.414 Kg/m

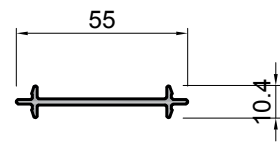

**EX0000555 (C3300)**  
THK. 2.0 mm - 0.348 Kg/m

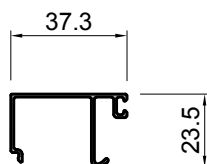

**EX0000334 (C3295)**  
THK. 1.0 mm - 0.272 Kg/m

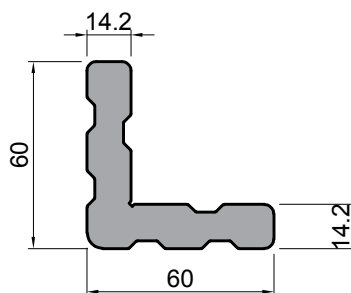

**EX0000341 (C1687)**  
THK. 14.2 mm - 3.668 Kg/m

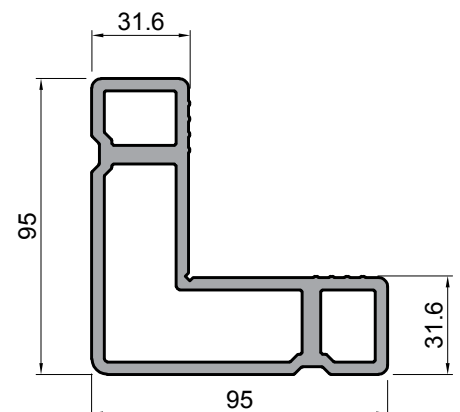

**EX0000352 (F347)**  
THK. 4.0 mm - 4.620 Kg/m

# CỬA ĐI VÀ CỐ ĐỊNH HỆ HD450

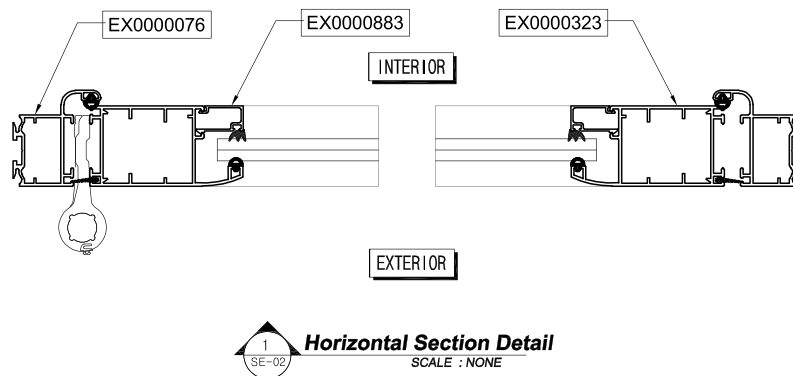
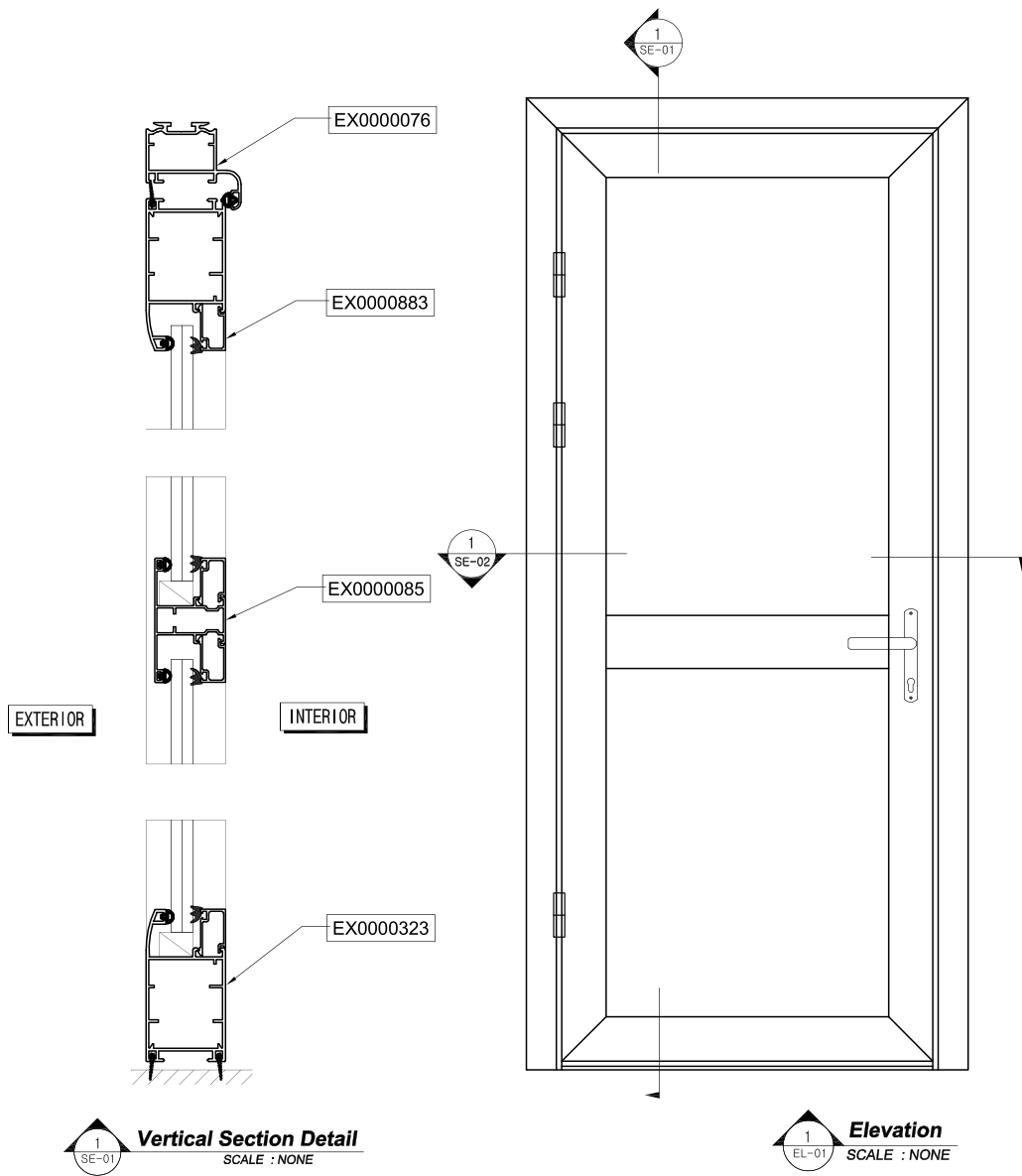

Phụ kiện:



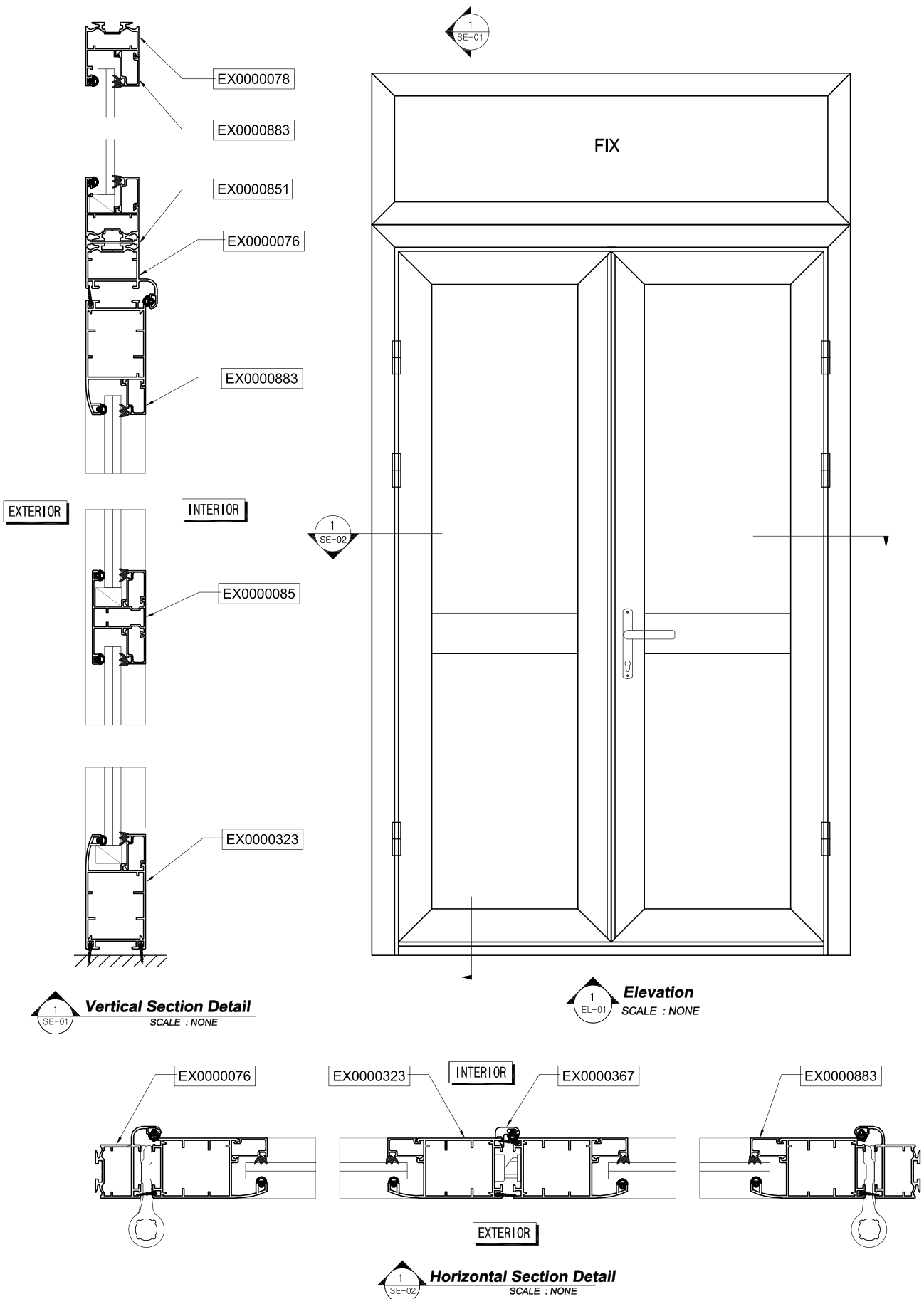



# CỬA ĐI VÀ CỔ ĐỊNH HỆ HD450

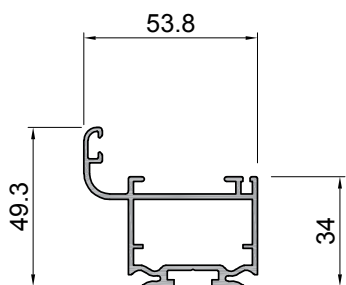

**EX0000076 (450)**  
THK. 1.55 mm - 0.945 Kg/m

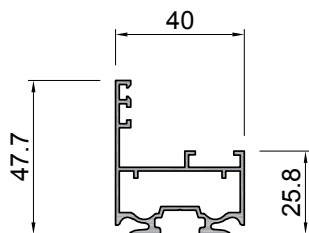

**EX0000078 (4420)**  
THK. 1.25 mm - 0.703 Kg/m

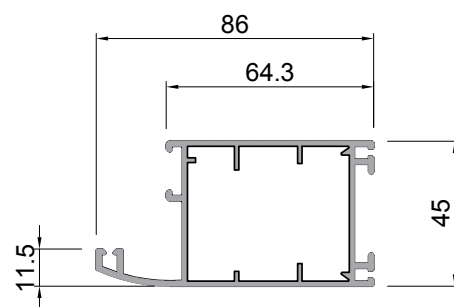

**EX0000323 (4451)**  
THK. 1.6 mm - 1.317 Kg/m

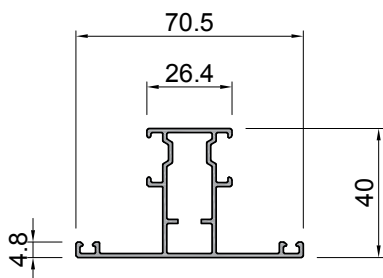

**EX0000085 (4405)**  
THK. 1.25 mm - 0.733 Kg/m

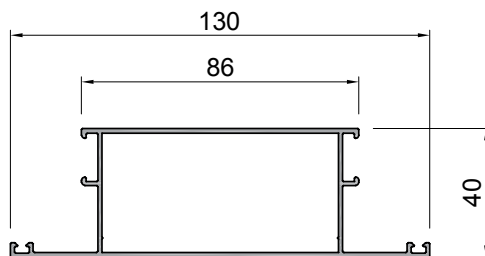

**EX0000592 (4450)**  
THK. 1.5 mm - 1.217 Kg/m

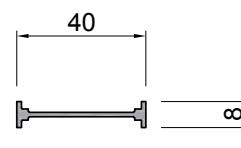

**EX0000851 (433)**  
THK. 1.4 mm - 0.225 Kg/m

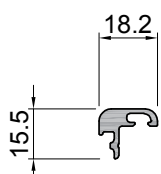

**EX0000367 (4504)**  
THK. 1.5 mm - 0.252 Kg/m

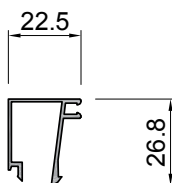

**EX0000084 (5016)**  
THK. 0.9 mm - 0.248 Kg/m

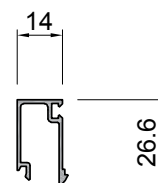

**EX00000883 (5026)**  
THK. 1.0 mm - 0.224 Kg/m

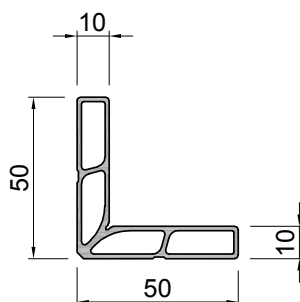

**EX0000112**  
THK. 1.4 mm - 0.853 Kg/m

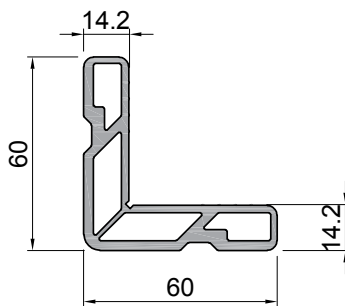

**EX0000327**  
THK.3.0 mm - 1.911 Kg/m

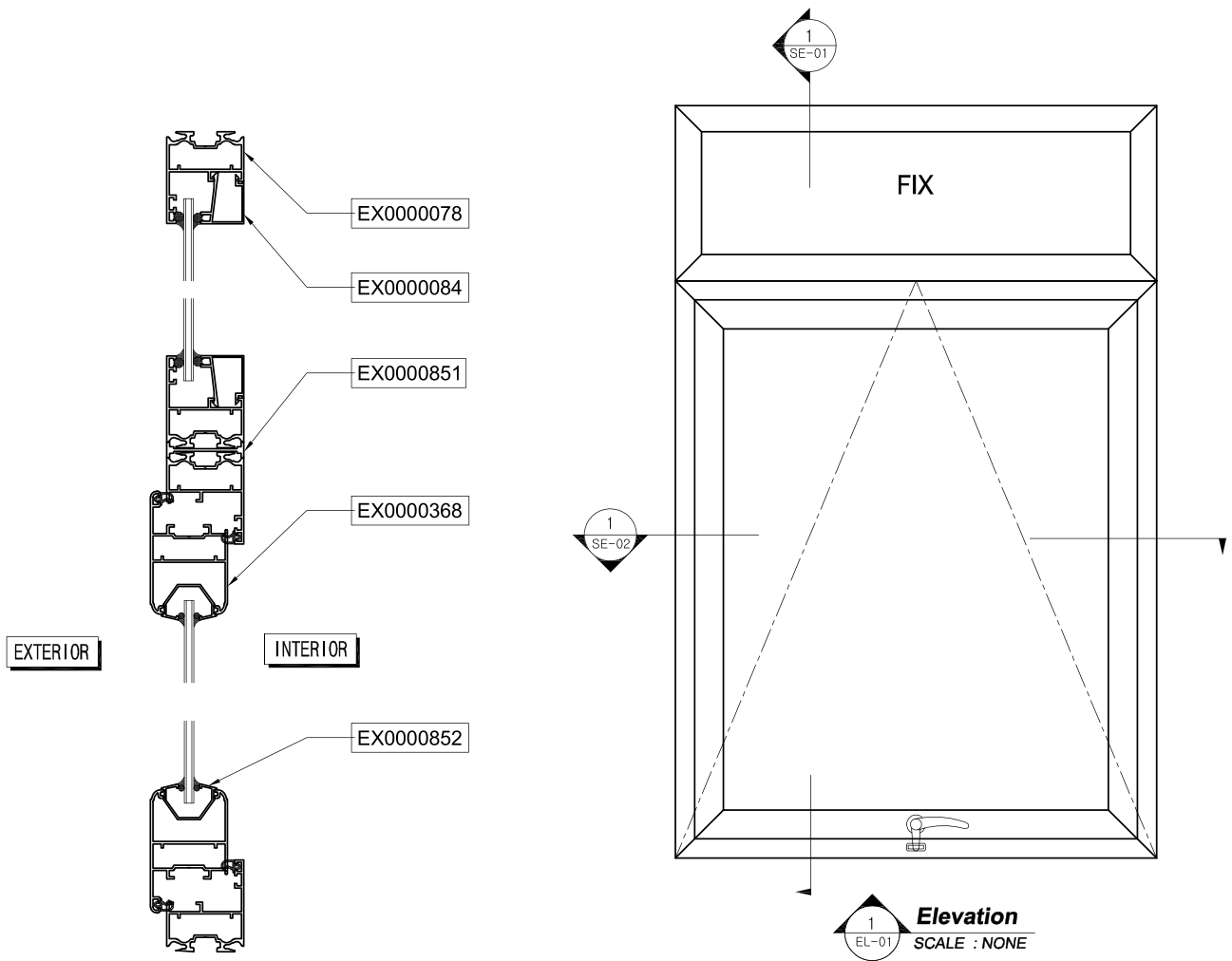

**Vertical Section Detail**  
SCALE : NONE

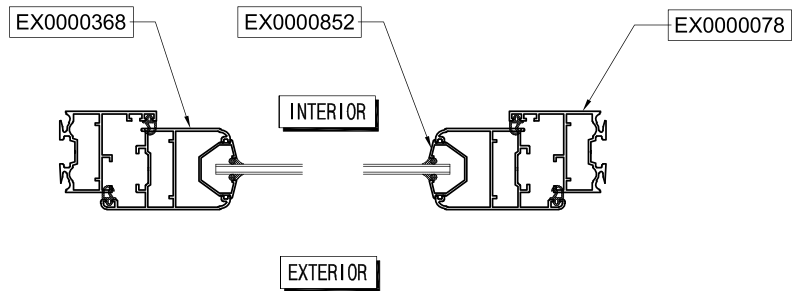

**Horizontal Section Detail**  
SCALE : NONE

**Phụ kiện:**



# CỬA ĐI VÀ CỬA SỔ HỆ HD4400

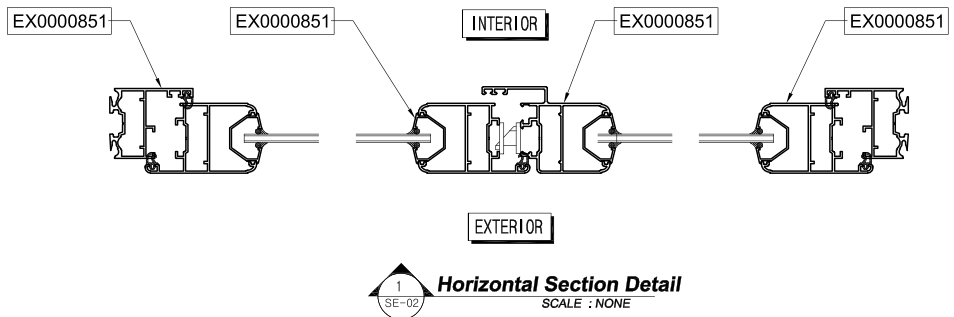
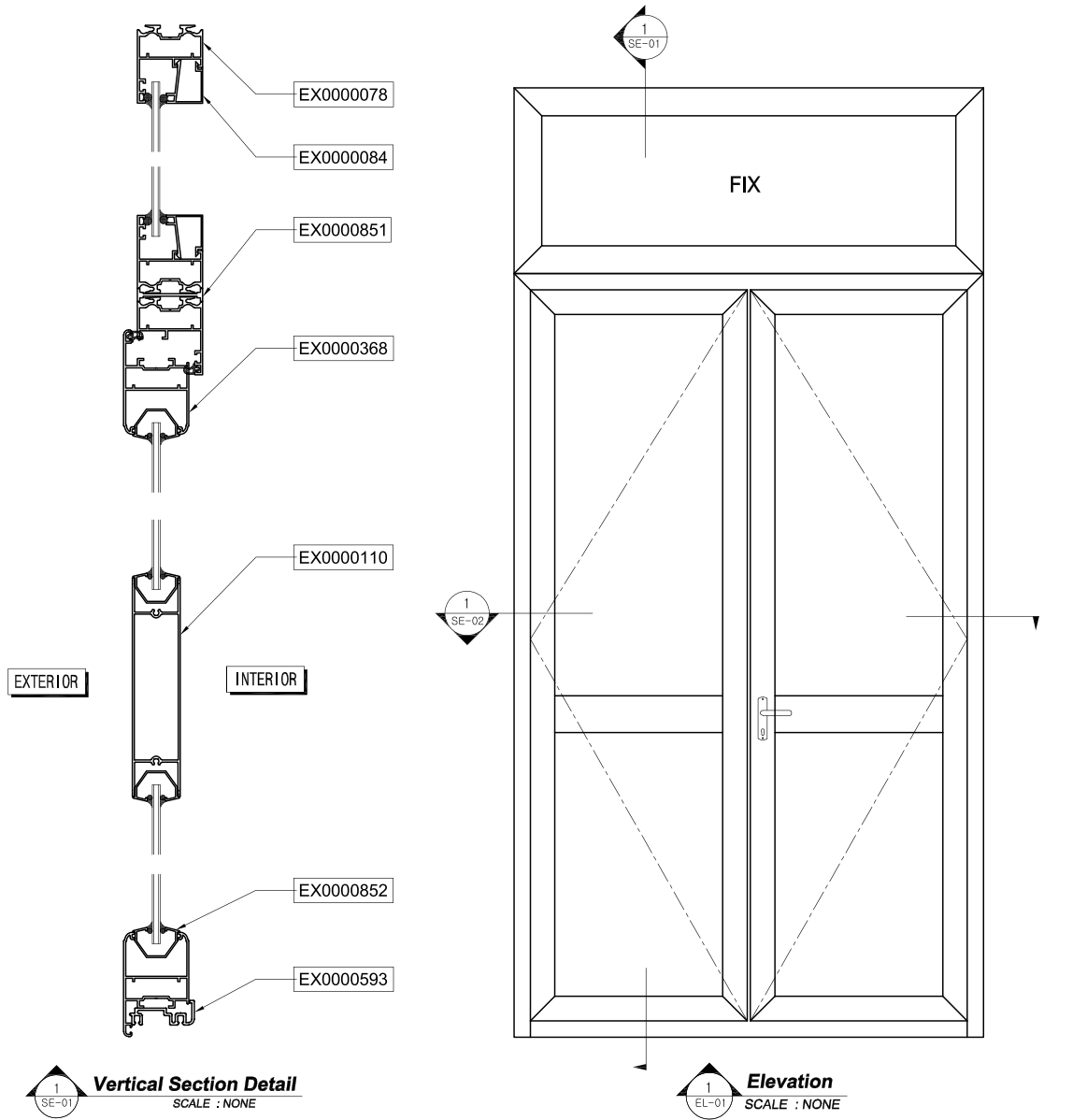

Phụ kiện:





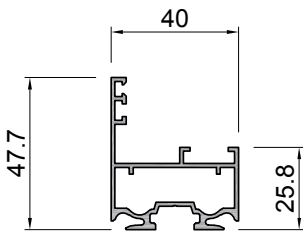

**EX0000078 (4420)**  
THK. 1.25 mm - 0.703 Kg/m

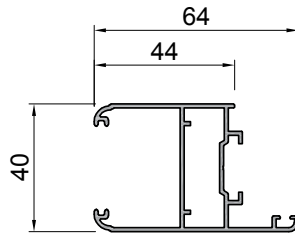

**EX0000368 (4410)**  
THK. 1.25 mm - 0.770 Kg/m

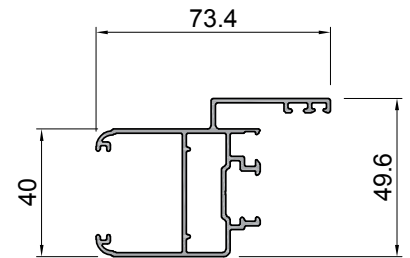

**EX0000055 (4482)**  
THK. 1.3 mm - 0.980 Kg/m

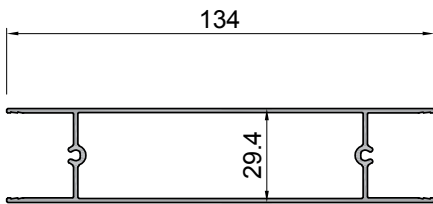

**EX0000110 (2672)**  
THK. 1.2 mm - 1.161 Kg/m

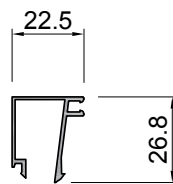

**EX0000084 (5016)**  
THK. 0.9 mm - 0.248 Kg/m

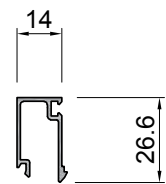

**EX00000883 (5026)**  
THK. 1.0 mm - 0.224 Kg/m

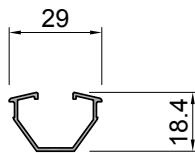

**EX0000852 (26561)**  
THK. 1.0 mm - 0.183 Kg/m

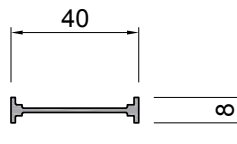

**EX0000851 (433)**  
THK. 1.4 mm - 0.225 Kg/m

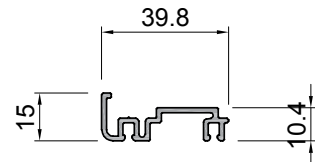

**EX0000593 (4587)**  
THK. 1.5 mm - 0.379 Kg/m

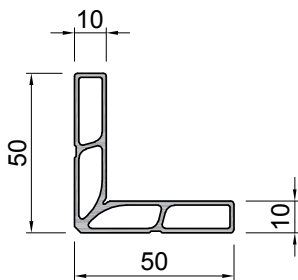

**EX0000112**  
THK. 1.4 mm - 0.853 Kg/m

# CỬA TRƯỢT VÀ CỐ ĐỊNH HỆ 80



**CỬA TRƯỢT HỆ 80mm**



**CỬA TRƯỢT VÀ CỐ ĐỊNH HỆ 80mm**

**Đặc tính:**

Kết cấu thanh trượt dạng bậc thang nên tính năng ngăn nước mưa tốt. Phù hợp cho những ô cửa có không gian hạn chế

- Màu sắc đa dạng (Sơn tĩnh điện, PVDF, vân gỗ, Anodized...), có thể đáp ứng những yêu cầu khắt khe nhất của từng hạng mục công trình

**Mặt đứng**

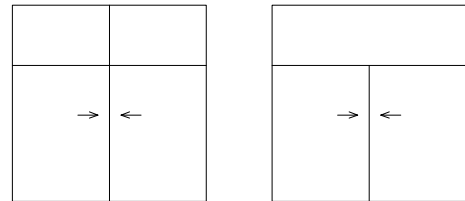
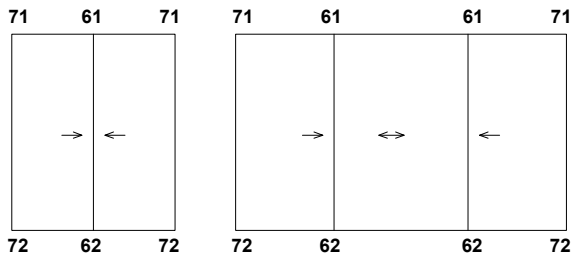

**Phụ kiện**



**GD080-61**



**GD080-62**



**GD080-71**



**GD080-72**



**GD080-17**



**AT 090-1**



**HC 12-11**



**WP 60-50**



**WP 60-60**



**GKH-001**



**GKO-001**



**RL 090-01**



**LDSL-001**



**LDSR-001**



**Screen Coner**

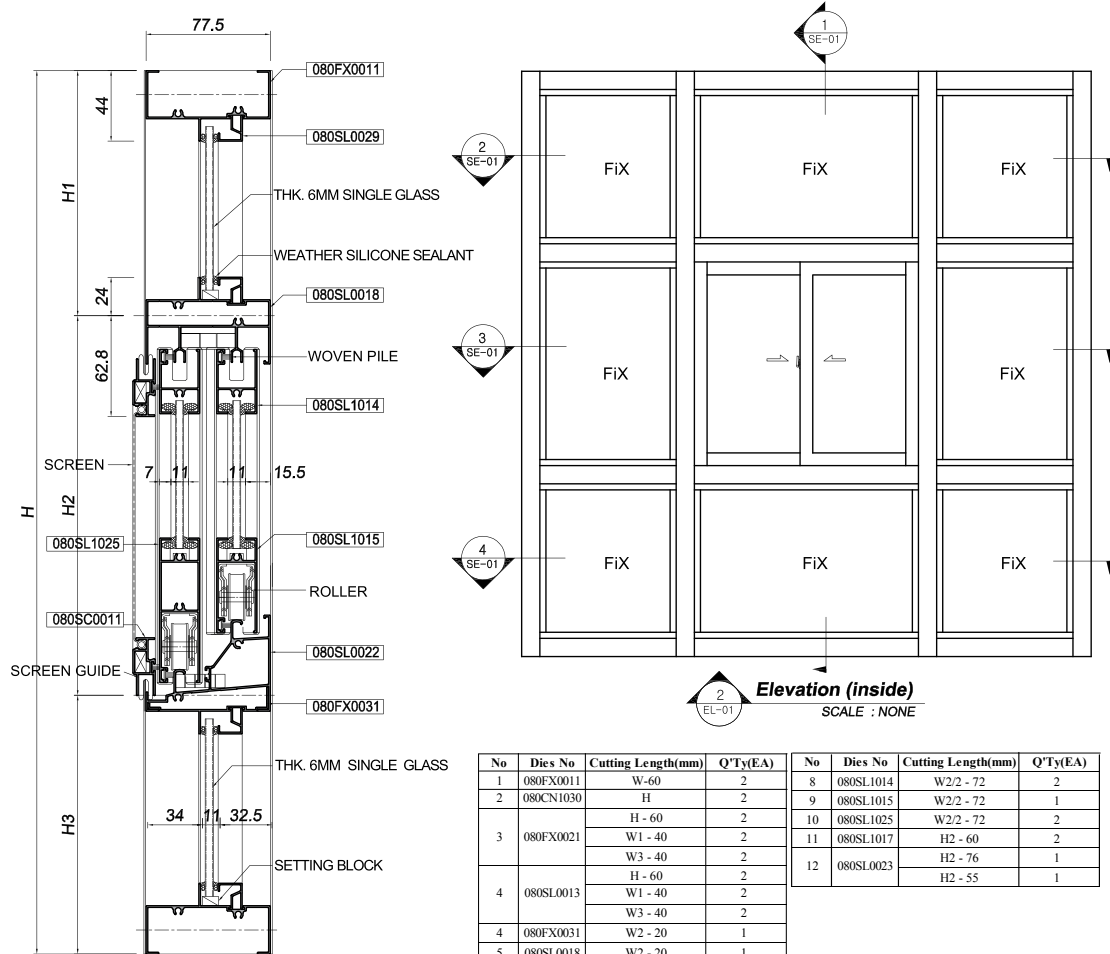

**1 Vertical Section Detail**  
SCALE : NONE

**2 Elevation (inside)**  
SCALE : NONE

| No | Dies No   | Cutting Length(mm) | Q'Ty(EA) | No | Dies No   | Cutting Length(mm) | Q'Ty(EA) |
|----|-----------|--------------------|----------|----|-----------|--------------------|----------|
| 1  | 080FX0011 | W-60               | 2        | 8  | 080SL1014 | W2/2 - 72          | 2        |
| 2  | 080CN1030 | H                  | 2        | 9  | 080SL1015 | W2/2 - 72          | 1        |
| 3  | 080FX0021 | H - 60             | 2        | 10 | 080SL1025 | W2/2 - 72          | 2        |
|    |           | W1 - 40            | 2        | 11 | 080SL1017 | H2 - 60            | 2        |
|    |           | W3 - 40            | 2        | 12 | 080SL0023 | H2 - 76            | 1        |
| 4  | 080SL0013 | H - 60             | 2        |    |           | H2 - 55            | 1        |
|    |           | W1 - 40            | 2        |    |           |                    |          |
|    |           | W3 - 40            | 2        |    |           |                    |          |
| 4  | 080FX0031 | W2 - 20            | 1        |    |           |                    |          |
| 5  | 080SL0018 | W2 - 20            | 1        |    |           |                    |          |
| 6  | 080SL0012 | W2 - 20            | 1        |    |           |                    |          |
| 7  | 080SL0029 | W1 - 30            | 6        |    |           |                    |          |
|    |           | W2 - 20            | 4        |    |           |                    |          |
|    |           | W3 - 30            | 6        |    |           |                    |          |
|    |           | H1 - 54            | 6        |    |           |                    |          |
|    |           | H2 - 48            | 4        |    |           |                    |          |
|    |           | H3 - 54            | 6        |    |           |                    |          |

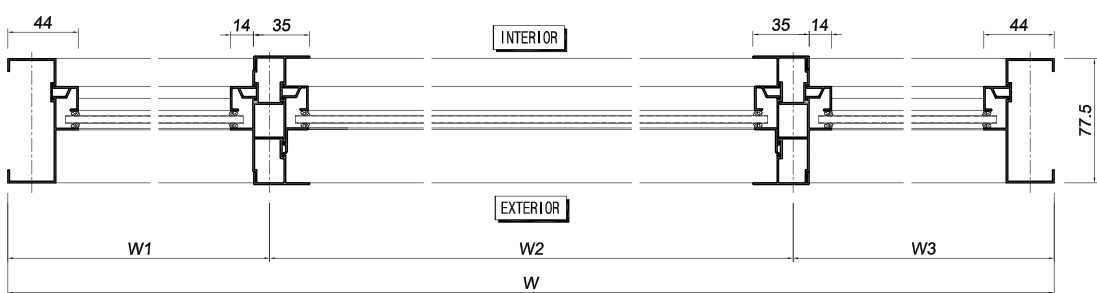

**2,4 Horizontal Section Detail**  
SCALE : NONE

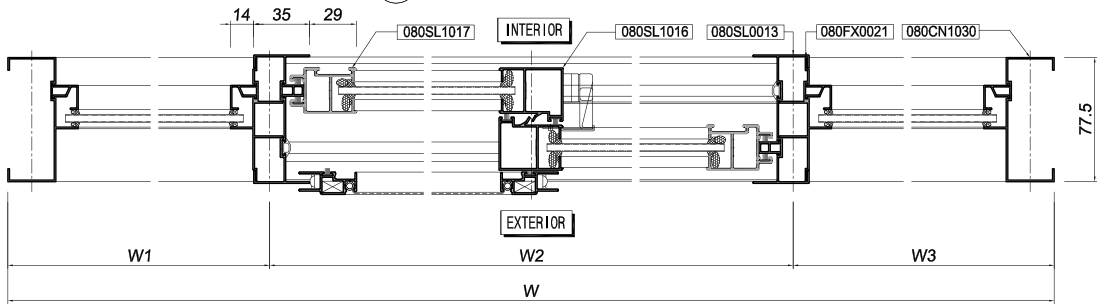

**3 Horizontal Section Detail**  
SCALE : NONE

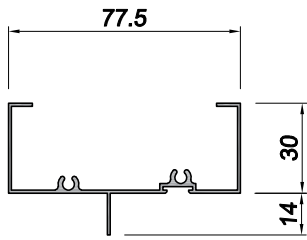

**080FX0011**  
THK. 1.0mm - 0.531 Kg/m

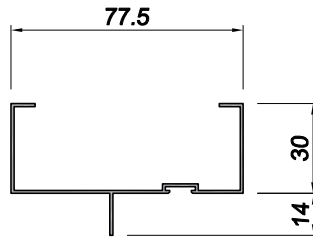

**080CN1030**  
THK. 1.0mm - 0.462 Kg/m

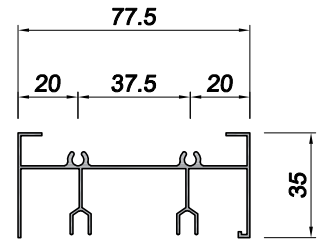

**080SL0011**  
THK. 1.0mm - 0.673 Kg/m  
**080SL0011B**  
THK. 1.2mm - 0.800 Kg/m

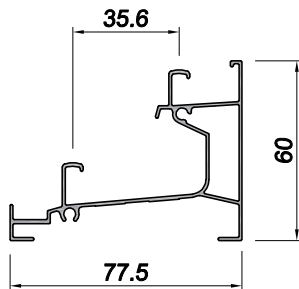

**080SL0012**  
THK. 1.0mm - 0.825 Kg/m  
**080SL0012B**  
THK. 1.2mm - 0.935 Kg/m

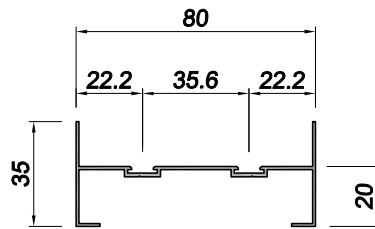

**080SL0013**  
THK. 1.0mm - 0.489 Kg/m  
**080SL0013B**  
THK. 1.2mm - 0.565 Kg/m

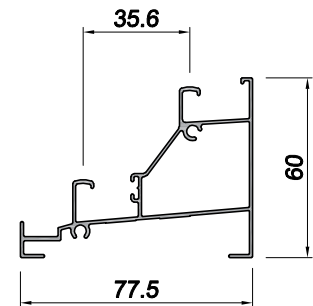

**080SL0022**  
THK. 1.0mm - 0.845 Kg/m

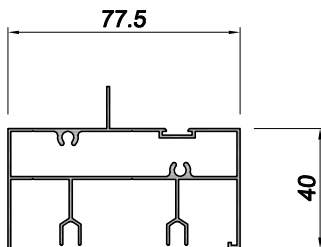

**080FS0018**  
THK. 1.0mm - 0.744 kg/m

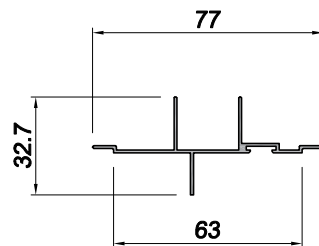

**080FX0021**  
THK. 1.0mm - 0.367 Kg/m

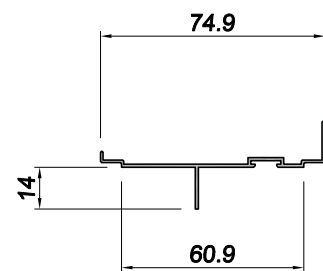

**080FX0031**  
THK. 1.0mm - 0.302 Kg/m

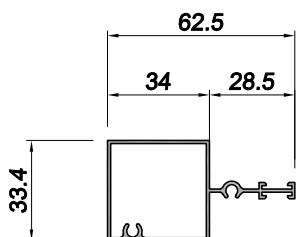

**080FX0018**  
THK. 1.0mm - 0.520 Kg/m

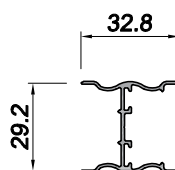

**080SL0017**  
THK. 1.0mm - 0.305 Kg/m

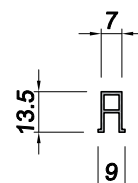

**080SL023A**  
THK. 1.0mm - 0.104 Kg/m



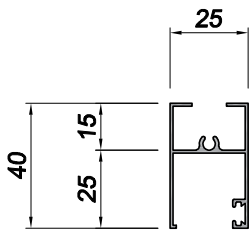

**080SL1014**  
THK. 1.0mm - 0.383 Kg/m

**080SL1014B**  
THK. 1.2mm - 0.433 Kg/m

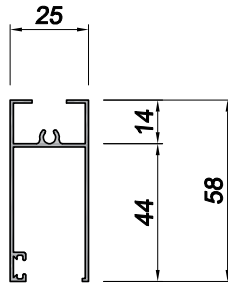

**080SL1015**  
THK. 1.0mm - 0.480 Kg/m

**080SL1015B**  
THK. 1.2mm - 0.552 Kg/m

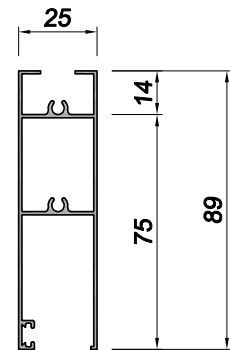

**080SL1025**  
THK. 1.0mm - 0.741 Kg/m

**080SL1025B**  
THK. 1.2mm - 0.854 Kg/m

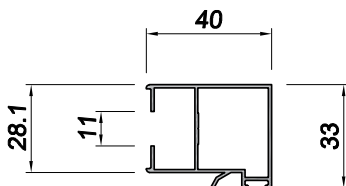

**080SL1016**  
THK. 1.0mm - 0.460 Kg/m

**080SL1016B**  
THK. 1.2mm - 0.536 Kg/m

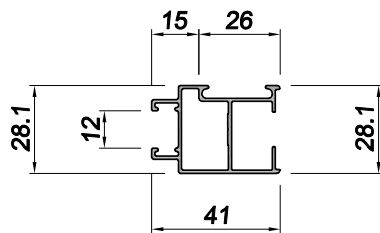

**080SL1017**  
THK. 1.0mm - 0.453 Kg/m

**080SL1017B**  
THK. 1.2mm - 0.517 Kg/m

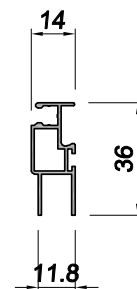

**080SC0011**  
THK. 1.1mm - 0.301 Kg/m

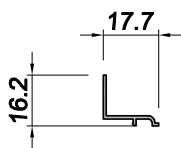

**080SL019A**  
THK. 0.7mm - 0.066 Kg/m

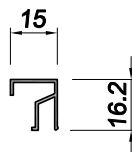

**080SL029A**  
THK. 0.9mm - 0.125 Kg/m

# CỬA TRƯỢT VÀ CỐ ĐỊNH HỆ 90



**CỬA TRƯỢT HỆ 90mm**



**CỬA TRƯỢT VÀ CỐ ĐỊNH HỆ 90mm**

**Đặc tính:**

- Đem đến phong cách hiện đại, khác biệt với cửa sổ truyền thống.
- Phù hợp cho những kiến trúc hạn chế về không gian nhưng vẫn cần sự thoáng mát.
- Màu sắc đa dạng (Sơn tĩnh điện, PVDF, vân gỗ, Anodized...), có thể đáp ứng những yêu cầu khắt khe nhất của từng hạng mục công trình

**Mặt đứng**

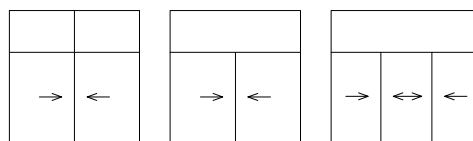
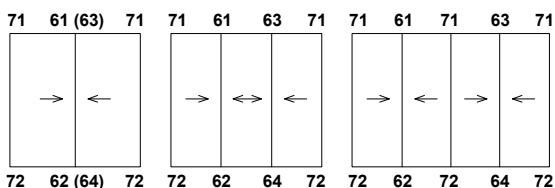

- Khóa phải dùng GD09061-GD090-62;
- Khóa trái dùng GD09063-GD090-64.

**Phụ kiện**



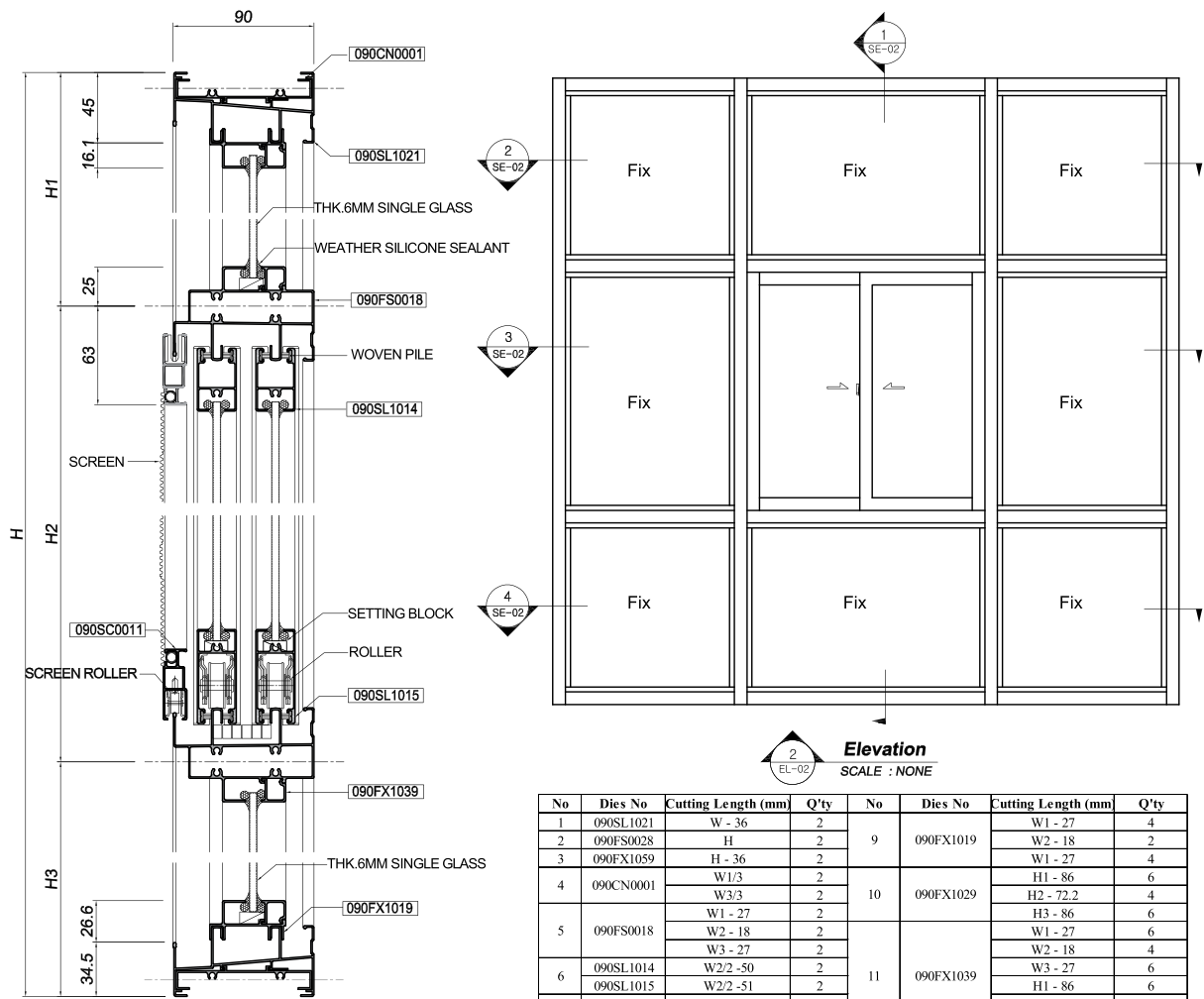

| No | Dies No   | Cutting Length (mm) | Q'ty | No | Dies No   | Cutting Length (mm) | Q'ty |
|----|-----------|---------------------|------|----|-----------|---------------------|------|
| 1  | 090SL1021 | W - 36              | 2    | 9  | 090FX1019 | W1 - 27             | 4    |
| 2  | 090FS0028 | H                   | 2    |    |           | W2 - 18             | 2    |
| 3  | 090FX1059 | H - 36              | 2    |    |           | W1 - 27             | 4    |
| 4  | 090CN0001 | W1/3                | 2    | 10 | 090FX1029 | H1 - 86             | 6    |
|    |           | W3/3                | 2    |    |           | H2 - 72.2           | 4    |
|    |           | W1 - 27             | 2    |    |           | H3 - 86             | 6    |
| 5  | 090FS0018 | W2 - 18             | 2    |    |           | W1 - 27             | 6    |
|    |           | W3 - 27             | 2    |    |           | W2 - 18             | 4    |
| 6  | 090SL1014 | W2/2 - 50           | 2    | 11 | 090FX1039 | W3 - 27             | 6    |
|    | 090SL1015 | W2/2 - 51           | 2    |    |           | H1 - 86             | 6    |
| 7  | 090SL1016 | H2 - 50             | 2    |    |           | H2 - 72.2           | 4    |
| 8  | 090SL1017 | H2 - 50             | 2    |    |           | H3 - 86             | 6    |
|    |           |                     |      | 12 | 090SC0011 | W2 / 2              | 2    |
|    |           |                     |      |    |           | H2 - 45             | 1    |
|    |           |                     |      | 13 | 090SC0013 | H2 - 45             | 1    |

**1 Vertical Section Detail**  
SCALE : NONE

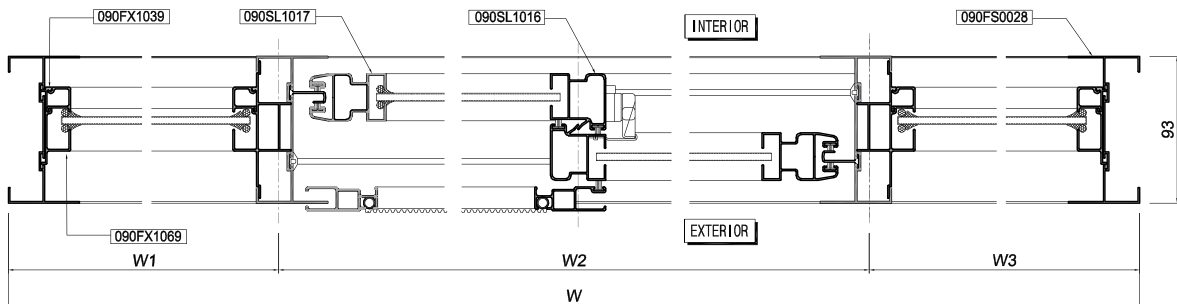

**3 Horizontal Section Detail**  
SCALE : NONE

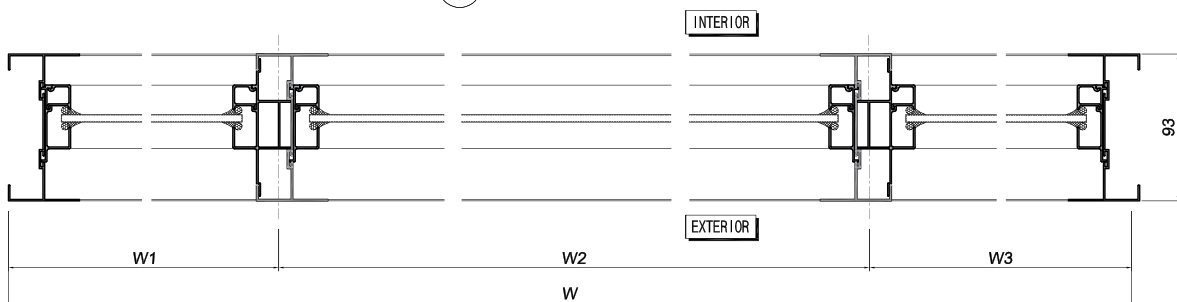

**2,4 Horizontal Section Detail**  
SCALE : NONE

# CỬA TRƯỢT VÀ CỔ ĐỊNH HỆ 90

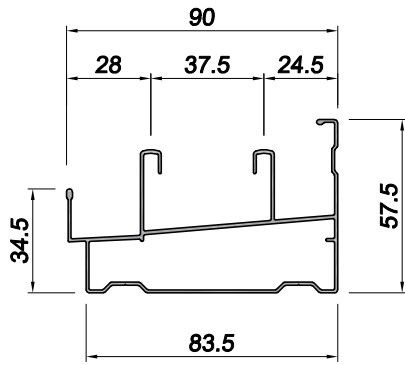

**090SL0011**  
THK. 1.0 mm - 1.021Kg/m

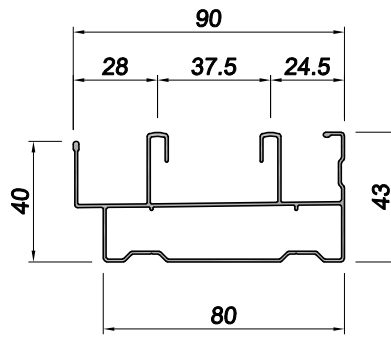

**090SL0012**  
THK. 1.0 mm - 0.927Kg/m

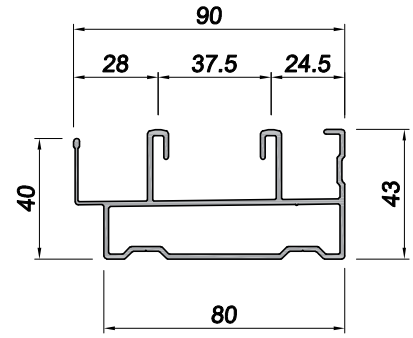

**090SL012A**  
THK. 1.6 mm - 1.426Kg/m

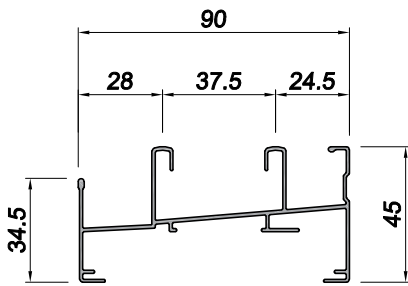

**090SL1021**  
THK. 1.0mm - 0.853 Kg/m

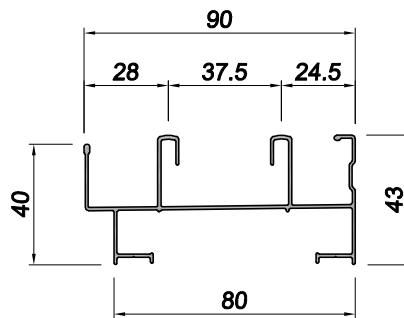

**090SL1001**  
THK. 0.95mm - 0.787 Kg/m

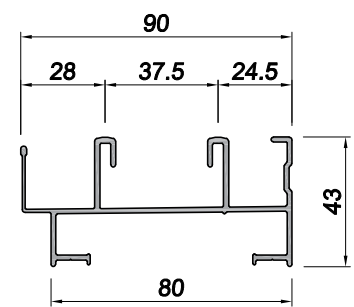

**090SL101A**  
THK. 1.6 mm - 1.163Kg/m

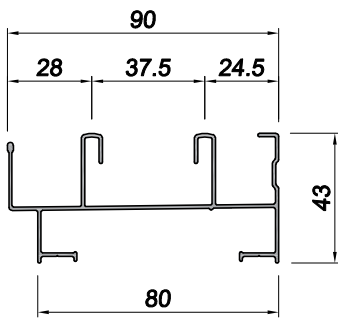

**090SL101B**  
THK. 1.1 mm - 0.833Kg/m

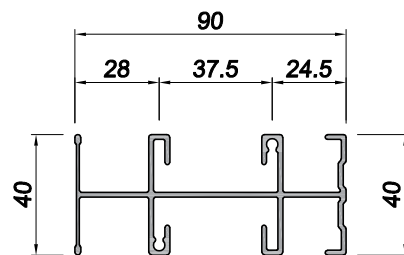

**090SL0018**  
THK. 1.6 mm - 1.306Kg/m

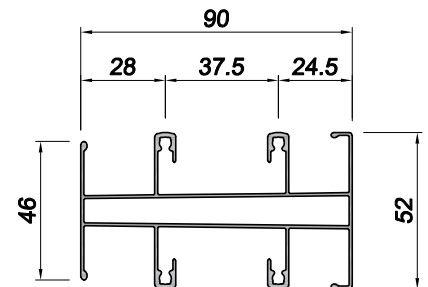

**090SL0021**  
THK. 1.0 mm - 1.270Kg/m

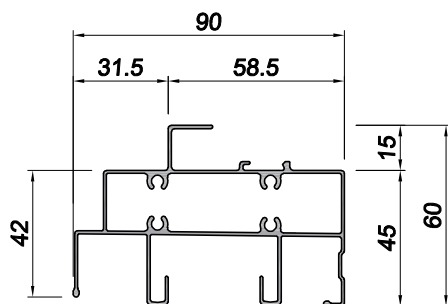

**090FS0018**  
THK. 1.0 mm - 1.245 Kg/m

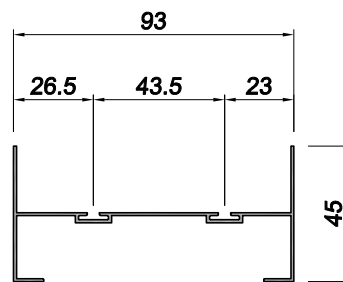

**090FS0028**  
THK. 1.0mm - 0.598 Kg/m

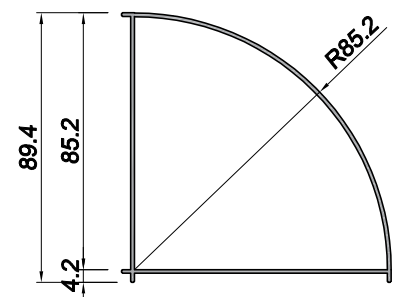

**090CR0001**  
THK. 1.2mm - 1.029 Kg/m



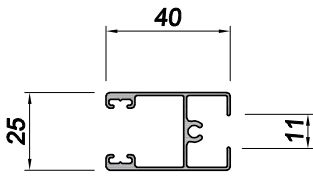

**090SL1014**  
THK. 1.0 mm - 0.467 Kg/m

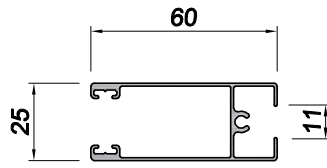

**090SL1015**  
THK. 1.0 mm - 0.575 Kg/m

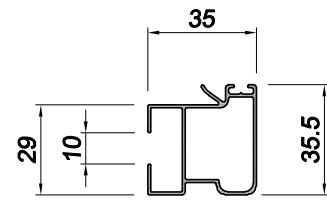

**090SL1016**  
THK.0.95mm - 0.418 Kg/m

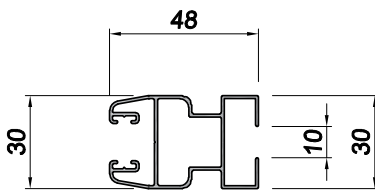

**090SL1017**  
THK.0.95mm - 0.567 Kg/m

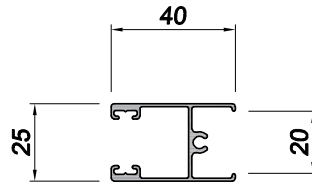

**090SL2014**  
THK. 1.0 mm - 0.440 Kg/m

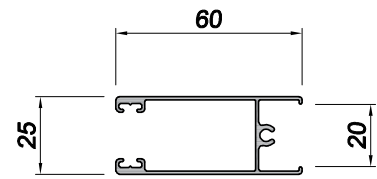

**090SL2015**  
THK. 1.0 mm - 0.548 Kg/m

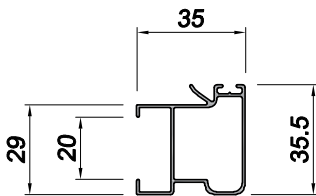

**090SL2016**  
THK.0.9mm - 0.393 Kg/m

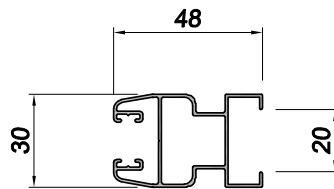

**090SL2017**  
THK.0.95mm - 0.541 Kg/m

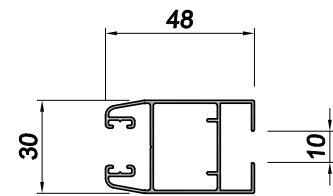

**090SL1027**  
THK. 1.0 mm - 0.557 Kg/m

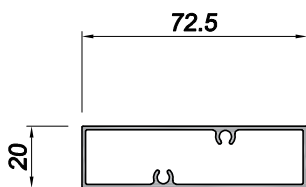

**090FX0018**  
THK. 1.2mm - 0.512 Kg/m

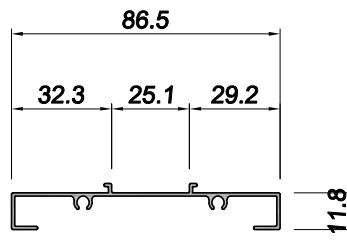

**090CN0001**  
THK. 1.0mm - 0.416 Kg/m

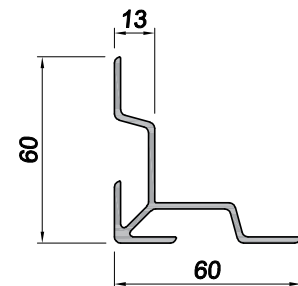

**060CP0013**  
THK. 2.0mm - 0.882 Kg/m

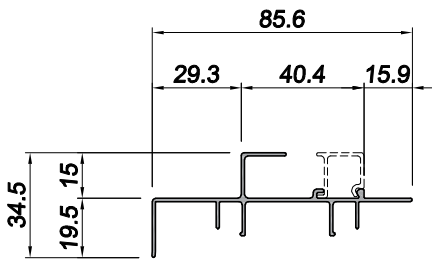

**090FX0089**  
THK. 1.1mm - 0.538 Kg/m

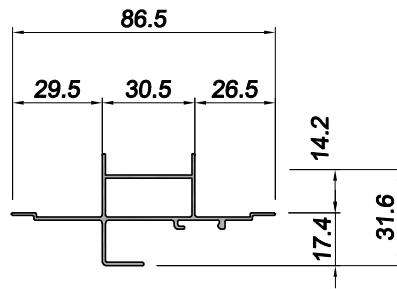

**090FX1059**  
THK. 1.0mm - 0.513 Kg/m

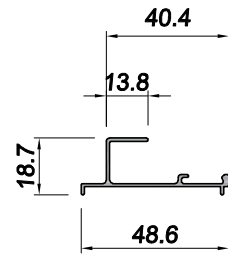

**090FX1069**  
THK. 1.0mm - 0.261 Kg/m

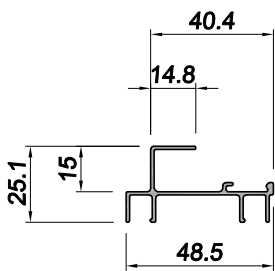

**090FX1019**  
THK. 1.1mm - 0.375 Kg/m

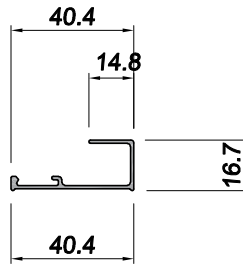

**090FX1029**  
THK.1.1mm - 0.241 Kg/m

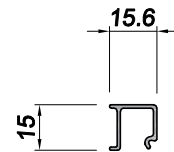

**090FX1039**  
THK.1.1mm - 0.145 Kg/m

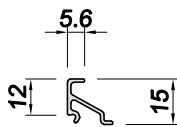

(G :20mm)  
**090FX1049**  
THK. 1.1mm - 0.124Kg/m

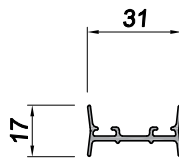

**090SL0017**  
THK. 1.0mm - 0.246 Kg/m

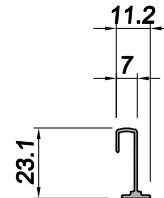

**090FS0038**  
THK. 1.0mm - 0.124 Kg/m

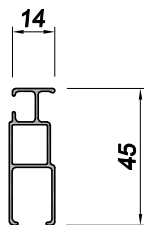

**090SC0011**  
THK. 1.0mm - 0.328 Kg/m

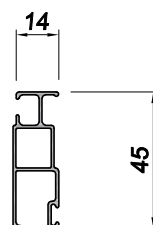

**090SC0013**  
THK.1.0mm - 0.343Kg/m



CỬA TRƯỢT HỆ 110mm



CỬA TRƯỢT VÀ CỐ ĐỊNH HỆ 110mm

### Đặc tính

- Đây là hệ cửa trượt khổ lớn, mang đến sự vững chắc cho căn nhà của bạn. Phù hợp cho cửa ở Balcony, ngăn chia các phòng.
- Màu sắc đa dạng (Sơn tĩnh điện, PVDF, vân gỗ, Anodized...), có thể đáp ứng những yêu cầu khắt khe nhất của từng hạng mục công trình

### Mặt đứng

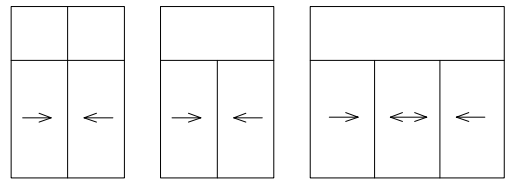
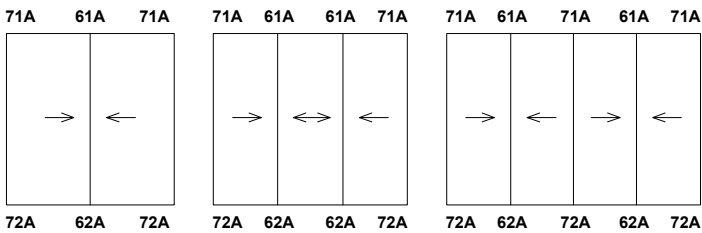

### Phụ kiện



# CỬA TRƯỢT VÀ CỐ ĐỊNH HỆ 110

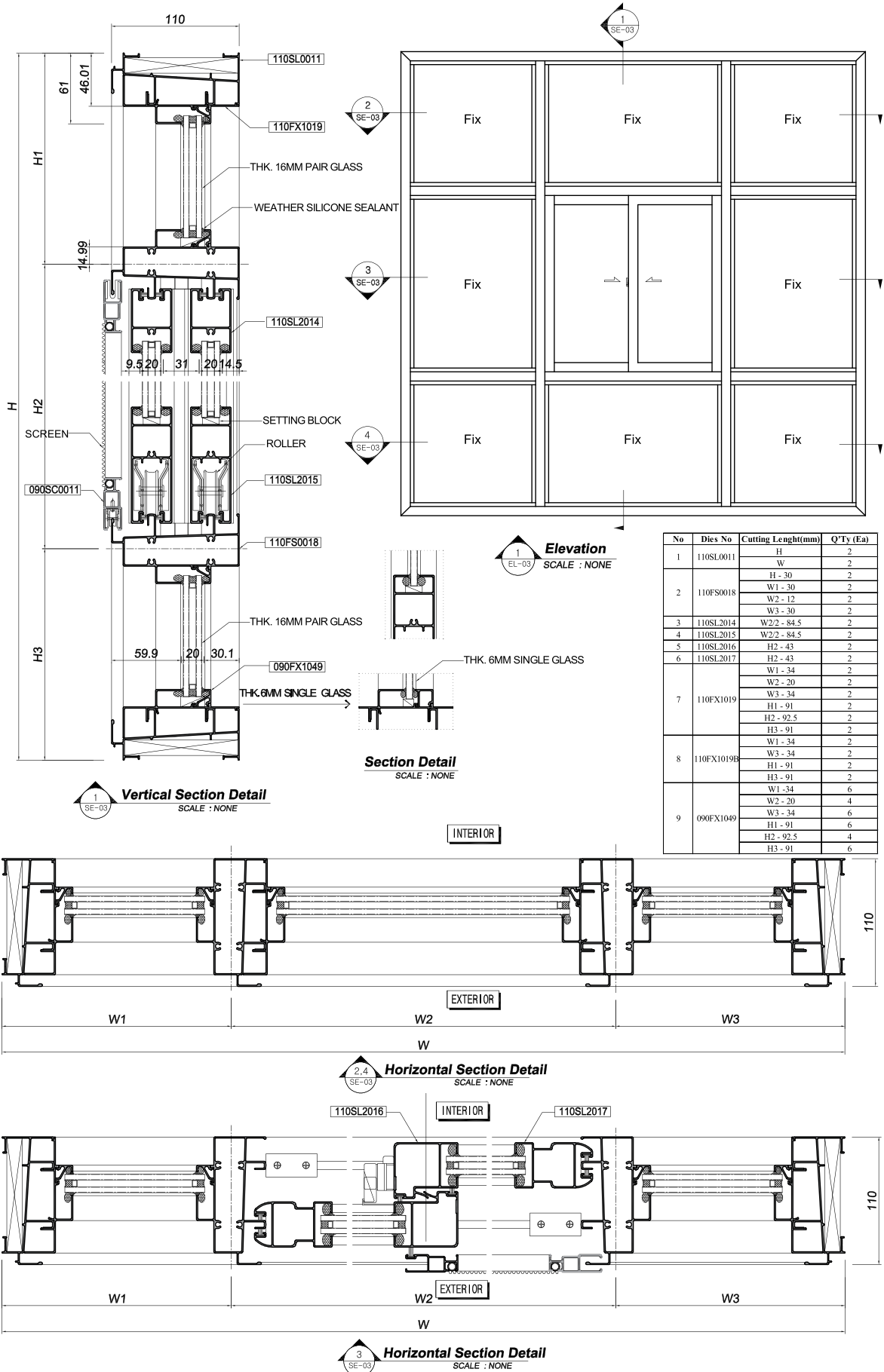



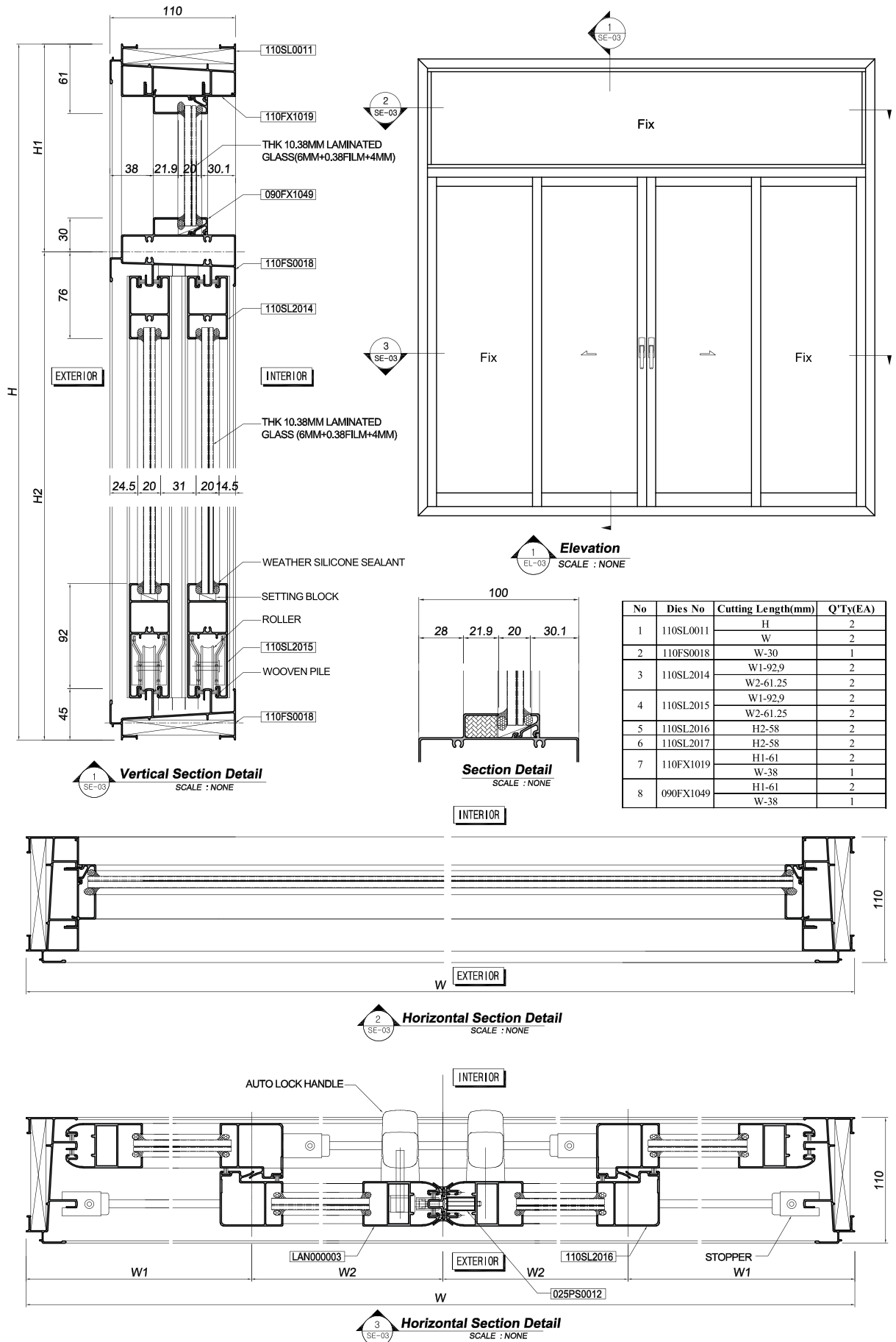

# CỬA TRƯỢT VÀ CỐ ĐỊNH HỆ 110

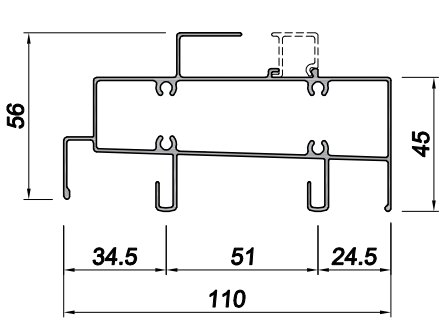

**110FS0018**  
THK. 1.0mm - 1.367 Kg/m

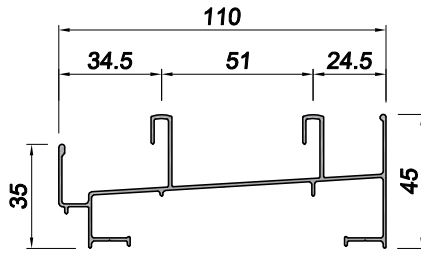

**110SL0011**  
THK. 1.0mm - 0.898 Kg/m

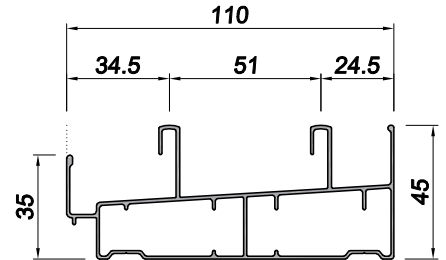

**110SL0021**  
THK. 1.0mm - 1.186 Kg/m

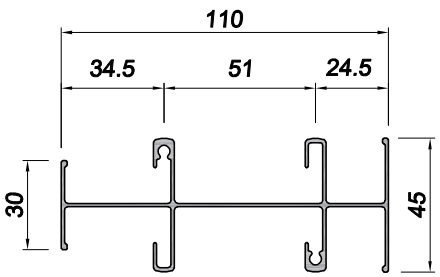

**110SL0018**  
THK. 1.1mm - 1.071 Kg/m

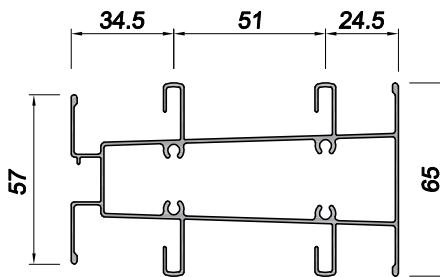

**110SL0028**  
THK. 1.1mm - 1.624 Kg/m

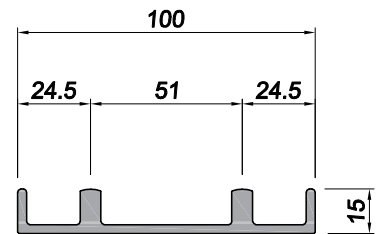

**110SL0002**  
THK. 3.0mm - 1.456 Kg/m

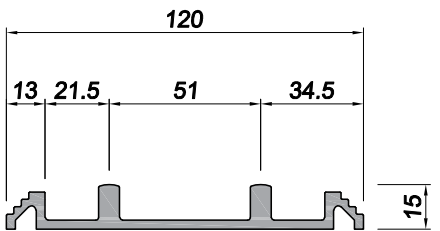

**110SL002A**  
THK. 3.0mm - 1.661 Kg/m

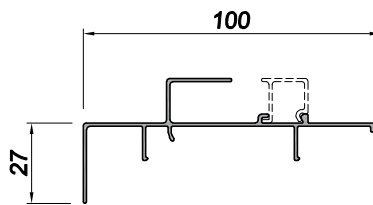

**110FX1019**  
THK. 1.1mm - 0.607 Kg/m

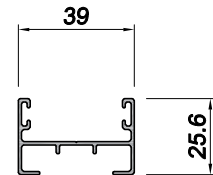

**110SL0048**  
THK. 1.1mm - 0.375 Kg/m

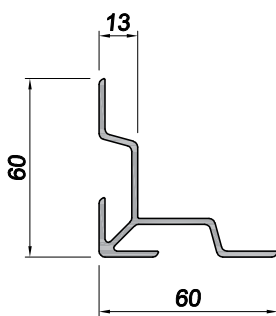

**060CP0013**  
THK. 2.0mm - 0.882 Kg/m

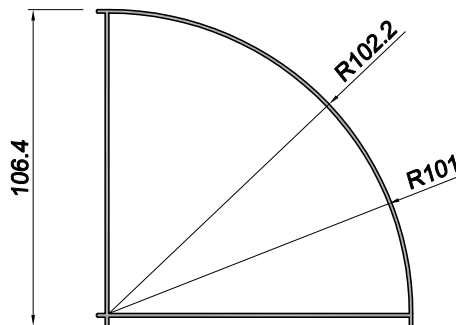

**110CR0001**  
THK. 1.2mm - 1.226 Kg/m

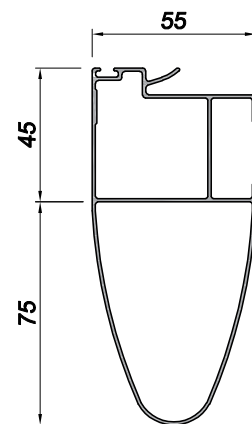

**MP000001A**  
THK. 1.1 mm - 1.201 Kg/m

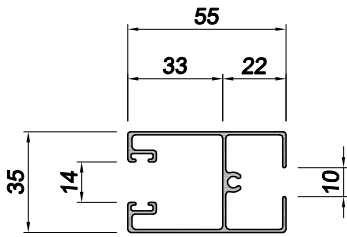

**110SL1014**  
THK. 1.1mm - 0.689 Kg/m

**110SL1014B**  
THK. 1.2mm - 0.738 Kg/m

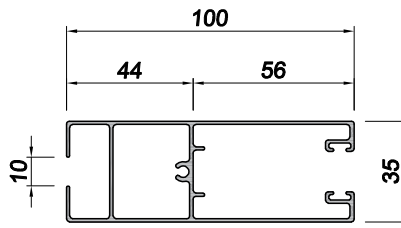

**110SL1015**  
THK. 1.0mm - 1.112 Kg/m

**110SL1015B**  
THK. 1.2mm - 1.176 Kg/m

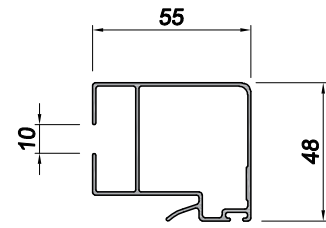

**110SL1016**  
THK. 1.0mm - 0.755 Kg/m

**110SL1016B**  
THK. 1.2mm - 0.843 Kg/m

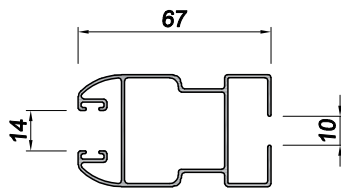

**110SL1017**  
THK. 1.1mm - 0.856 Kg/m

**110SL1017B**  
THK. 1.2mm - 0.927 Kg/m

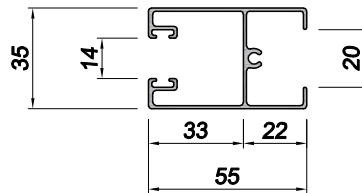

**110SL2014**  
THK. 1.1mm - 0.677 Kg/m

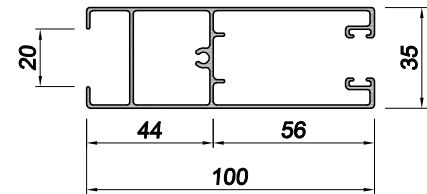

**110SL2015**  
THK. 1.0mm - 1.082 Kg/m

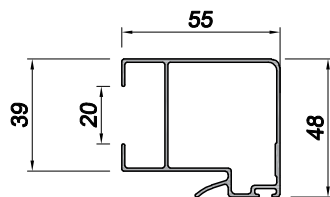

**110SL2016**  
THK. 1.0mm - 0.725 Kg/m

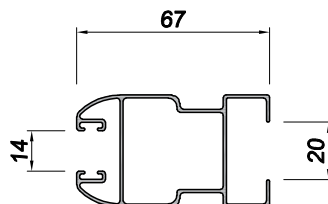

**110SL2017**  
THK. 1.1mm - 0.826 Kg/m

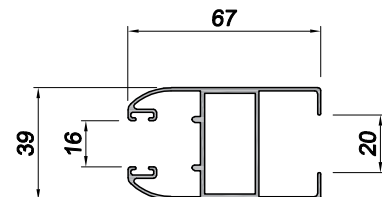

**LAN000003**  
THK. 1.2mm - 0.960 Kg/m

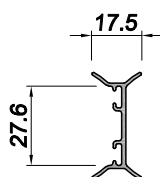

**110SL0038**  
THK. 1.5mm - 0.257 Kg/m

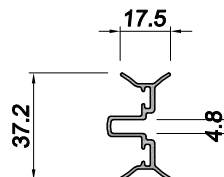

**LAN000004**  
THK. 1.15mm - 0.332 Kg/m

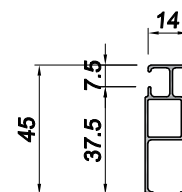

**090SC0011**  
THK. 0.95mm - 0.328 Kg/m

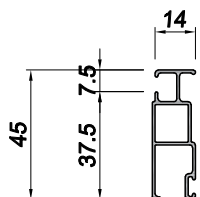

**090SC0013**  
THK. 0.95mm - 0.343 Kg/m

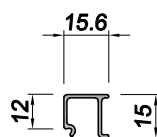

(G :10mm)  
**090FX1039**  
THK. 1.1mm - 0.145 Kg/m

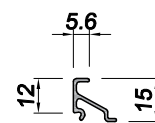

(G :20mm)  
**090FX1049**  
THK. 1.1mm - 0.124 Kg/m

# CỬA TRƯỢT VÀ CỐ ĐỊNH HỆ HD93

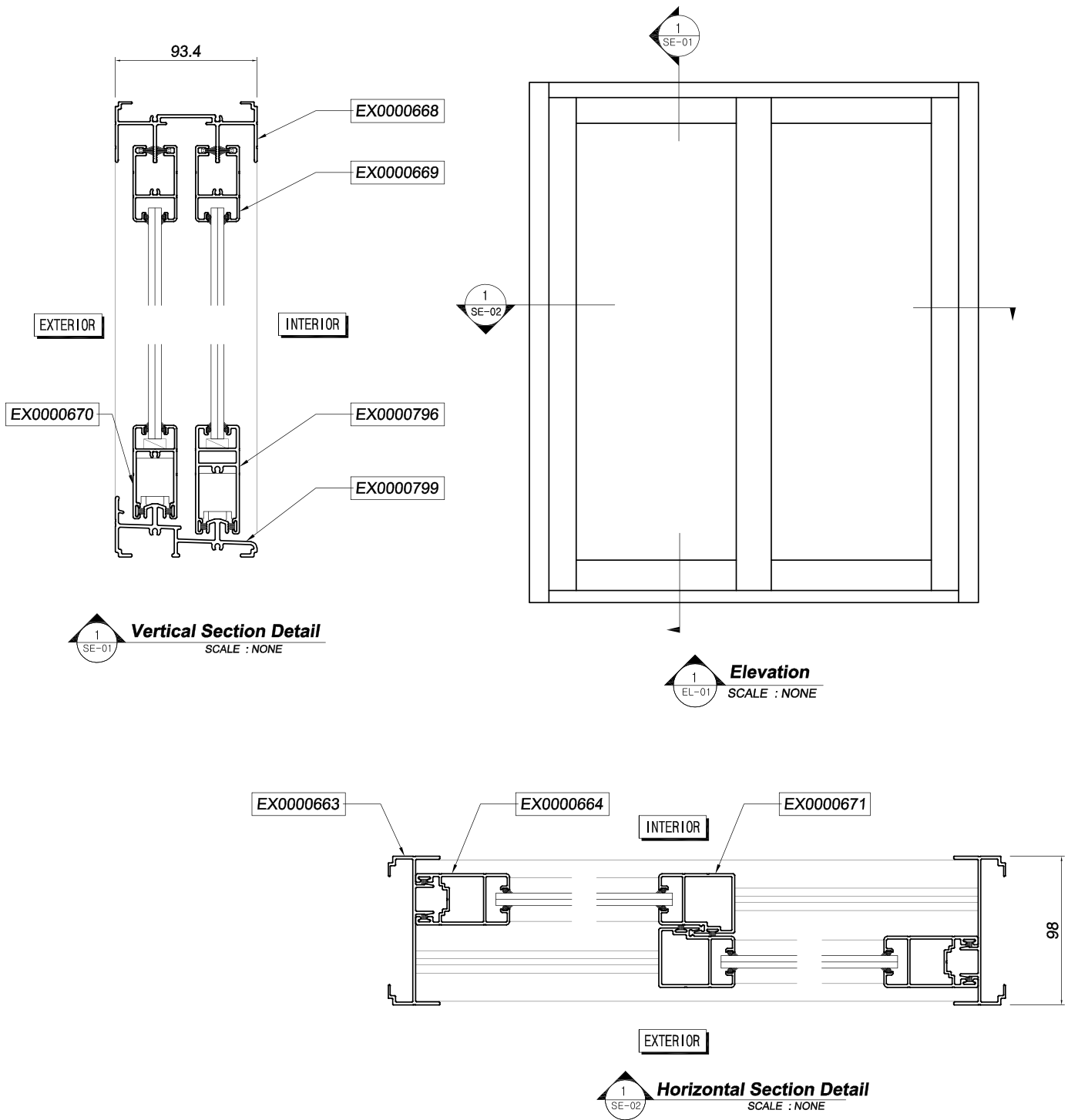

## Phụ kiện:





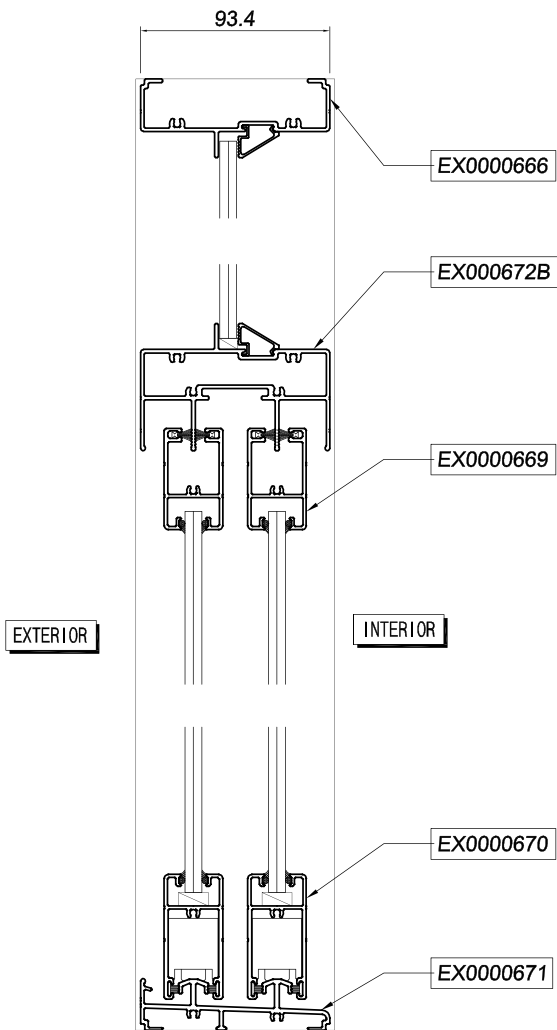

**Vertical Section Detail**  
SCALE : NONE

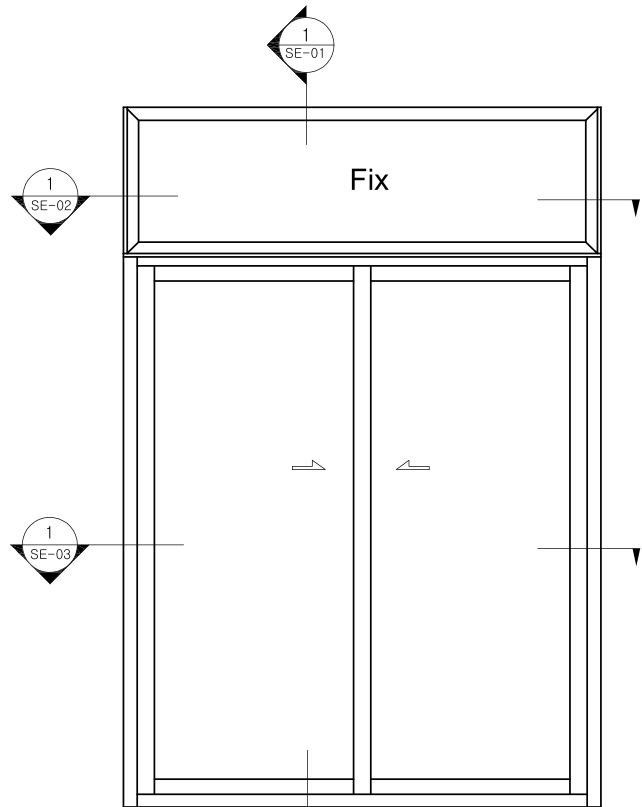

**Elevation**  
SCALE : NONE

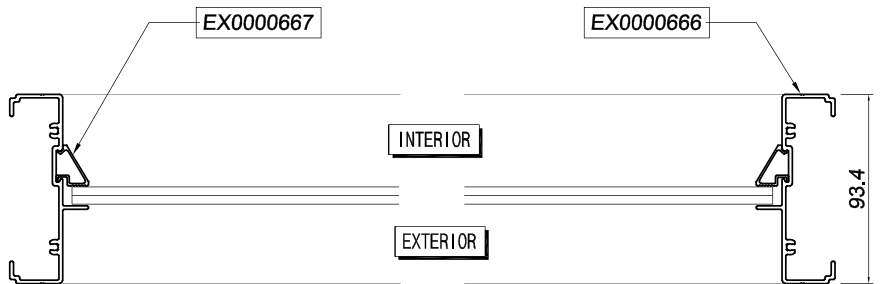

**Horizontal Section Detail**  
SCALE : NONE

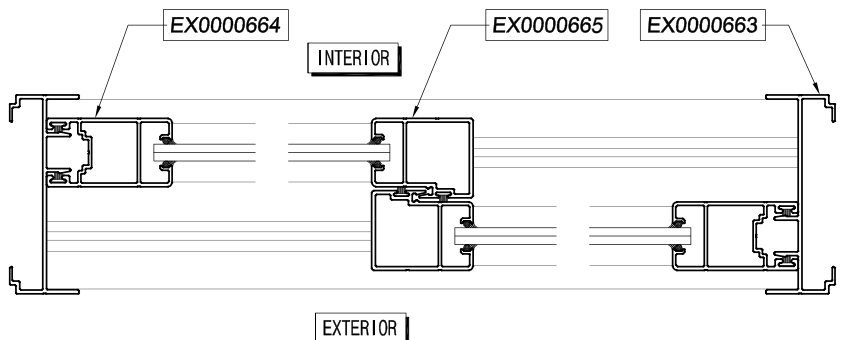

**Horizontal Section Detail**  
SCALE : NONE

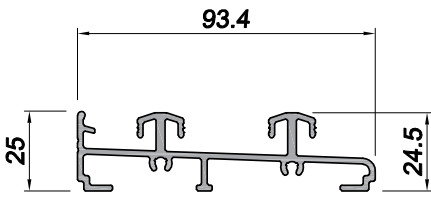

**EX0000671 (D1942A)**  
THK. 1.8 mm - 1.258 Kg/m

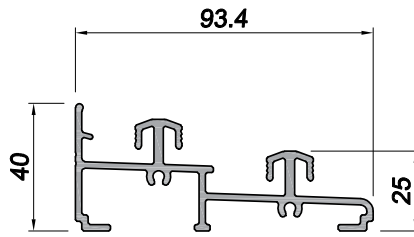

**EX0000799 (D1942)**  
THK. 2.0 mm - 1.570 Kg/m

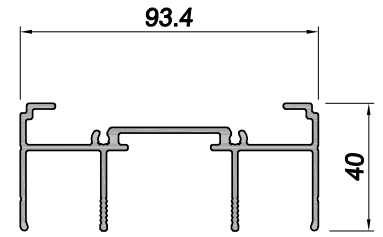

**EX0000668 (D1541A)**  
THK. 1.8 mm - 1.342 Kg/m

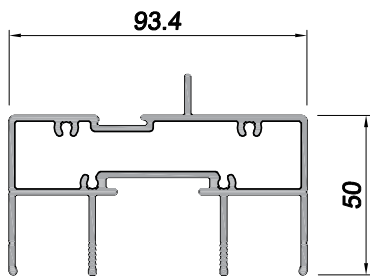

**EX000672B (D1551A)**  
THK. 1.8 mm - 1.988 Kg/m

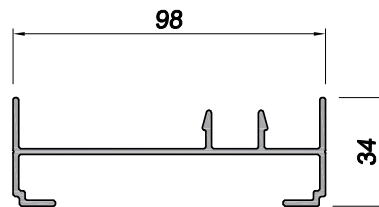

**EX0000663 (D1543A)**  
THK. 1.8 mm - 1.035 Kg/m

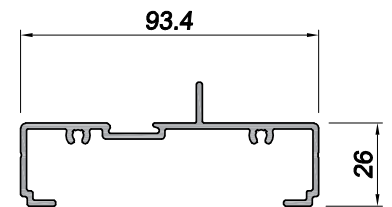

**EX0000666 (D1559A)**  
THK. 1.8 mm - 0.989 Kg/m

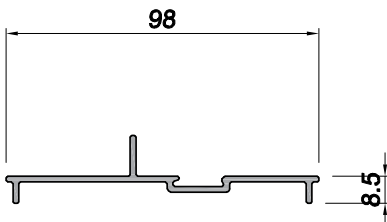

**EX0000672 (D1549A)**  
THK. 1.8 mm - 0.646 Kg/m

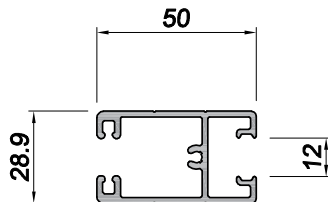

**EX0000669 (D1544A)**  
THK. 1.8 mm - 0.926 Kg/m

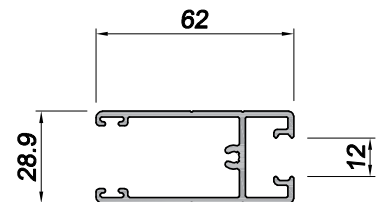

**EX0000670 (D1555)**  
THK. 1.8 mm - 0.935 Kg/m

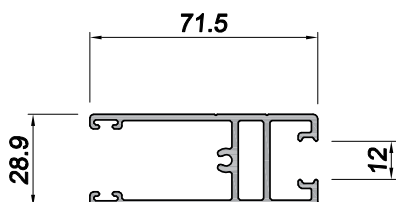

**EX0000796 (D1555A)**  
THK. 2.0 mm - 1.248 Kg/m

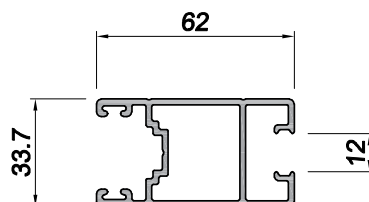

**EX0000664 (D1546)**  
THK. 1.8 mm - 1.184 Kg/m

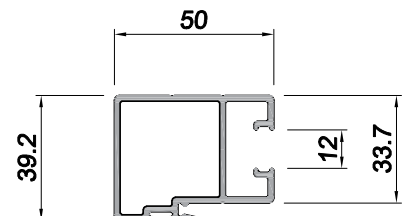

**EX0000665 (D1547A)**  
THK. 1.8 mm - 1.009 Kg/m

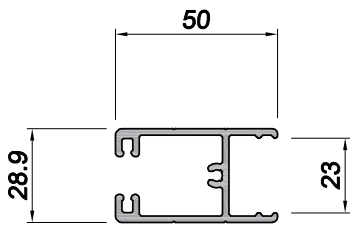

**EX0000800 (D1554A)**  
THK. 2.0 mm - 0.904 Kg/m

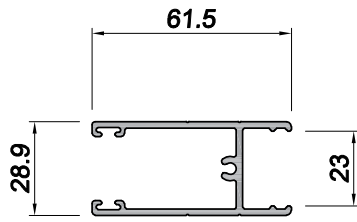

**EX0000798 (D1565A)**  
THK. 2.0 mm - 0.914 Kg/m

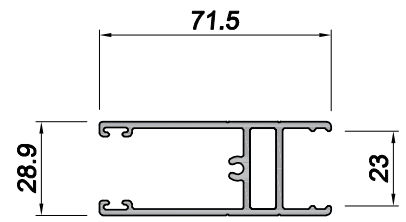

**EX0000797 (D1585A)**  
THK. 2.0 mm - 1.158 Kg/m

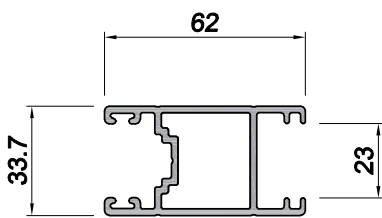

**EX0000802 (D1556A)**  
THK. 2.0 mm - 1.201 Kg/m

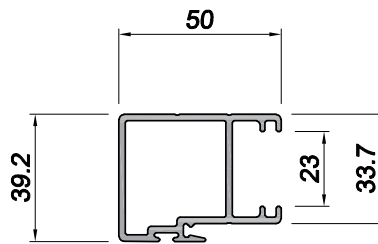

**EX0000801 (D1557A)**  
THK. 2.0 mm - 1.025 Kg/m

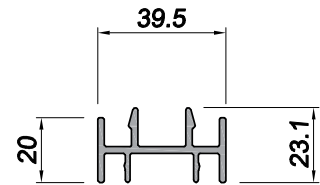

**EX0000673 (D1548A)**  
THK. 2.0 mm - 0.622 Kg/m

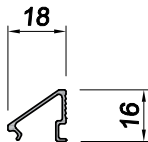

**EX0000667 (C101A)**  
THK. 0.9 mm - 0.124 Kg/m

# CỬA TRƯỢT VÀ CỐ ĐỊNH HỆ HD95

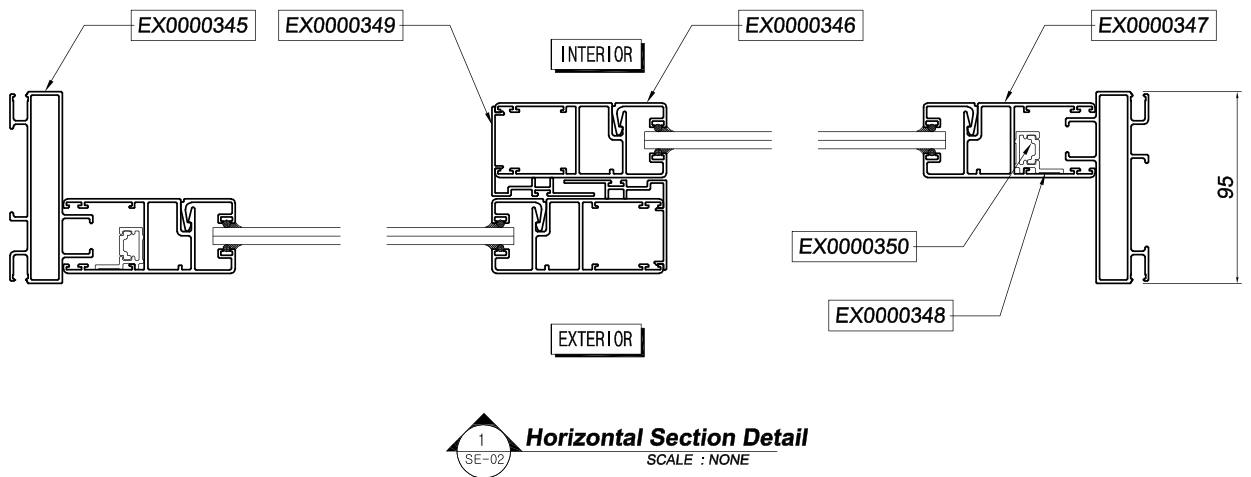
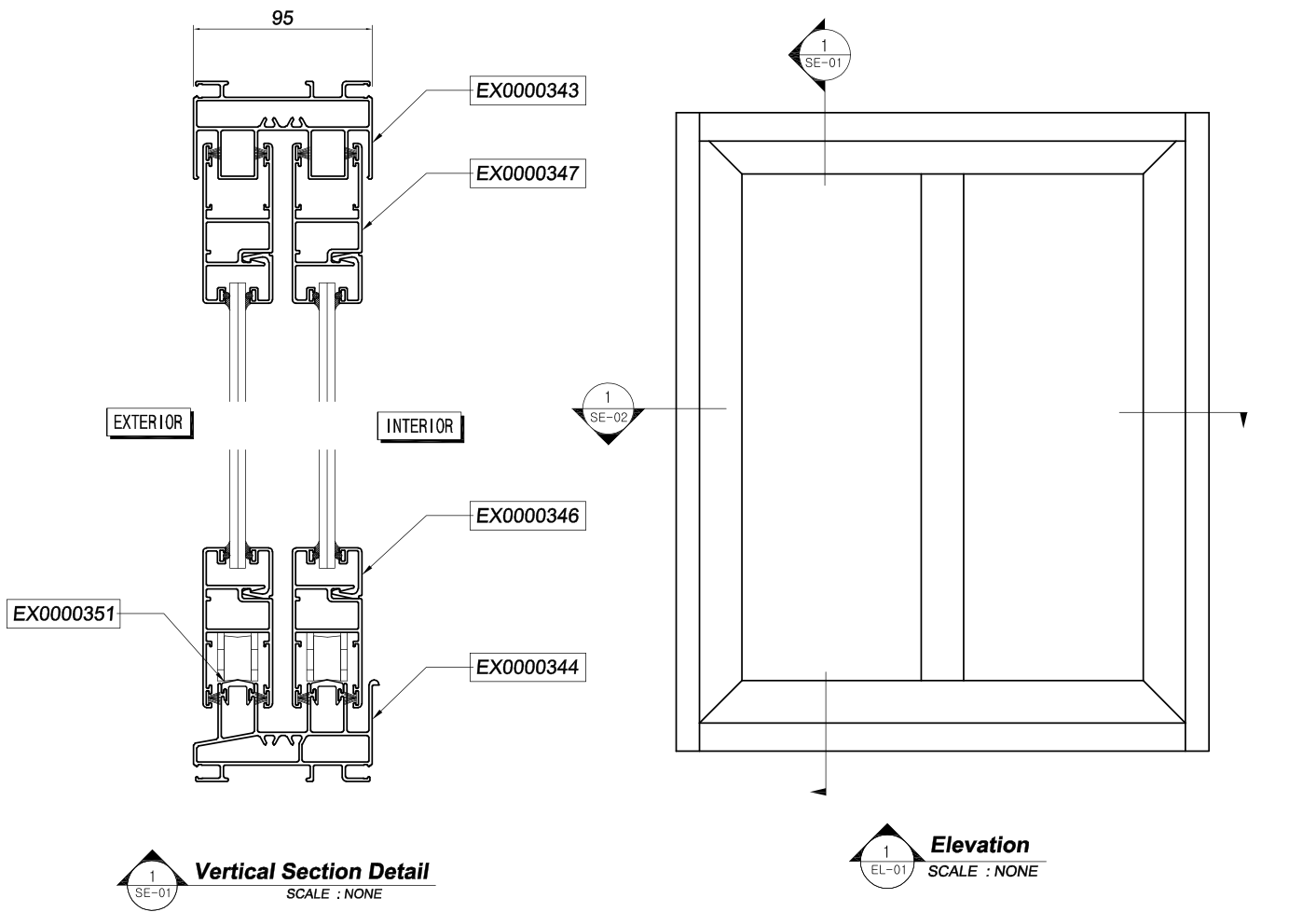

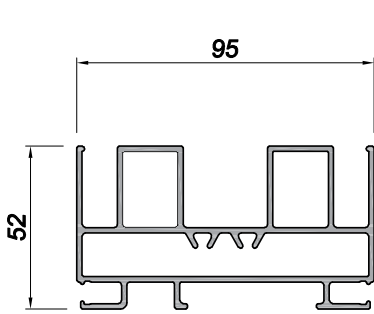

**EX0000343 (D1871)**  
THK. 1.7 mm - 2.231 Kg/m

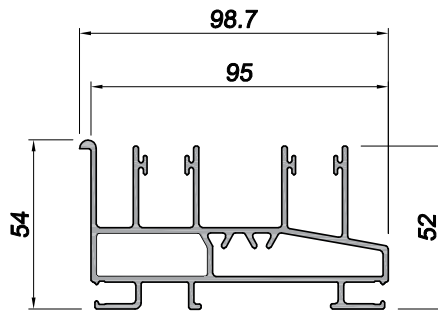

**EX0000344 (D1872)**  
THK. 1.7 mm - 2.151 Kg/m

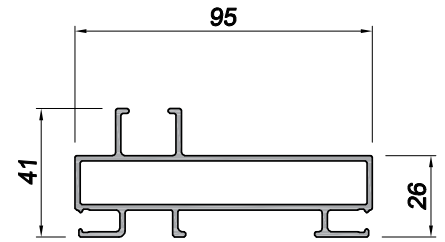

**EX0000345 (D1873)**  
THK. 1.7 mm - 1.432 Kg/m

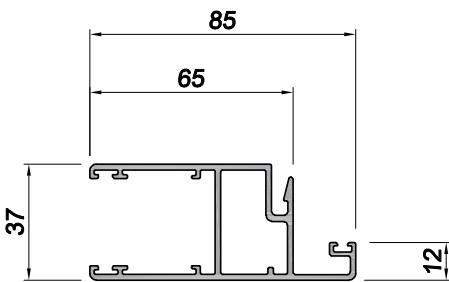

**EX0000347 (D1875A)**  
THK. 1.8 mm - 1.317 Kg/m

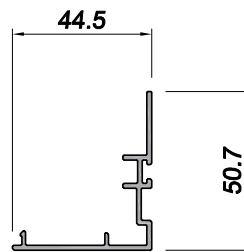

**EX0000349 (D1877)**  
THK. 1.5 mm - 0.497 Kg/m

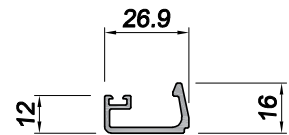

**EX0000346 (D1874A)**  
THK. 1.8 mm - 0.297 Kg/m

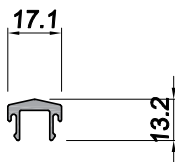

**EX0000351 (D1887)**  
THK. 1.0 mm - 0.209 Kg/m

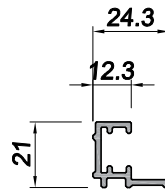

**EX0000348 (D1876)**  
THK. 1.7 mm - 0.301 Kg/m

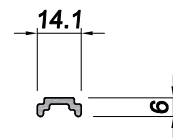

**EX0000350 (D1880)**  
THK. 2.0 mm - 0.114 Kg/m



# CỬA TRƯỢT VÀ CỐ ĐỊNH HỆ HD2600

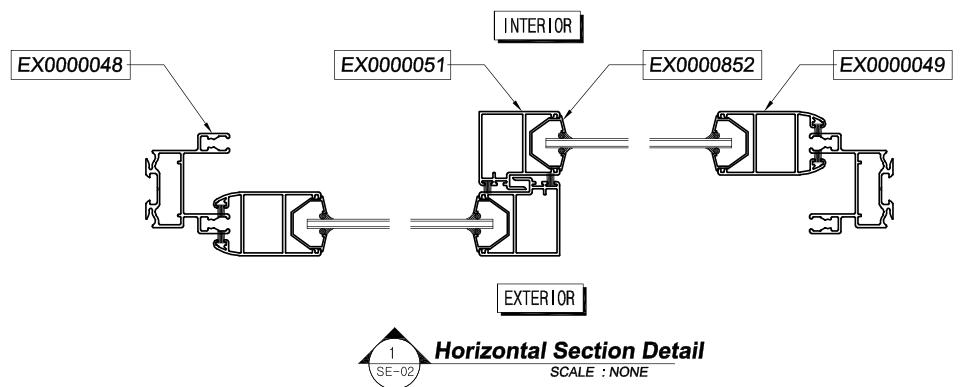
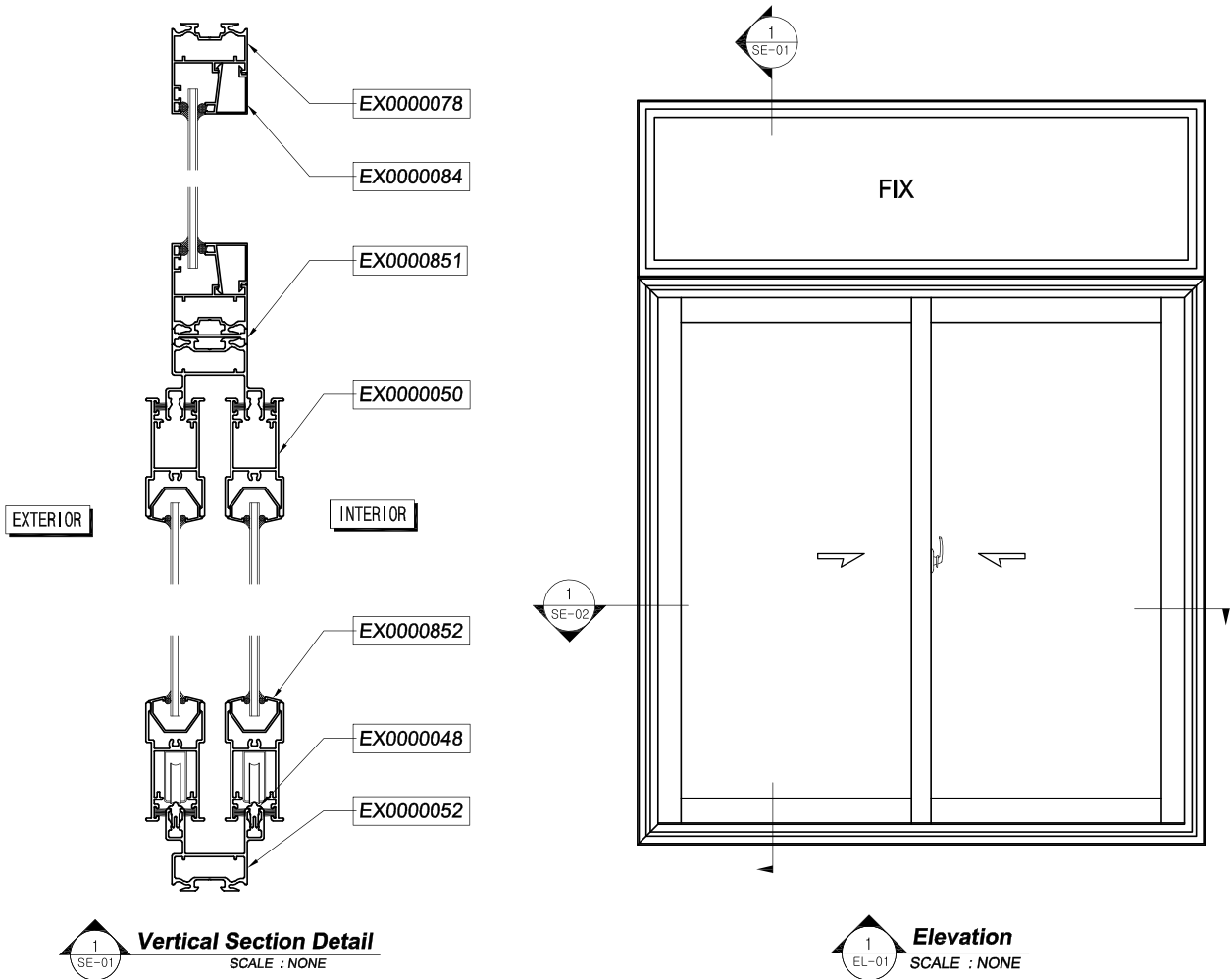

Phụ kiện:



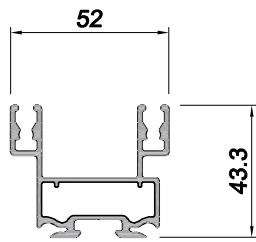

**EX0000052 (2617)**  
THK. 1.4 mm - 0.994 Kg/m

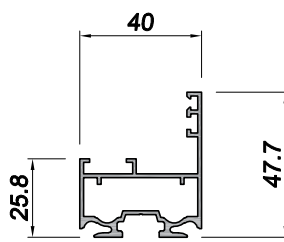

**EX0000078 (4420)**  
THK. 1.25 mm - 0.703 Kg/m

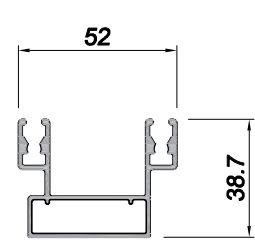

**EX0000083 (2602)**  
THK. 1.2 mm - 0.777 Kg/m

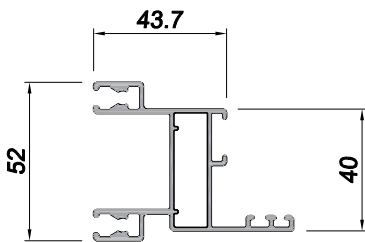

**EX0000082 (2607)**  
THK. 1.2 mm - 0.961 Kg/m

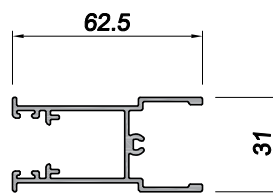

**EX0000050 (2606)**  
THK. 1.4 mm - 0.798 Kg/m

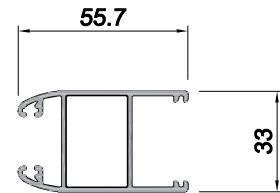

**EX0000049 (2688)**  
THK. 1.4 mm - 0.764 Kg/m

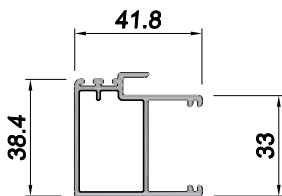

**EX0000051 (2689)**  
THK. 1.4 mm - 0.690 Kg/m

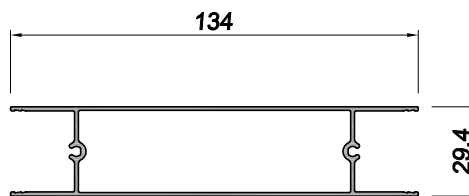

**EX0000110 (2672)**  
THK. 1.2 mm - 1.161 Kg/m

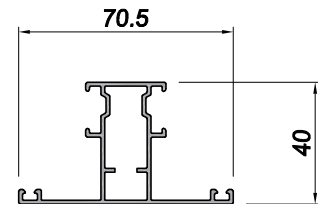

**EX0000085 (4405)**  
THK. 1.25 mm - 0.733 Kg/m

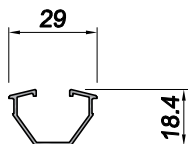

**EX0000852 (26561)**  
THK. 1.0 mm - 0.183 Kg/m

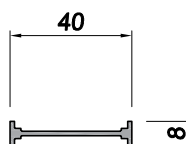

**EX0000851 (433)**  
THK. 1.4 mm - 0.225 Kg/m

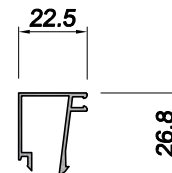

**EX0000084 (5016)**  
THK. 0.9 mm - 0.248 Kg/m

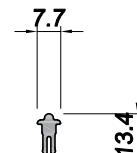

**EX0000048 (3303)**  
THK. 1.4 mm - 0.137 Kg/m



## HỆ CỬA MỞ LẬT

### Đặc tính:

- Là cửa mở lật ra bên ngoài phù hợp với điều kiện thời tiết ở Việt Nam. Với nhiều kích cỡ đa dạng Hệ 38, 70, 80, 100, 120... đây là sản phẩm được lắp ghép dễ dàng dưới dạng tổ hợp với vách cố định, tạo sự độc đáo trong kết cấu kiến trúc.
- Là loại cửa với góc mở cố định rất phù hợp với điều kiện thời tiết nhiều gió ở Việt Nam. Tạo sự an toàn cho ngôi nhà của bạn.
- Có thể dễ dàng kết hợp với hệ chớp, đáp ứng mọi nhu cầu sử dụng của khách hàng.
- Màu sắc đa dạng (Sơn tĩnh điện, PVDF, vân gỗ, Anodized...), có thể đáp ứng những yêu cầu khắt khe nhất của từng hạng mục công trình.

### Mặt đứng

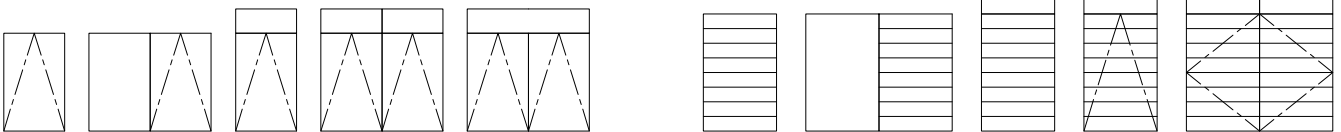

### Phụ kiện



Project Handle



ARM 200



ARM 300

| Stt | Code   | Length(mm) |
|-----|--------|------------|
| 1   | ARM200 | 200        |
| 2   | ARM300 | 300        |
| 3   | ARM400 | 400        |
| 4   | ARM500 | 500        |

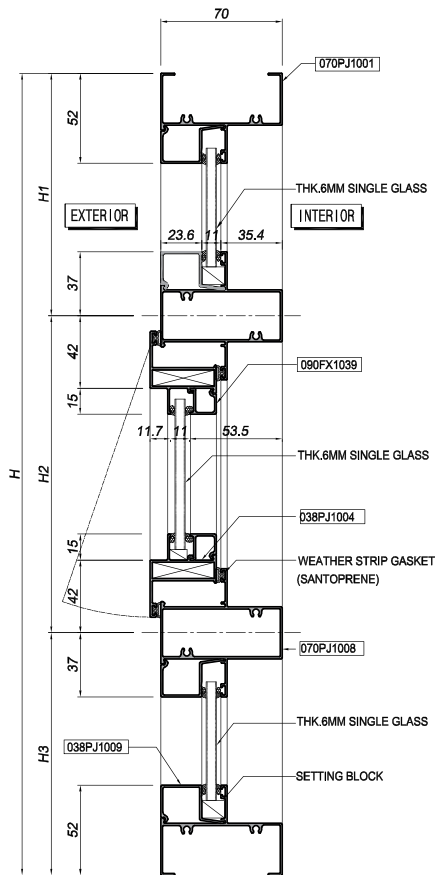

**Vertical Section Detail**  
SCALE : NONE

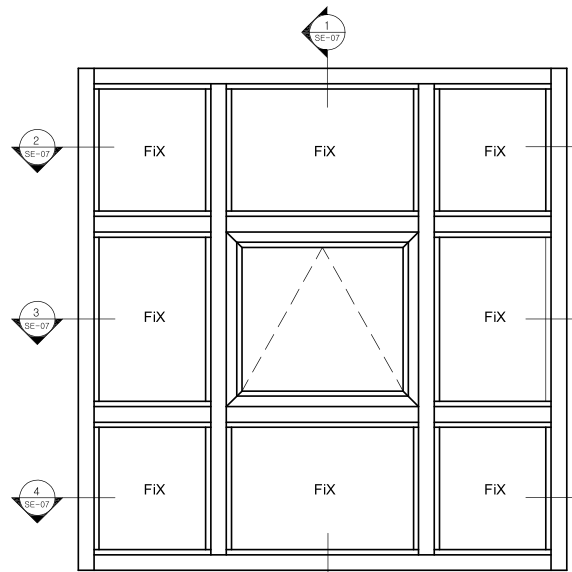

**Elevation (inside)**  
SCALE : NONE

| No | Dies No   | Cutting Length(mm) | Q'Ty (Ea) |
|----|-----------|--------------------|-----------|
| 1  | 070PJ1001 | H                  | 2         |
|    |           | W-60               | 2         |
| 2  | 038PJ1004 | H2 - 18            | 2         |
|    |           | W2 - 18            | 2         |
| 3  | 070PJ1008 | H - 60             | 2         |
|    |           | W1 - 45            | 2         |
|    |           | W2 - 30            | 2         |
| 4  | 038PJ1009 | W3 - 45            | 2         |
|    |           | W1 - 45            | 6         |
|    |           | W2 - 30            | 4         |
|    |           | W3 - 45            | 6         |
|    |           | H1 - 89            | 6         |
|    |           | H2 - 74            | 4         |
| 5  | 090FX1039 | H3 - 89            | 6         |
|    |           | W2 - 84            | 2         |
|    |           | H2 - 114           | 2         |

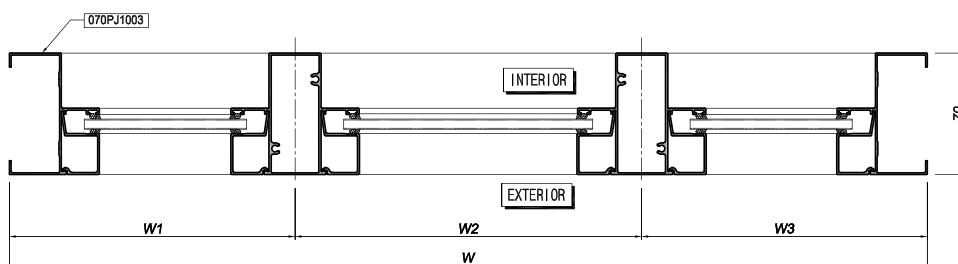

**Horizontal Section Detail 2.4**  
SCALE : NONE

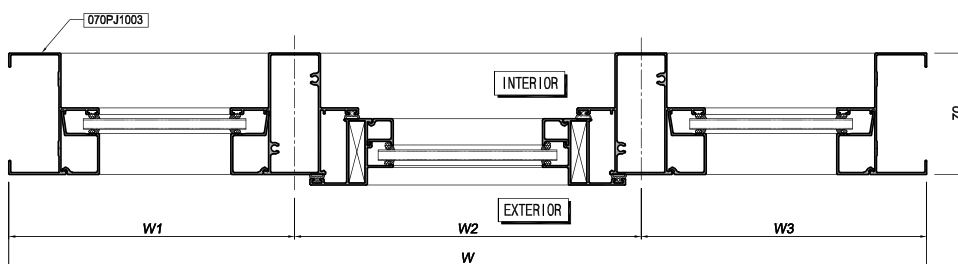

**Horizontal Section Detail 3**  
SCALE : NONE

# CỬA LẬT VÀ CỐ ĐỊNH KẾT HỢP CHỚP HỆ 70

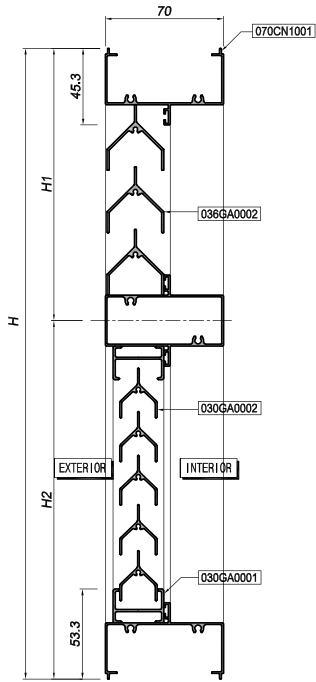

**Vertical Section Detail**  
SCALE : NONE

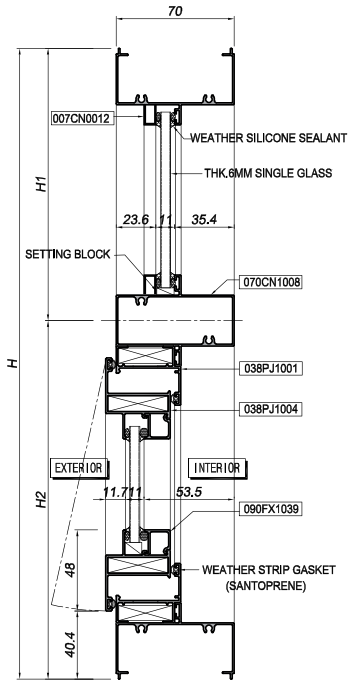

**Vertical Section Detail**  
SCALE : NONE

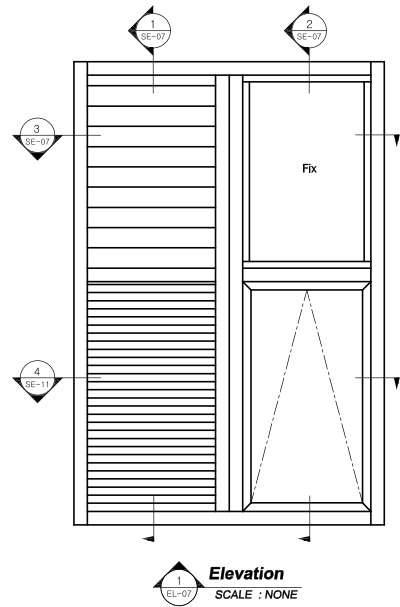

**Elevation**  
SCALE : NONE

| No | Dies No   | Cutting Length(mm) | Q'Ty (Ea) |
|----|-----------|--------------------|-----------|
| 1  | 070CN1001 | W-60               | 2         |
|    |           | H-60               | 1         |
| 2  | 070CN1003 | H                  | 2         |
|    |           | H-60               | 1         |
| 3  | 070CN1008 | W1-60              | 1         |
|    |           | W2-60              | 1         |
| 4  | 090CN0012 | W2-60              | 2         |
|    |           | H1-70              | 2         |
| 5  | 038PJ1001 | W2-60              | 2         |
|    |           | H2-60              | 2         |
| 6  | 038PJ1004 | W2-75              | 2         |
|    |           | H2-75              | 2         |
| 7  | 090FX1039 | W2-141             | 2         |
|    |           | H2-171             | 2         |
| 8  | 036GA0002 | W1-60              | x         |
| 9  | 030GA0001 | W1-60              | 2         |
| 10 | 030GA0002 | W1-60              | x         |

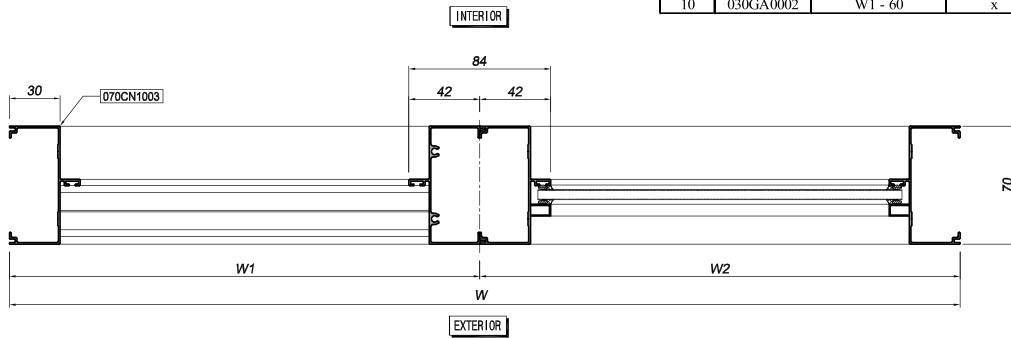

**Horizontal Section Detail**  
SCALE : NONE

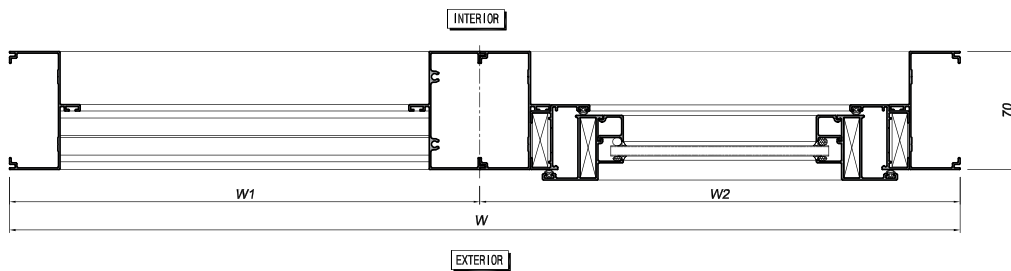

**Horizontal Section Detail**  
SCALE : NONE



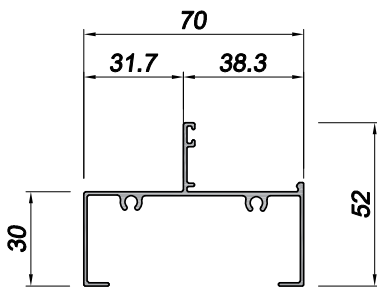

**070PJ1001**  
THK. 1.2 mm - 0.626 Kg/m

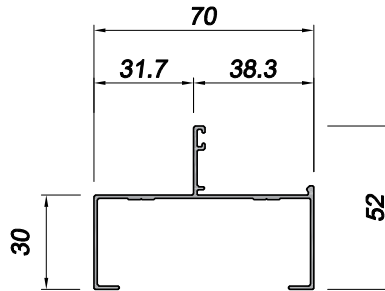

**070PJ1003**  
THK. 1.0 mm - 0.516 Kg/m

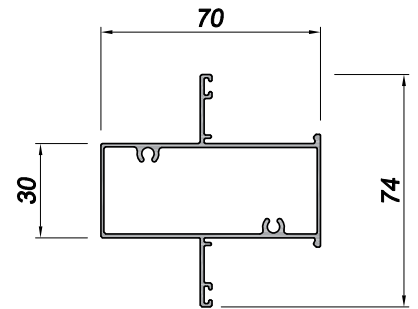

**070PJ1008**  
THK. 1.2 mm - 0.923 Kg/m

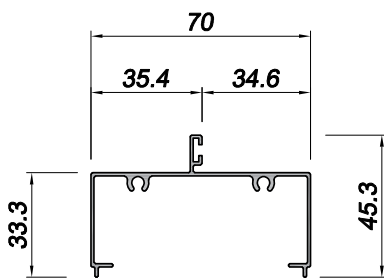

**070CN1001**  
THK. 1.0 mm - 0.549 Kg/m

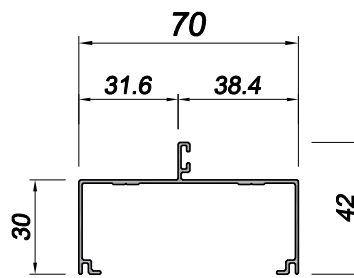

**070CN1003**  
THK. 1.0 mm - 0.474 Kg/m

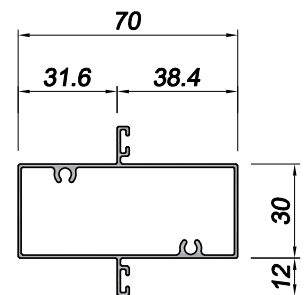

**070CN1008**  
THK. 1.0 mm - 0.742 Kg/m

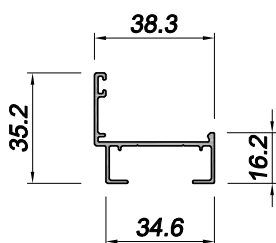

**038PJ1001**  
THK. 1.2 mm - 0.337 Kg/m

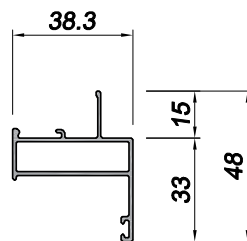

**038PJ1004**  
THK. 1.2 mm - 0.477 Kg/m

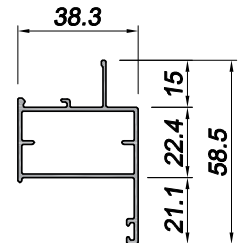

**038PJ1014**  
THK. 1.2 mm - 0.571 Kg/m

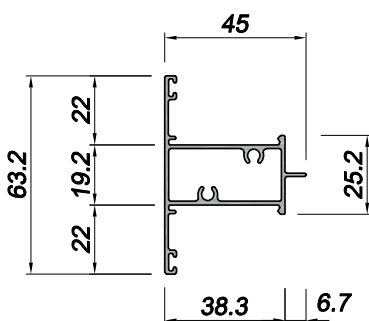

**038PJ1008**  
THK. 1.2 mm - 0.672 Kg/m

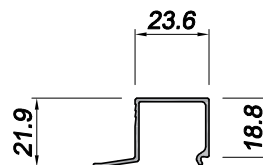

**038PJ1009**  
THK. 1.1 mm - 0.241 Kg/m

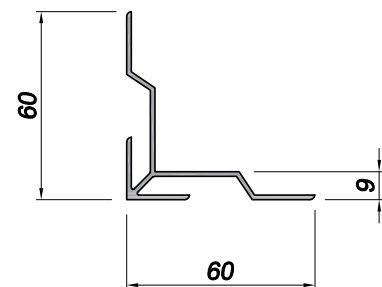

**060CP0009**  
THK. 1.5 mm - 0.641 Kg/m

# CỬA MỞ LẬT VÀ CỐ ĐỊNH HỆ 70

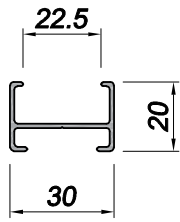

**030GA0001**  
THK. 1.2 mm - 0.262 Kg/m

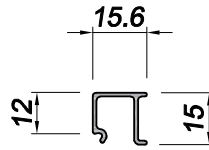

(G : 10mm)  
**090FX1039**  
THK. 1.1 mm - 0.145 Kg/m

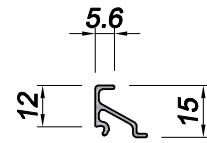

(G : 20mm)  
**090FX1049**  
THK. 1.1 mm - 0.124 Kg/m

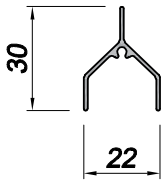

**030GA0002**  
THK. 1.1 mm - 0.190 Kg/m

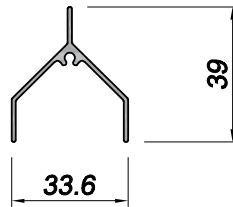

**036GA0002**  
THK. 1.2 mm - 0.298 Kg/m

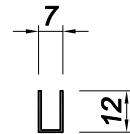

**007CN0012**  
THK. 0.7mm - 0.056 Kg/m

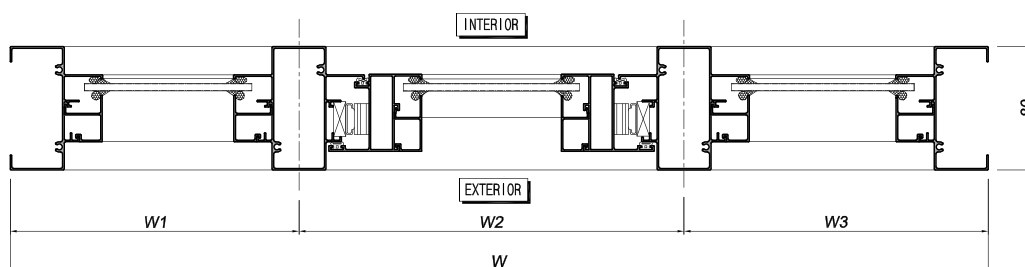
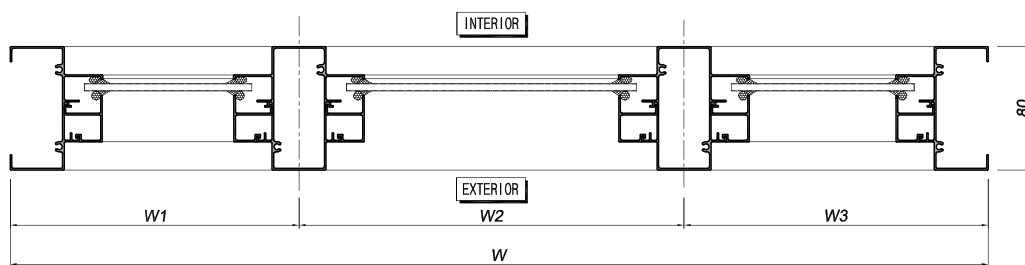
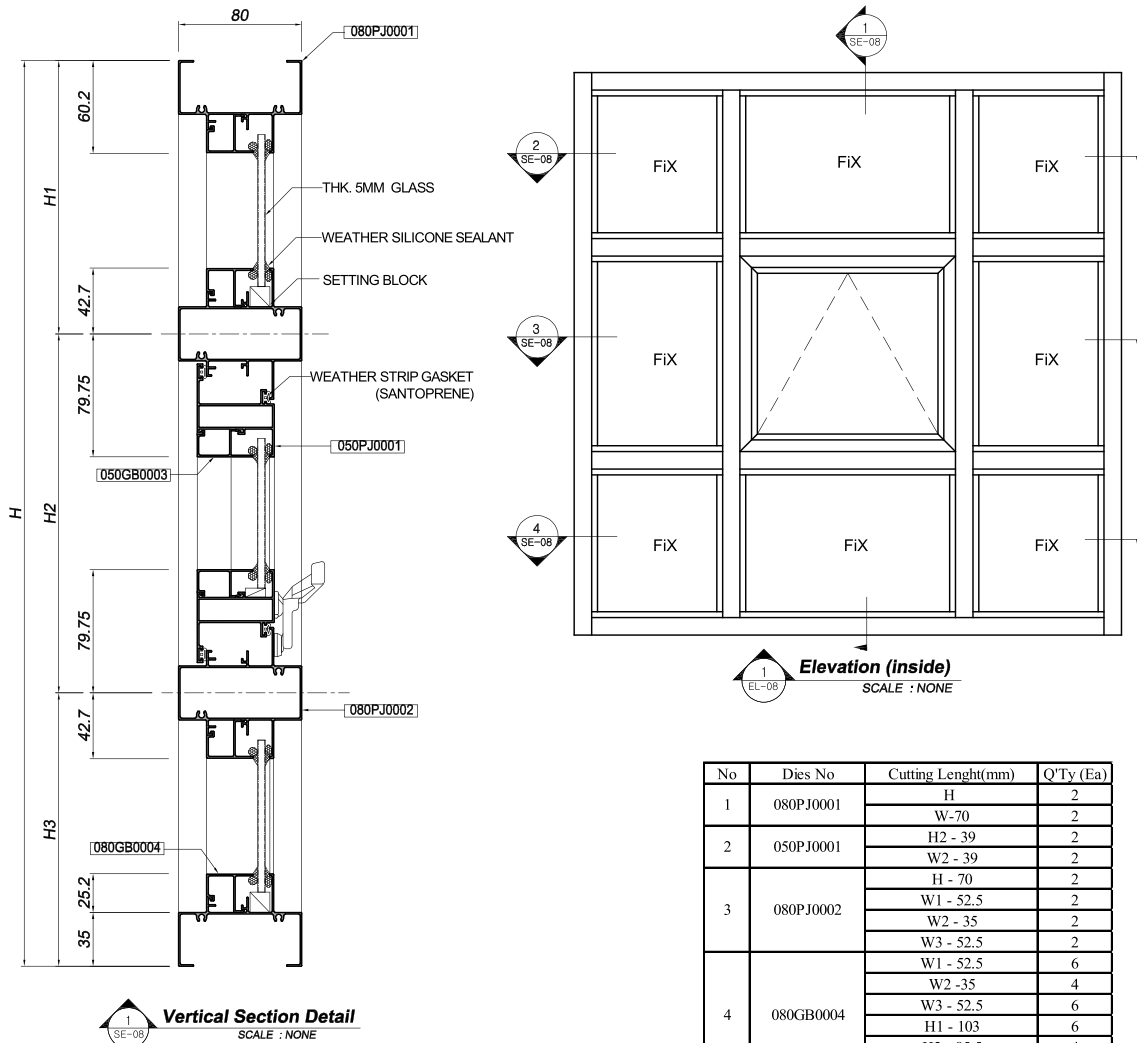

# CỬA LẬT VÀ CỐ ĐỊNH HỆ 100

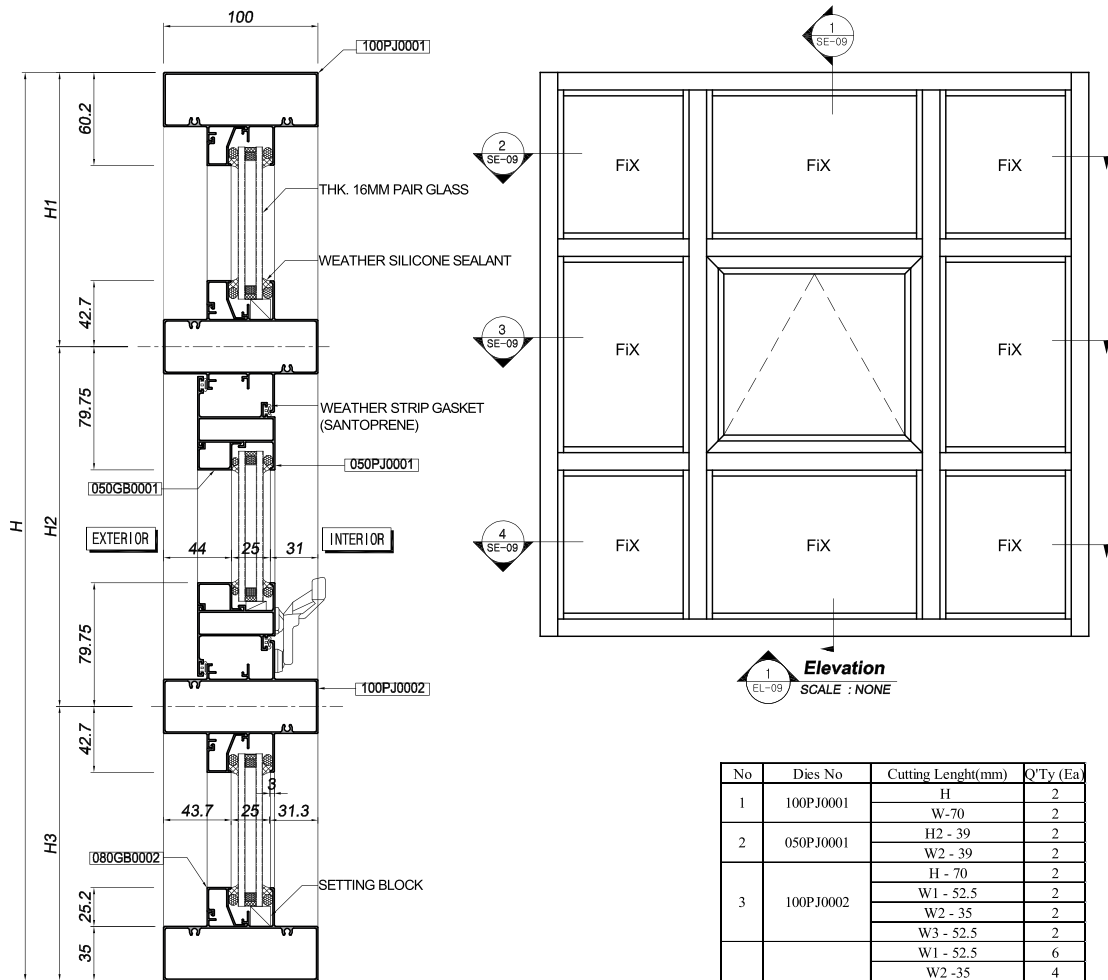

**Elevation**  
SCALE : NONE

**Vertical Section Detail**  
SCALE : NONE

| No | Dies No   | Cutting Length(mm) | Q'Ty (Ea) |
|----|-----------|--------------------|-----------|
| 1  | 100PJ0001 | H                  | 2         |
|    |           | W-70               | 2         |
| 2  | 050PJ0001 | H2 - 39            | 2         |
|    |           | W2 - 39            | 2         |
| 3  | 100PJ0002 | H - 70             | 2         |
|    |           | W1 - 52.5          | 2         |
|    |           | W2 - 35            | 2         |
| 4  | 080GB0004 | W3 - 52.5          | 2         |
|    |           | W1 - 52.5          | 6         |
|    |           | W2 - 35            | 4         |
|    |           | W3 - 52.5          | 6         |
|    |           | H1 - 103           | 6         |
|    |           | H2 - 85.5          | 4         |
| 5  | 050GB0003 | H3 - 103           | 6         |
|    |           | W2 - 124           | 2         |
|    |           | H2 - 160           | 2         |

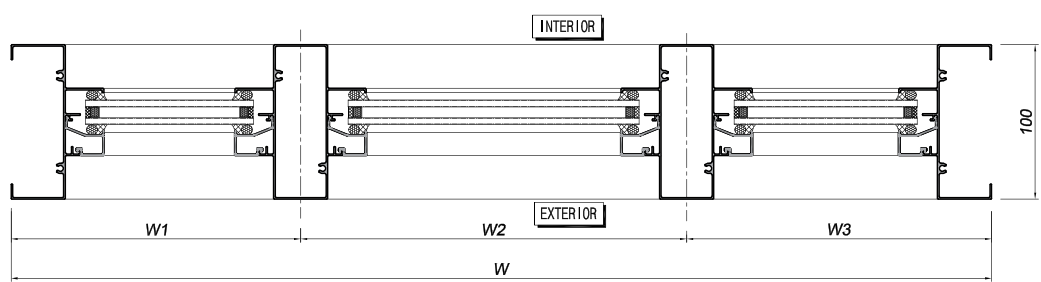

**Horizontal Section Detail**  
SCALE : NONE

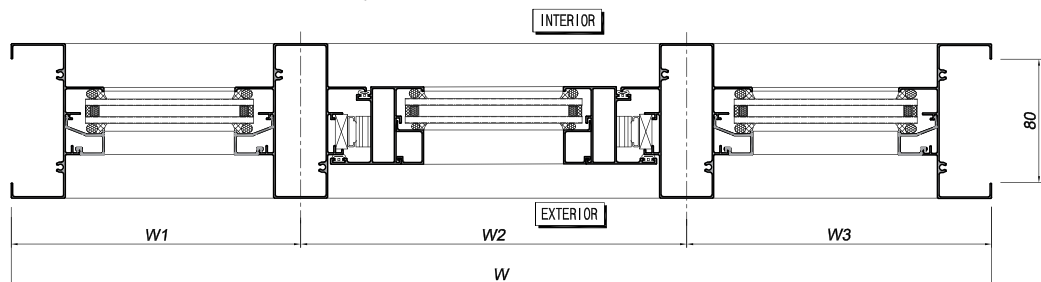

**Horizontal Section Detail**  
SCALE : NONE



# CỬA LẬT VÀ CỐ ĐỊNH HỆ 120

Loại 1

Công nghệ làm nên tương lai phần vịnh

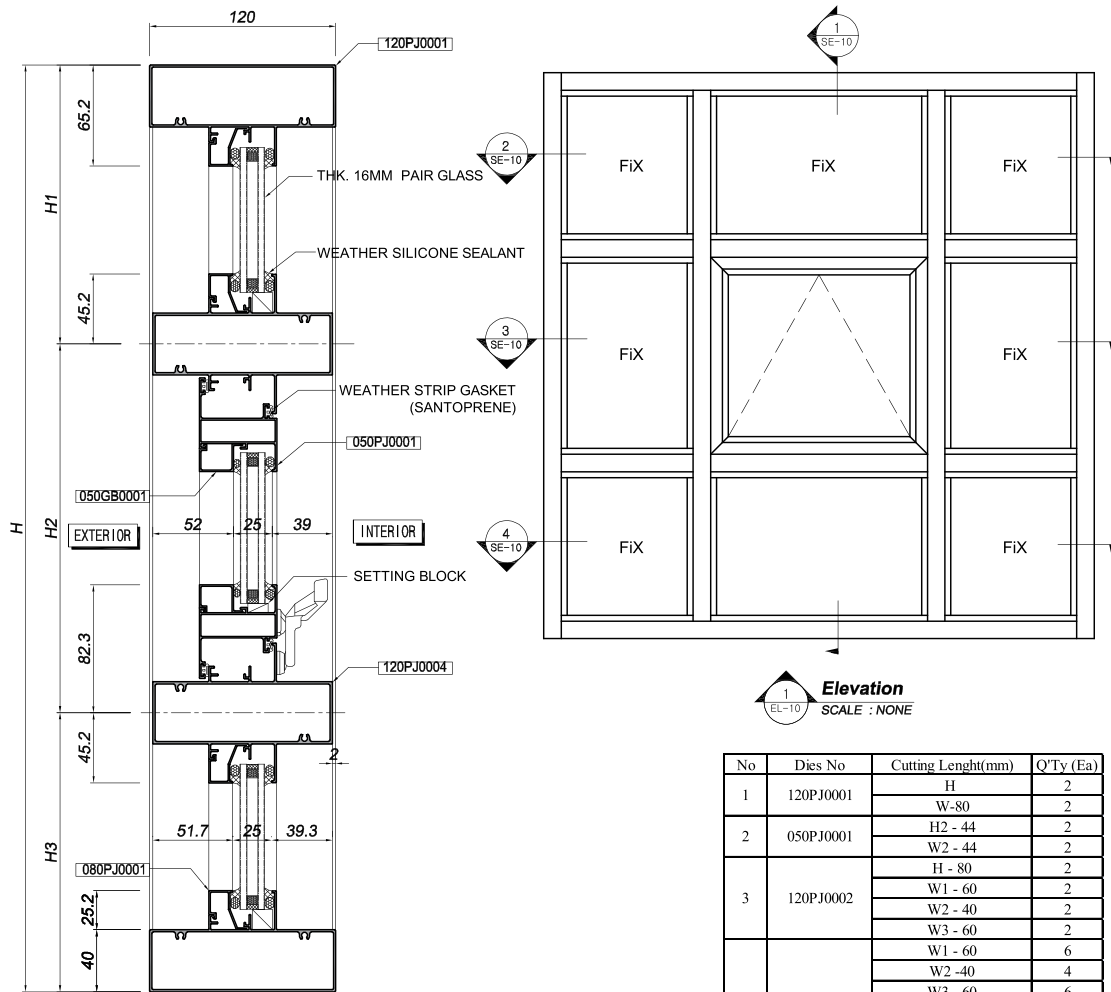

**Vertical Section Detail**  
SCALE : NONE

**Elevation**  
SCALE : NONE

| No | Dies No   | Cutting Length(mm) | Q'Ty (Ea) |
|----|-----------|--------------------|-----------|
| 1  | 120PJ0001 | H                  | 2         |
|    |           | W-80               | 2         |
| 2  | 050PJ0001 | H2 - 44            | 2         |
|    |           | W2 - 44            | 2         |
| 3  | 120PJ0002 | H - 80             | 2         |
|    |           | W1 - 60            | 2         |
|    |           | W2 - 40            | 2         |
| 4  | 080GB0004 | W3 - 60            | 2         |
|    |           | W1 - 60            | 6         |
|    |           | W2 - 40            | 4         |
|    |           | W3 - 60            | 6         |
|    |           | H1 - 110           | 6         |
|    |           | H2 - 90            | 4         |
| 5  | 050GB0003 | H3 - 110           | 6         |
|    |           | W2 - 129           | 2         |
|    |           | H2 - 165           | 2         |

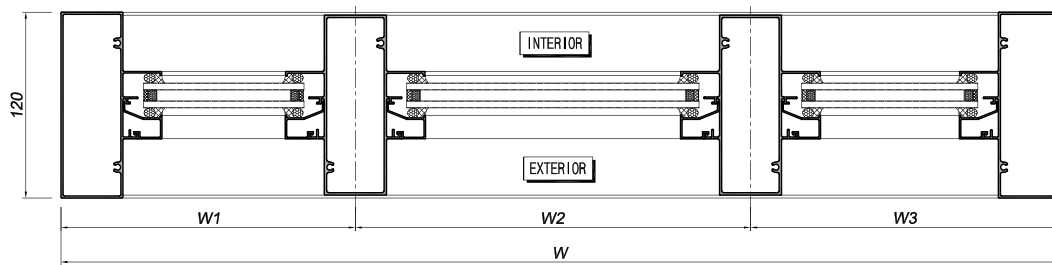

**Horizontal Section Detail**  
SCALE : NONE

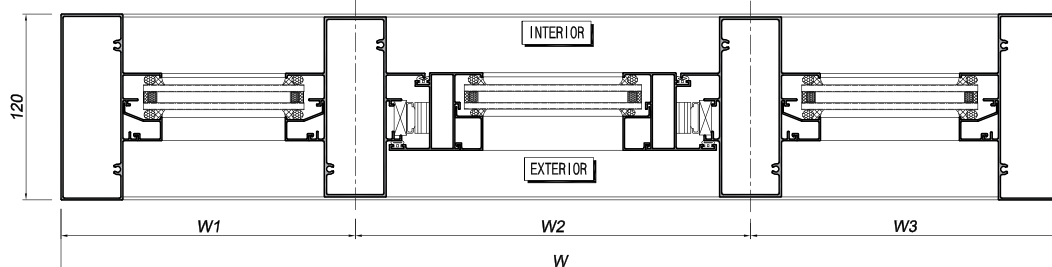

**Horizontal Section Detail**  
SCALE : NONE



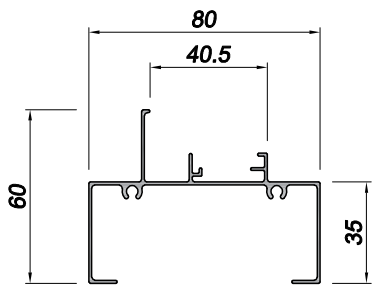

**080PJ0001**  
THK. 1.0 mm - 0.708 Kg/m

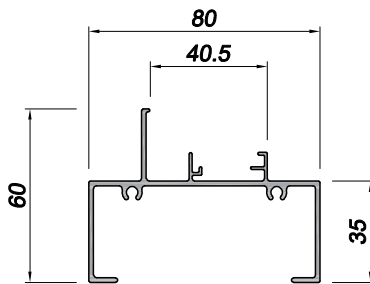

**080PJ001A**  
THK. 1.6 mm - 1.005 Kg/m

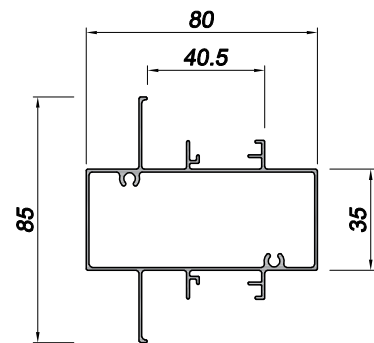

**080PJ0002**  
THK. 1.0 mm - 1.035 Kg/m

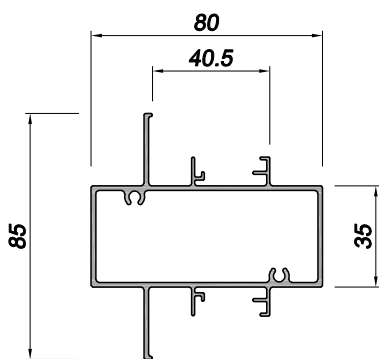

**080PJ002A**  
THK. 1.6 mm - 1.469 Kg/m

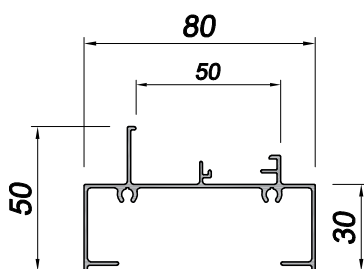

**NAH-0001**  
THK. 1.2 mm - 0.777 Kg/m

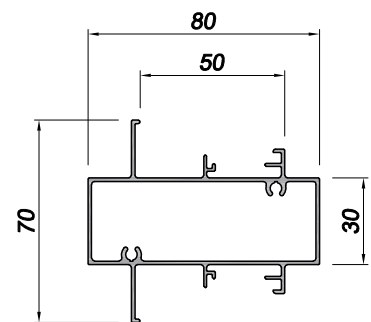

**NAH-0002**  
THK. 1.2 mm - 1.123 Kg/m

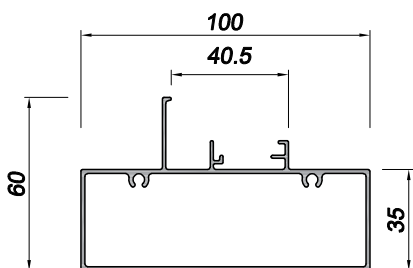

**100PJ0001**  
THK. 1.35 mm - 1.236 Kg/m

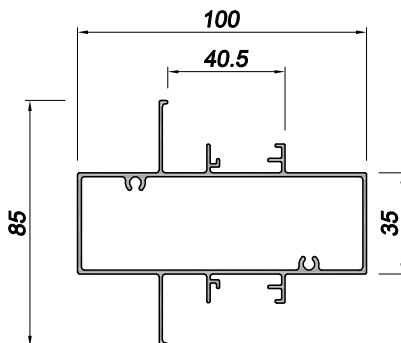

**100PJ0002**  
THK. 1.35 mm - 1.414 Kg/m

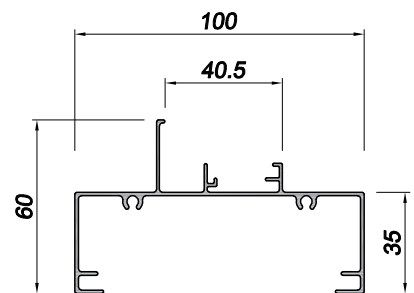

**100PJ0003**  
THK. 1.2 mm - 0.899Kg/m

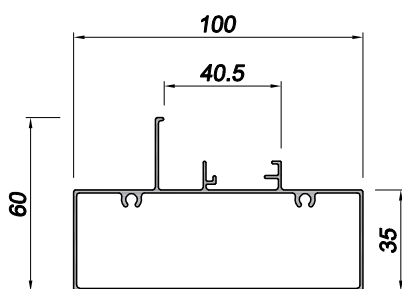

**100PJ0004**  
THK. 1.0 mm - 1.000 Kg/m

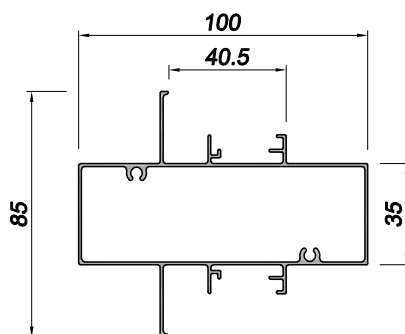

**100PJ0005**  
THK. 1.0 mm - 1.179 Kg/m

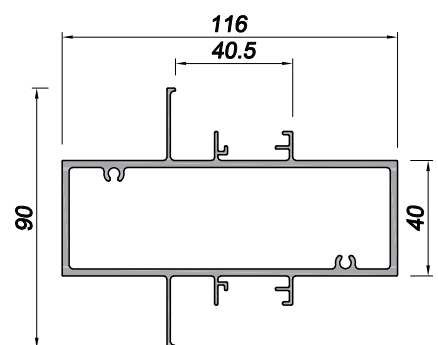

**120PJ0003**  
THK. 2.5 mm - 2.510 Kg/m

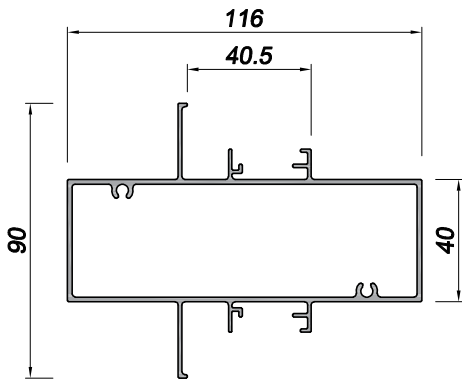

**120PJ0004**  
THK. 1.5 mm - 1.708 Kg/m

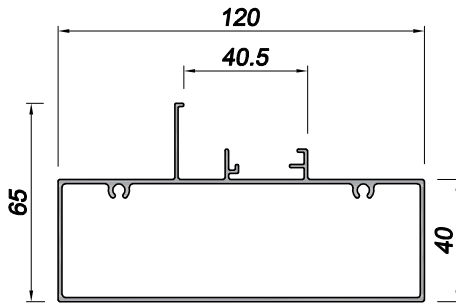

**120PJ0001**  
THK. 1.35 mm - 1.419 Kg/m

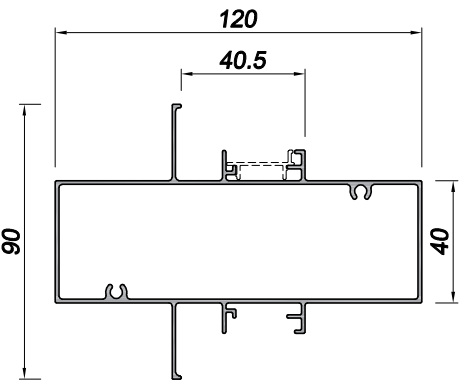

**120PJ0002**  
THK. 1.2 mm - 1.478 Kg/m

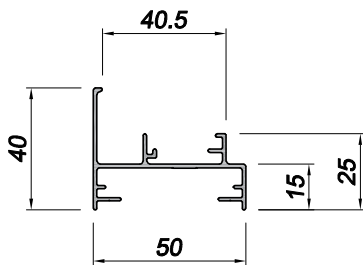

**050PJ0003**  
THK. 1.2 mm - 0.507 Kg/m

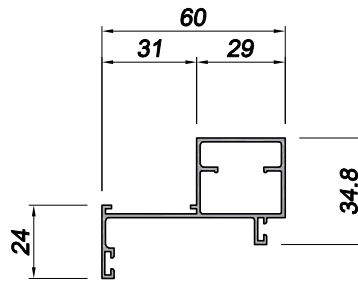

**NAH-0007**  
THK. 1.2 mm - 0.643 Kg/m

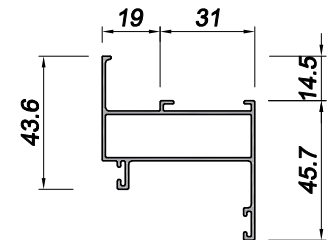

**050PJ0001**  
THK. 1.1 mm - 0.635 Kg/m

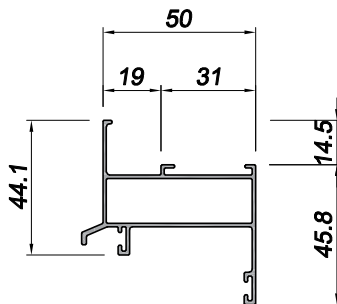

**050PJ0002**  
THK. 1.1 mm - 0.685 Kg/m

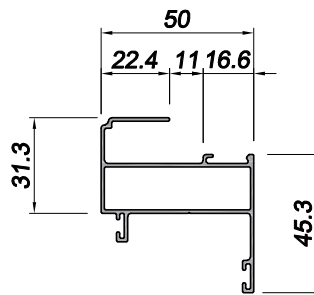

**MUL002540**  
THK. 1.1 mm - 0.677 Kg/m

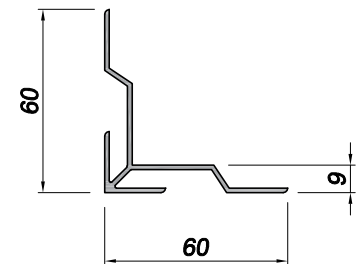

**060CP0009**  
THK. 1.5 mm - 0.641 Kg/m

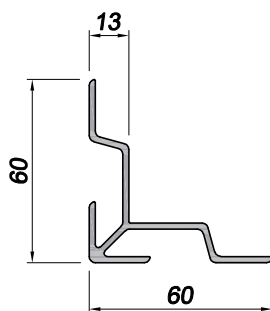

**060CP0013**  
THK. 2.0mm - 0.882 Kg/m

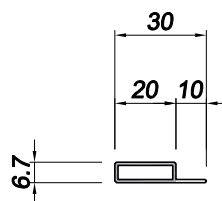

**ARM000002**  
THK. 1.0 mm - 0.160 Kg/m

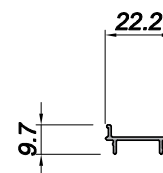

**ARM000001**  
THK. 1.0 mm - 0.098 Kg/m

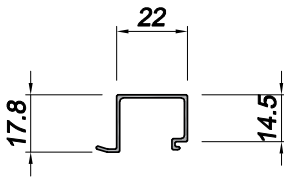

(G: 25mm)

**050GB0001**

THK. 0.95 mm - 0.173 Kg/m

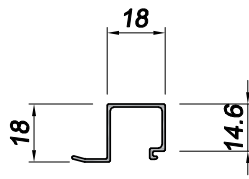

(G: 29mm)

**050GB0002**

THK. 0.95 mm - 0.175 Kg/m

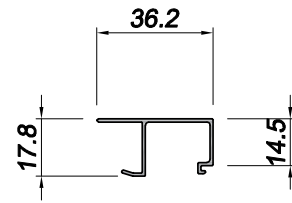

(G: 11mm)

**050GB0003**

THK. 0.95 mm - 0.210Kg/m

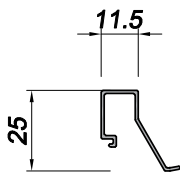

(G: 29mm)

**080GB0001**

THK. 0.95 mm - 0.164 Kg/m

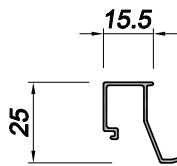

(G: 25mm)

**080GB0002**

THK. 0.95 mm - 0.176 Kg/m

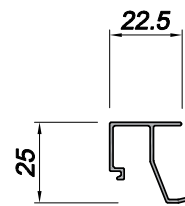

(G: 18mm)

**080GB0003**

THK. 1.0 mm - 0.203 Kg/m

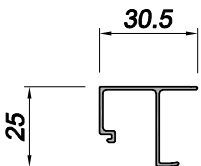

(G: 10mm)

**080GB0004**

THK. 1.0 mm - 0.224 Kg/m

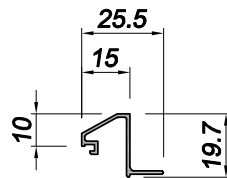

**NAH-0005**

THK. 1 mm - 0.156 Kg/m

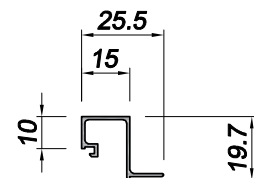

**NAH-0006**

THK. 1 mm - 0.169 Kg/m

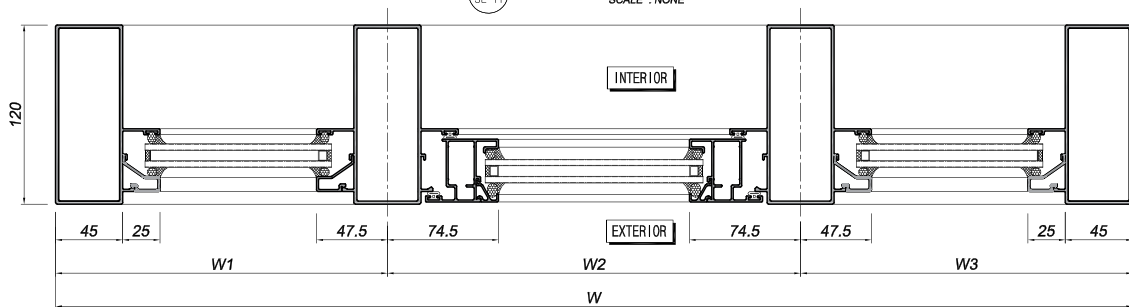
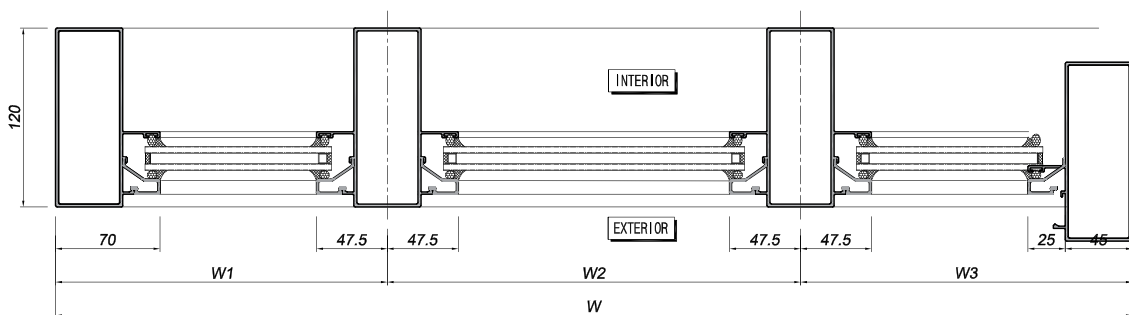
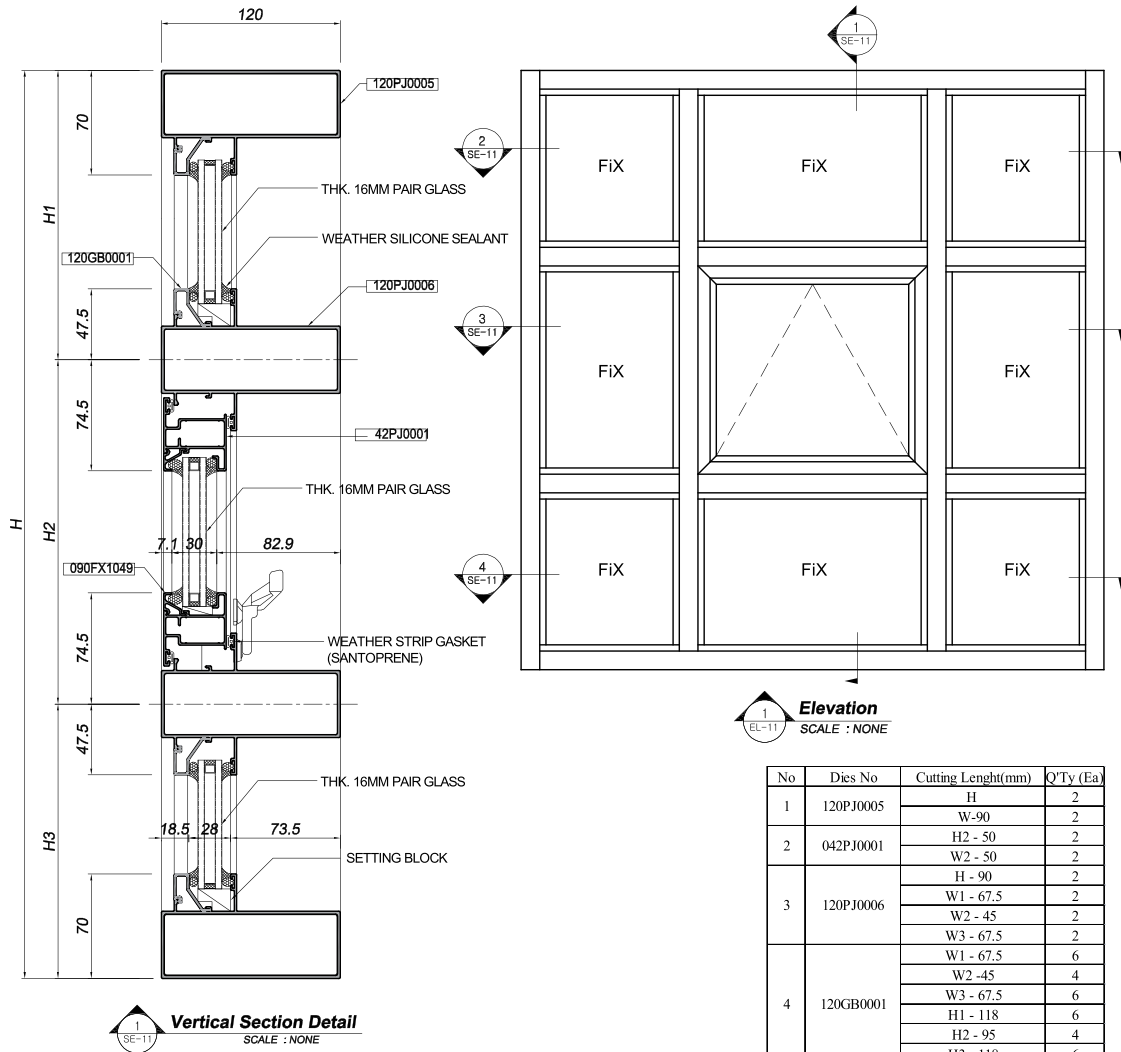



# CỬA LẬT VÀ CỐ ĐỊNH HỆ 120

Loại 2

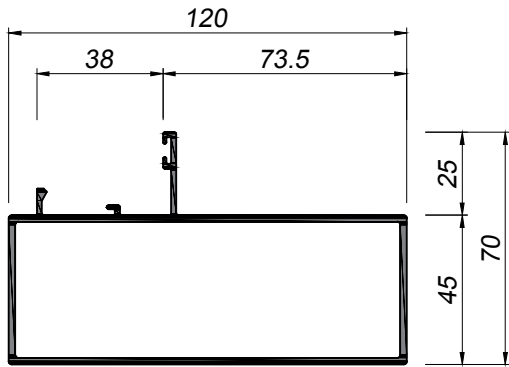

**120PJ0005**  
THK. 2.0 mm - 1.938 Kg/m

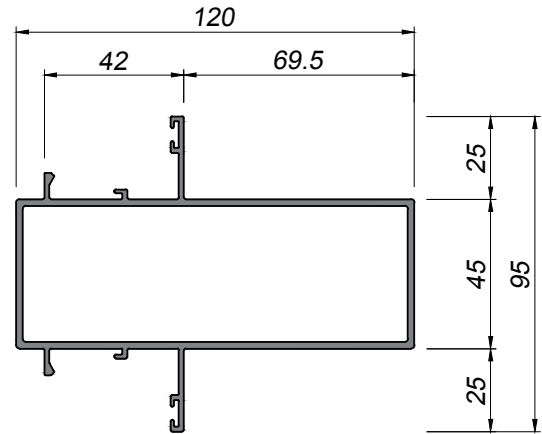

**120PJ0006**  
THK. 2.0 mm - 2.132 Kg/m

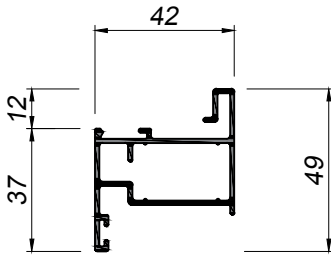

**042PJ0001**  
THK. 1.3mm - 0.706Kg/m

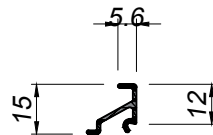

(G: 29mm)  
**090FX1049**  
THK. 1.1 mm - 0.124 Kg/m

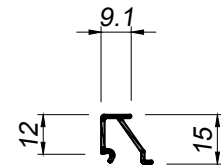

(G: 26.5mm)  
**042GB0001**  
THK. 1.1 mm - 0.132 Kg/m

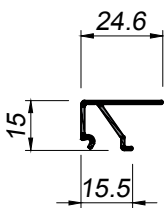

(G: 10mm)  
**042GB0002**  
THK. 1.1 mm - 0.178 Kg/m

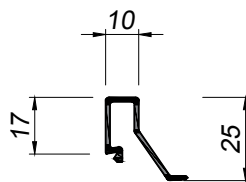

(G: 28mm)  
**120GB0001**  
THK. 1.3 mm - 0.229 Kg/m

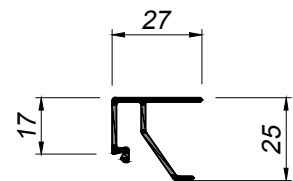

(G: 10mm)  
**120GB0002**  
THK. 1.3 mm - 0.289 Kg/m



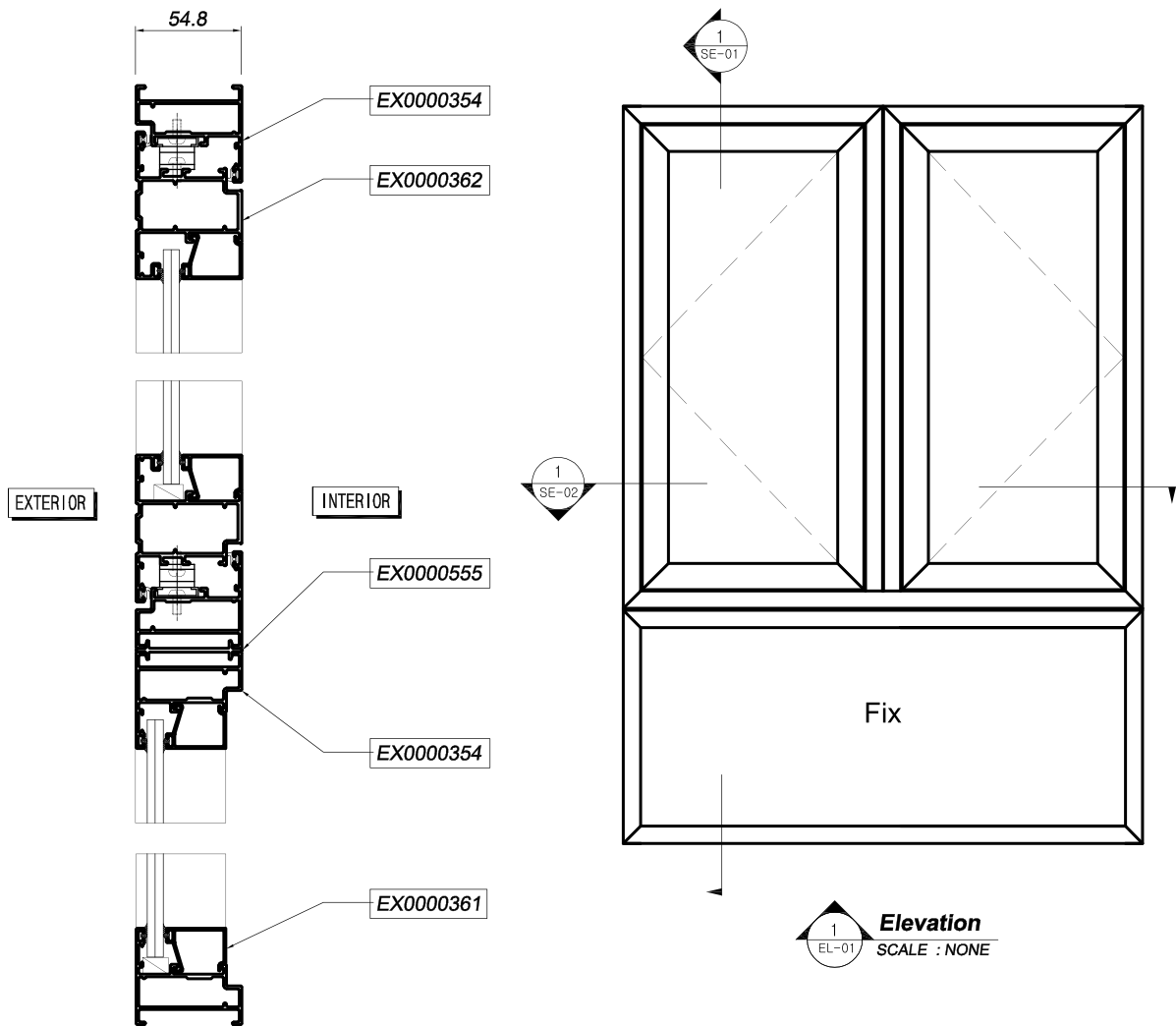

**Vertical Section Detail**  
SCALE : NONE

**Elevation**  
SCALE : NONE

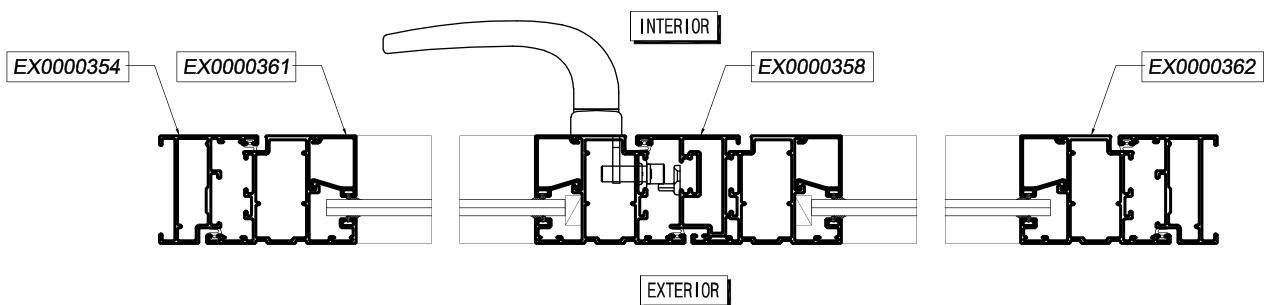

**Horizontal Section Detail**  
SCALE : NONE

**Phụ kiện:**



# CỬA MỞ LẬT VÀ CỐ ĐỊNH HỆ HD55

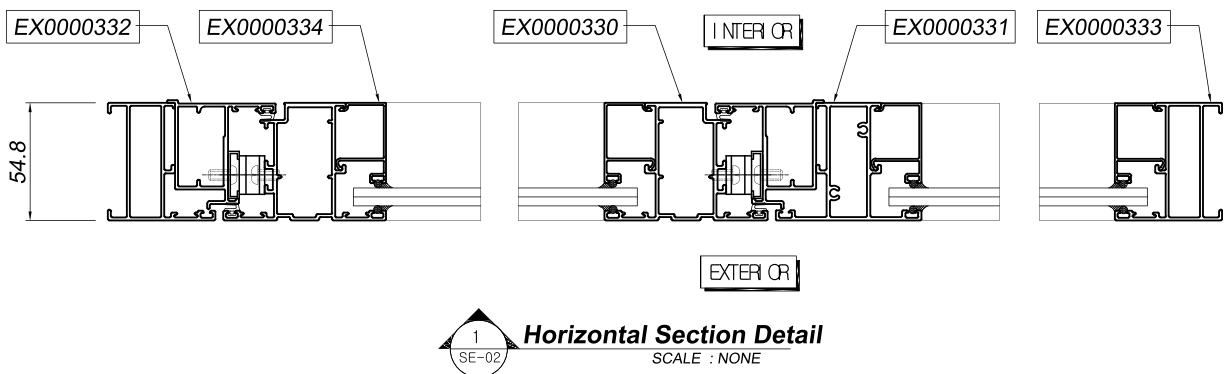
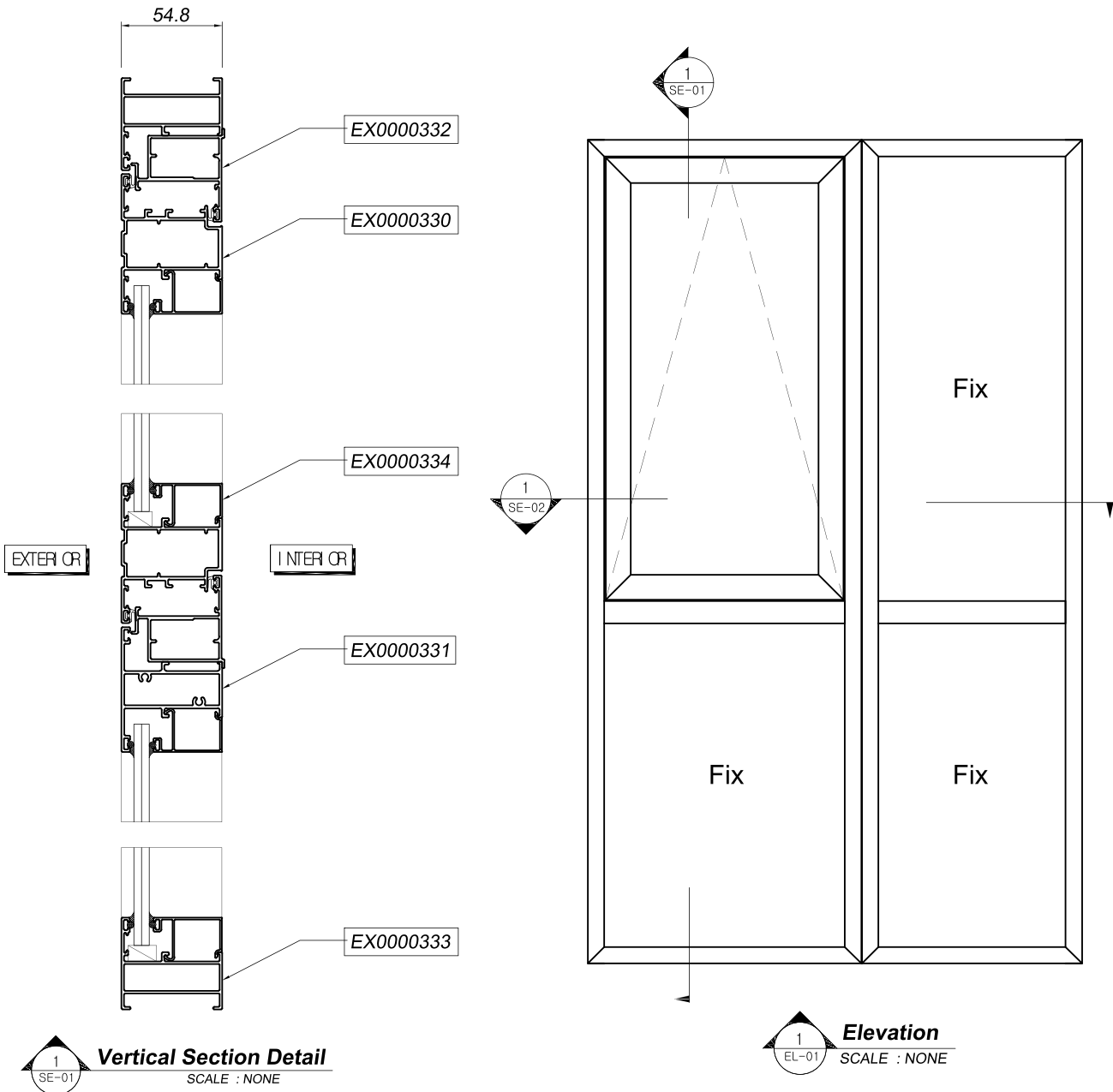

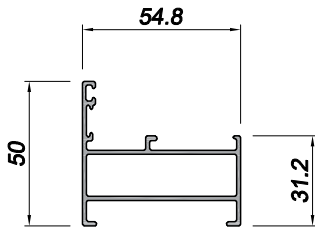

**EX0000333 (C3209)**  
THK. 1.4 mm - 0.805 Kg/m

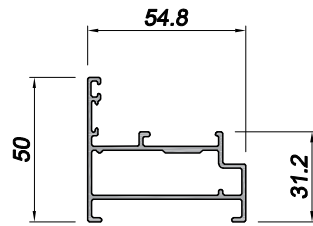

**EX0000354 (C3318)**  
THK. 1.4 mm - 0.848 Kg/m

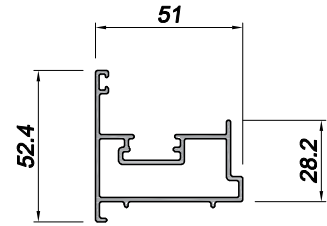

**EX0000358 (C3033)**  
THK. 1.4 mm - 0.828 Kg/m

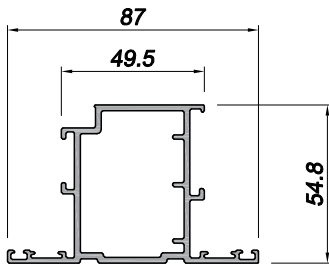

**EX0000692 (C3303)**  
THK. 2.0 mm - 1.447 Kg/m

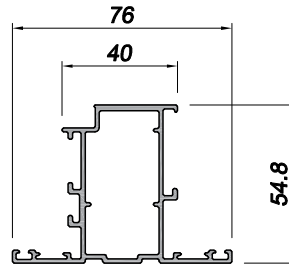

**EX0000330 (C3202)**  
THK. 1.4 mm - 1.092 Kg/m

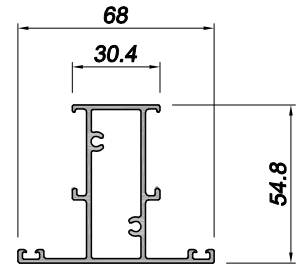

**EX00000331 (C3203)**  
THK. 1.6 mm - 1.072 Kg/m

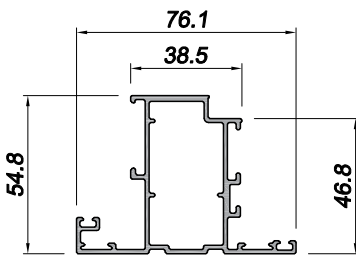

**EX0000362 (C2912)**  
THK. 1.4 mm - 1.145 Kg/m

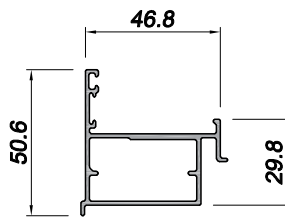

**EX0000332 (C3208)**  
THK. 1.4 mm - 0.762 Kg/m

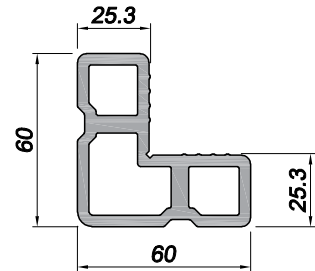

**EX0000342 (C1697)**  
THK. 4.0 mm - 2.898 Kg/m

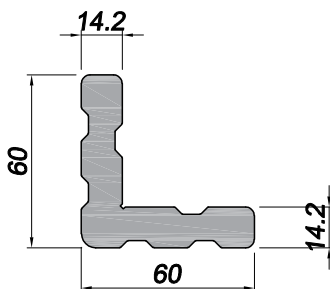

**EX0000341 (C1687)**  
THK. 14.2 mm - 3.668 Kg/m

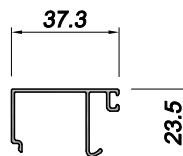

**EX0000334 (C3295)**  
THK. 1.0 mm - 0.272 Kg/m

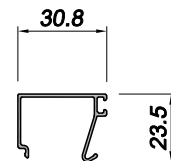

**EX0000361 (C3296)**  
THK. 1.0 mm - 0.238 Kg/m

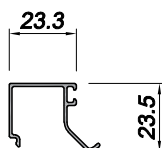

**EX0000693 (C3286)**  
THK. 1.0 mm - 0.224 Kg/m

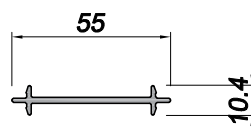

**EX0000555 (C3300)**  
THK. 2.0 mm - 0.348 Kg/m

## Mặt dựng:

*“ Hoàn hảo từ thiết kế đến Thi công”*

## Đặc tính:

Một ứng dụng hoàn toàn mới trong xây dựng, đẩy nhanh tiến độ hoàn thiện công trình mà vẫn đảm bảo được sự vững chắc, chống chọi với mọi điều kiện thời tiết.

Kết cấu thanh Profile Nhôm cường độ cao thoả mãn mọi thiết kế kiến trúc. Từ những Biệt thự sang trọng đến những toà nhà chọc trời.

Màu sắc đa dạng (Sơn tĩnh điện, PVDF, vân gỗ, Anodized...), có thể đáp ứng những yêu cầu khắt khe nhất của từng hạng mục công trình.



## Công trình đã thi công:



KEANGNAM LANDMARK TOWER  
(Hà Nội- Việt Nam)



THE LANDMARK 81  
(Hồ Chí Minh- Việt Nam)



JONGRO TOWER  
(Hàn Quốc)



DISCOVERY COMPLEX  
(Hà Nội - Việt Nam)

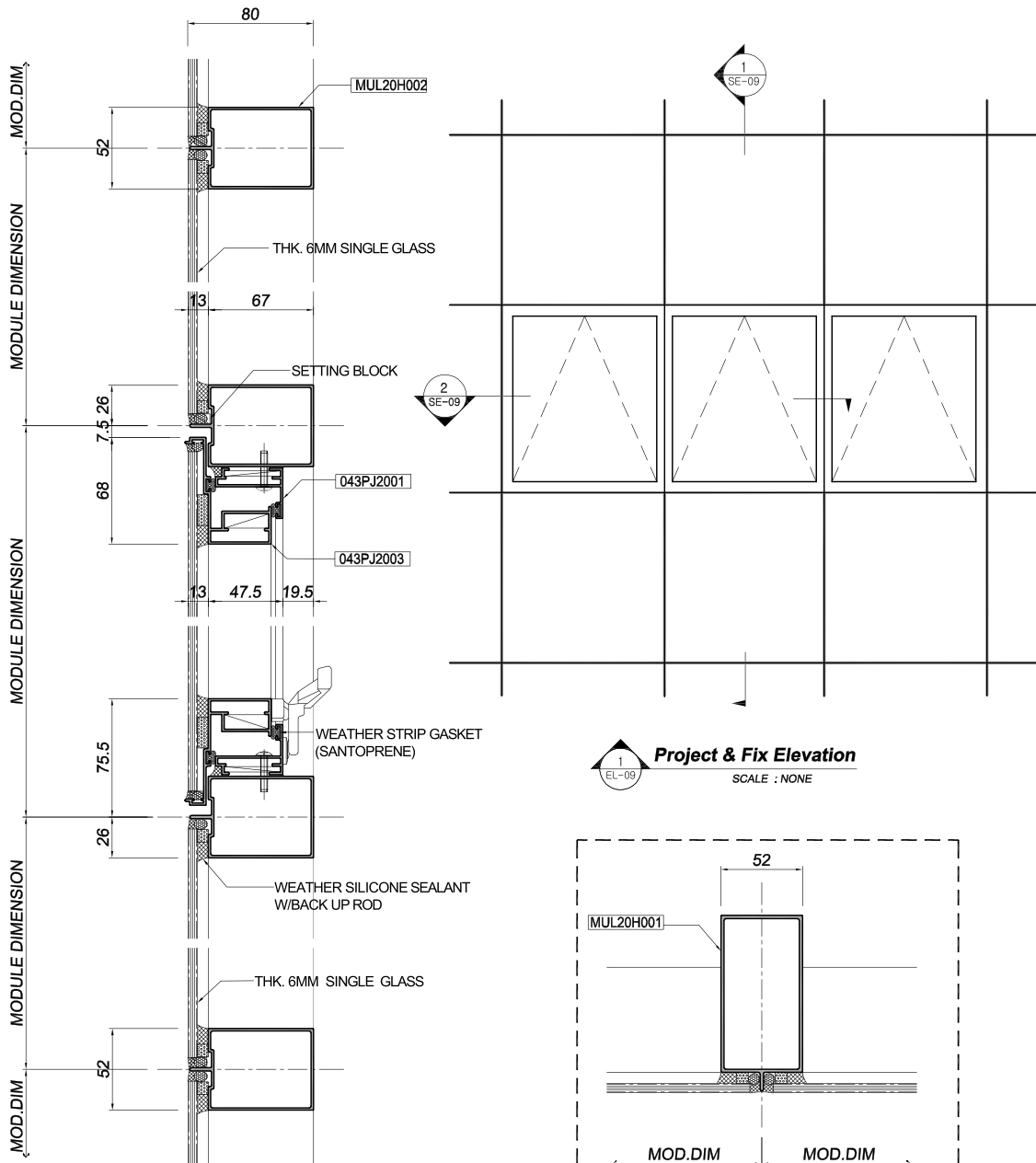

**1 Project & Fix Elevation**  
SCALE : NONE

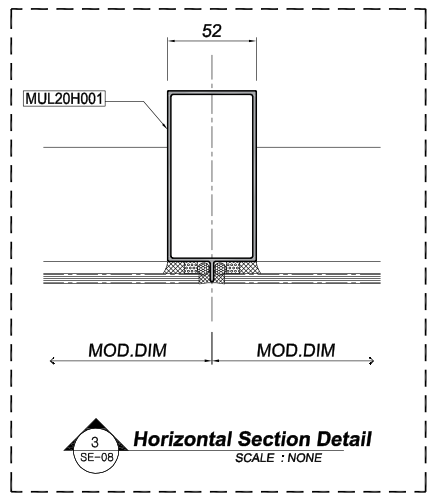

**3 Horizontal Section Detail**  
SCALE : NONE

**1 Vertical Section Detail**  
SCALE : NONE

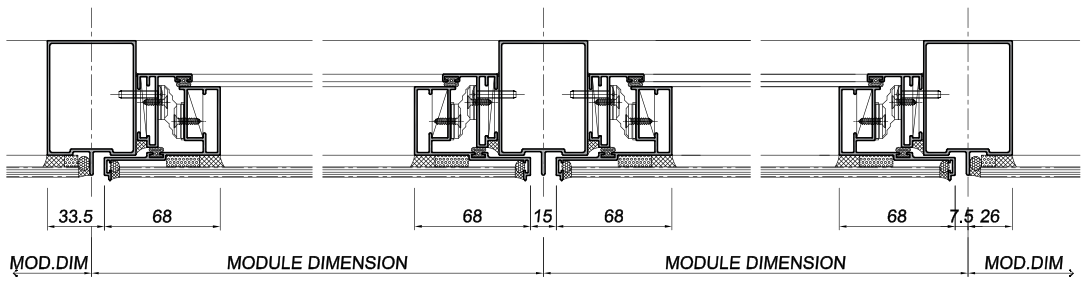

**3 Horizontal Section Detail**  
SCALE : NONE



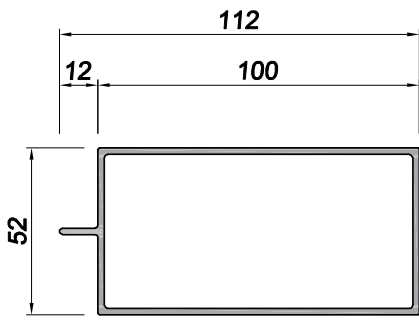

**MUL20H001**  
THK. 2.0mm - 1.671 Kg/m

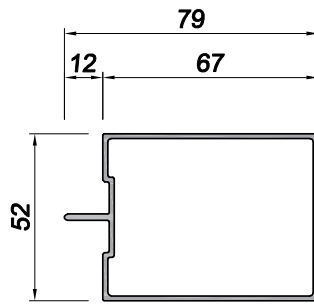

**MUL20H002**  
THK. 1.5mm - 1.036 Kg/m

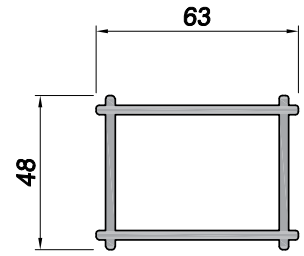

**MUL20H004**  
THK. 3.0mm - 1.698 Kg/m

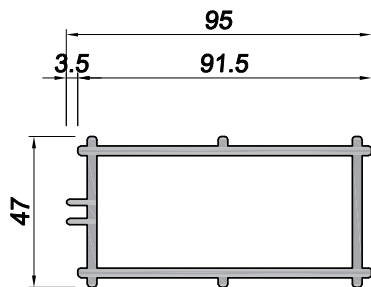

**MUL20C011**  
THK. 3.0mm - 2.260 Kg/m

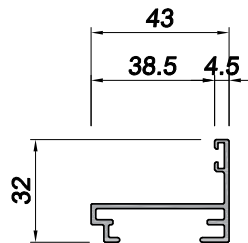

**043PJ2001**  
THK. 1.5mm - 0.455 Kg/m

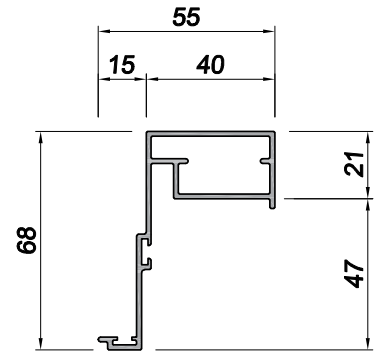

**043PJ2003**  
THK. 1.5mm - 0.845 Kg/m

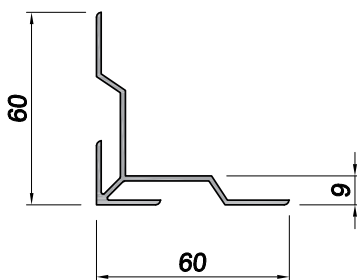

**060CP0009**  
THK. 1.5 mm - 0.641 Kg/m



# MẶT DỰNG HỆ 100

Loại 1

Công nghệ làm nên tương lai phần vịnh

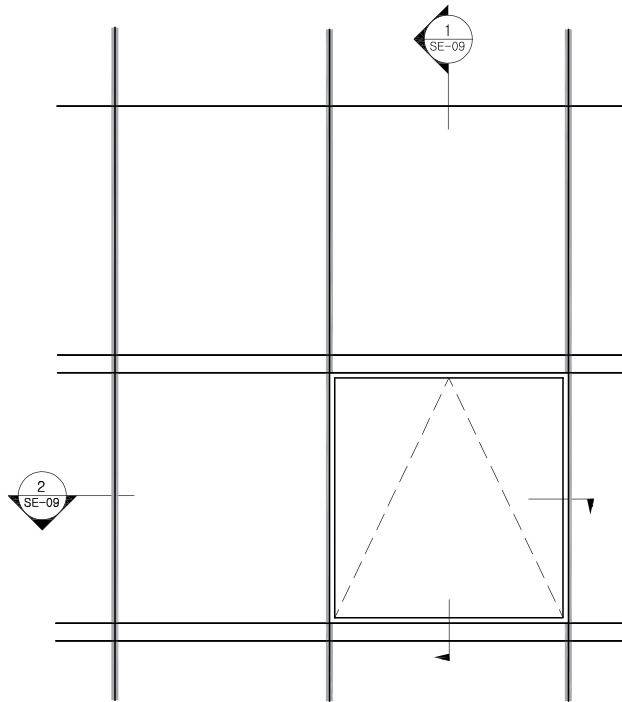
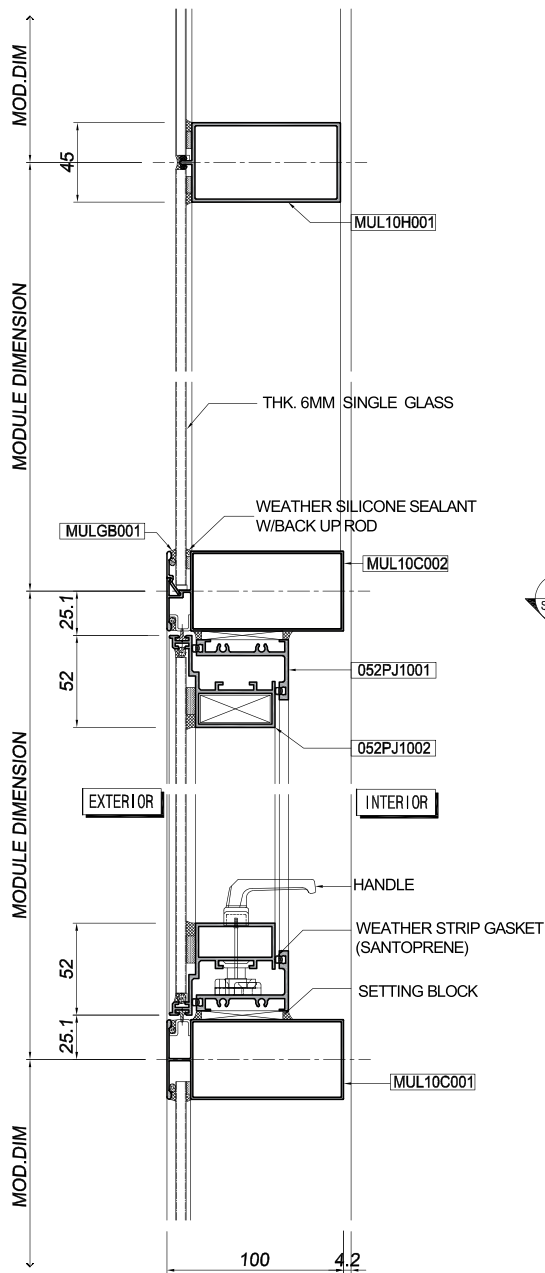

**Project & Fix Elevation**  
SCALE : NONE

**Vertical Section Detail**  
SCALE : NONE

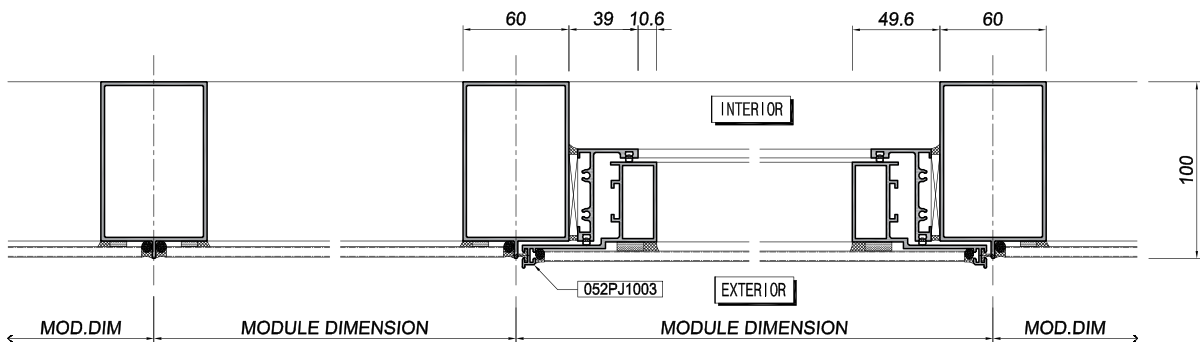

**Horizontal Section Detail**  
SCALE : NONE



# MẶT DỤNG HỆ 100

Loại 1

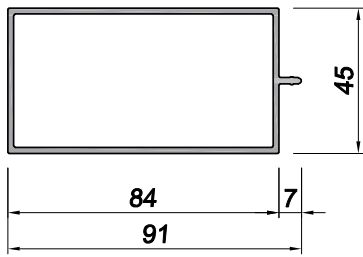

**MUL10H001**  
THK. 1.8mm - 1.262 Kg/m

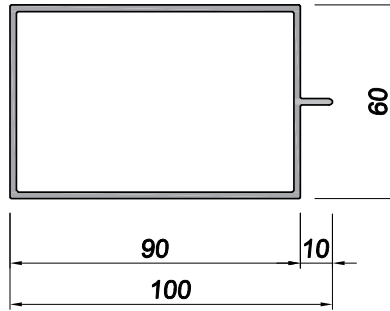

**MUL10H002**  
THK. 2.0mm - 1.636 Kg/m

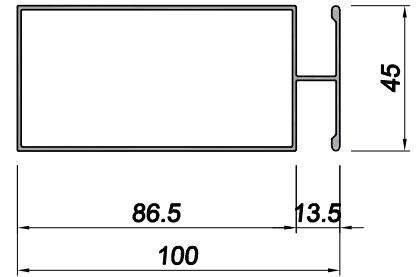

**MUL10C001**  
THK. 1.2mm - 1.053 Kg/m

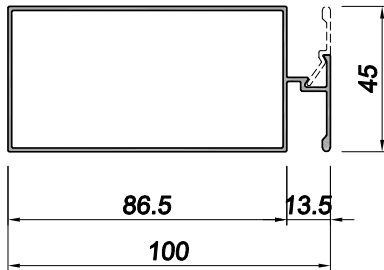

**MUL10C002**  
THK. 1.2mm - 1.008 Kg/m

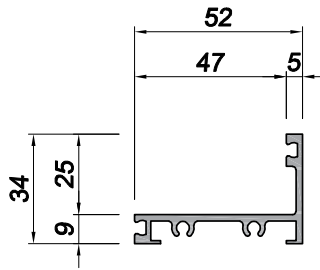

**052PJ1001**  
THK. 2.0mm - 0.656 Kg/m

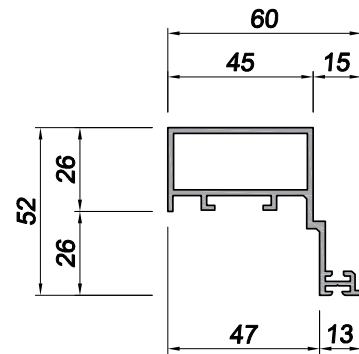

**052PJ1002**  
THK. 1.8mm - 0.969 Kg/m

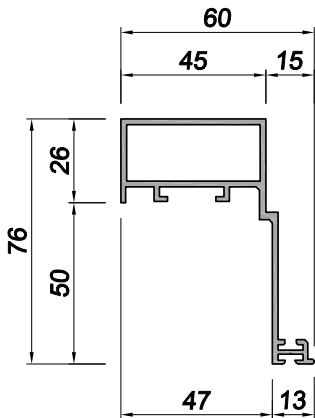

**052PJ1003**  
THK. 1.8mm - 1.086Kg/m

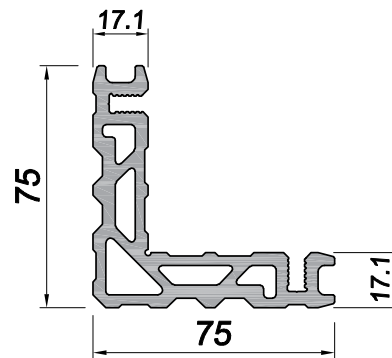

**075CP0017**  
THK. 3.0mm - 3.400 Kg/m

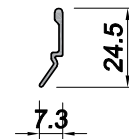

**MULGB001**  
THK. 1.2mm - 0.106 Kg/m



# MẶT DỰNG HỆ 100

Loại 2

Công nghệ làm nên tương lai phồn vinh

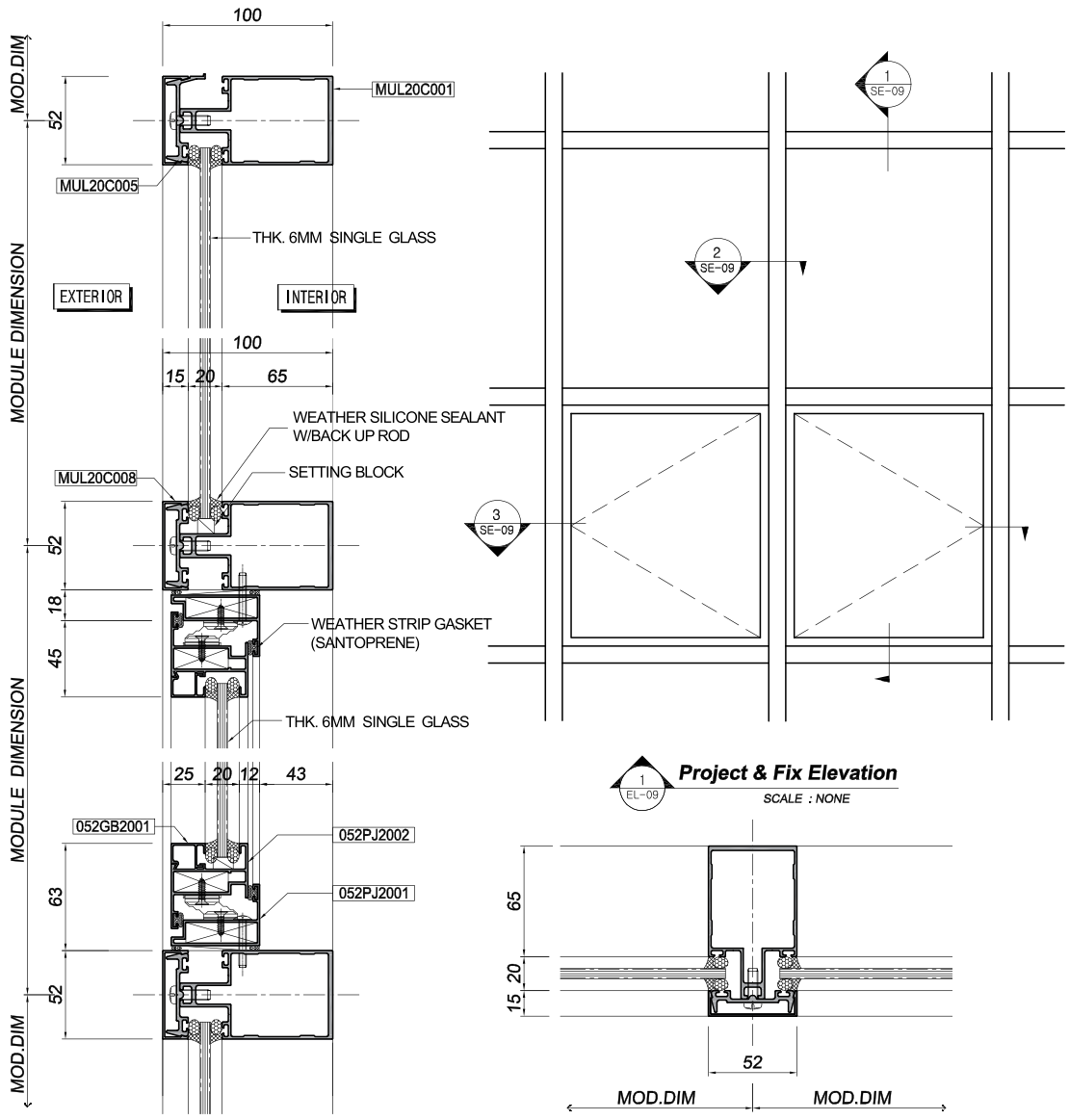

**1** Vertical Section Detail  
SCALE : NONE

**2** Horizontal Section Detail  
SCALE : NONE

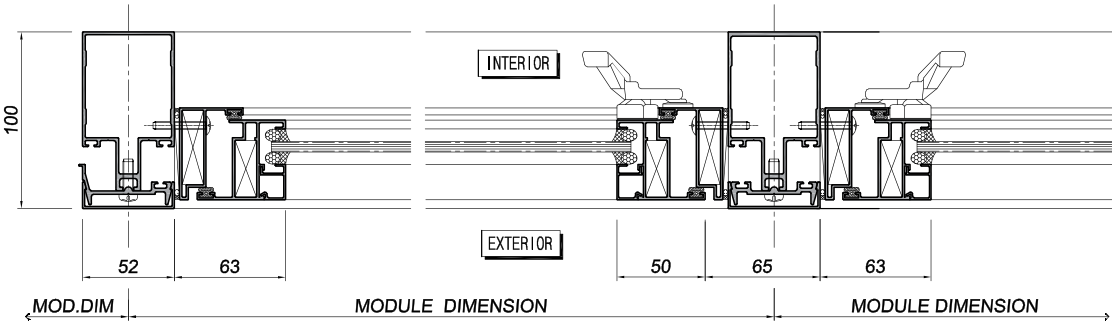

**3** Horizontal Section Detail  
SCALE : NONE



# MẶT DỤNG HỆ 100

Loại 2

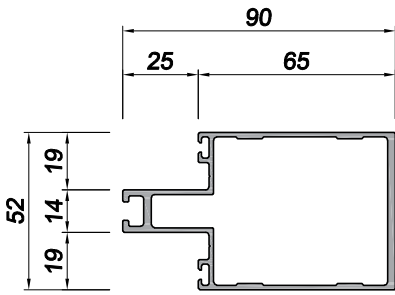

**MUL20C001**  
THK. 1.5mm - 1.473 Kg/m

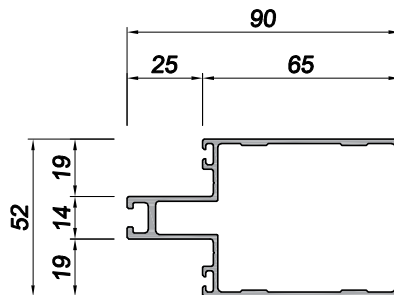

**MUL20C002**  
THK. 1.5mm - 1.340 Kg/m

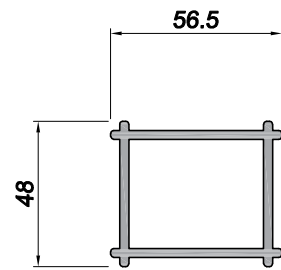

**MUL20C010**  
THK. 3.0mm - 1.592 Kg/m

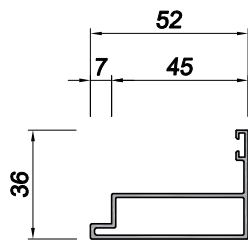

**052PJ2001**  
THK. 1.3mm - 0.547 Kg/m

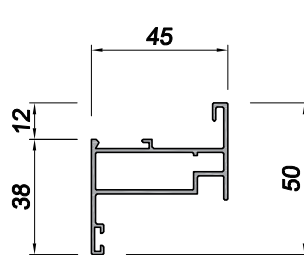

**052PJ2002**  
THK. 1.3mm - 0.635 Kg/m

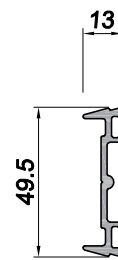

**MUL20C004**  
THK. 2.0mm - 0.490 Kg/m

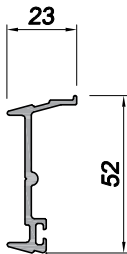

**MUL20C005**  
THK. 2.0mm - 0.494 Kg/m

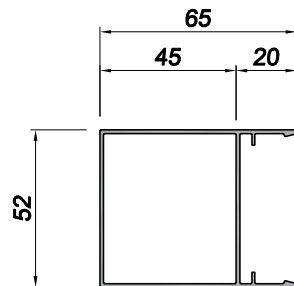

**MUL20C006**  
THK. 1.2mm - 0.779 Kg/m

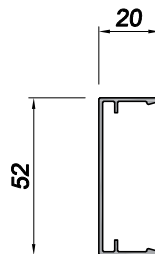

**MUL20C007**  
THK. 1.2mm - 0.325 Kg/m

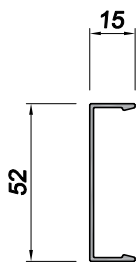

**MUL20C008**  
THK. 1.2mm - 0.271 Kg/m

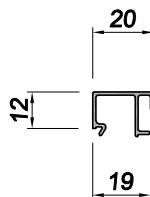

(G:20mm)  
**052GB2001**  
THK. 1.0mm - 0.164 Kg/m

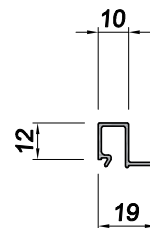

(G:30mm)  
**052GB3001**  
THK. 1.0mm - 0.137 Kg/m





# MẶT DỰNG HỆ 100

Loại 3

Công nghệ làm nên tương lai phần vịnh

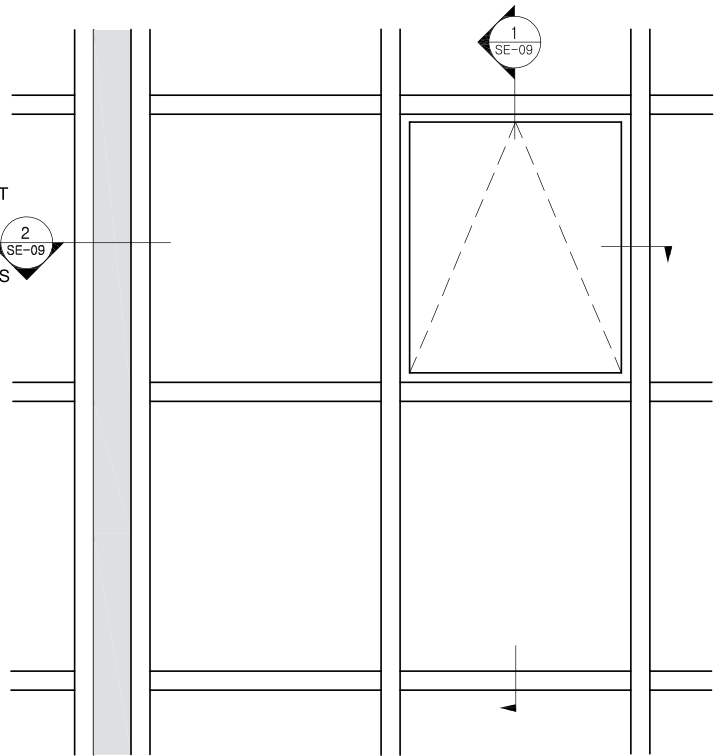
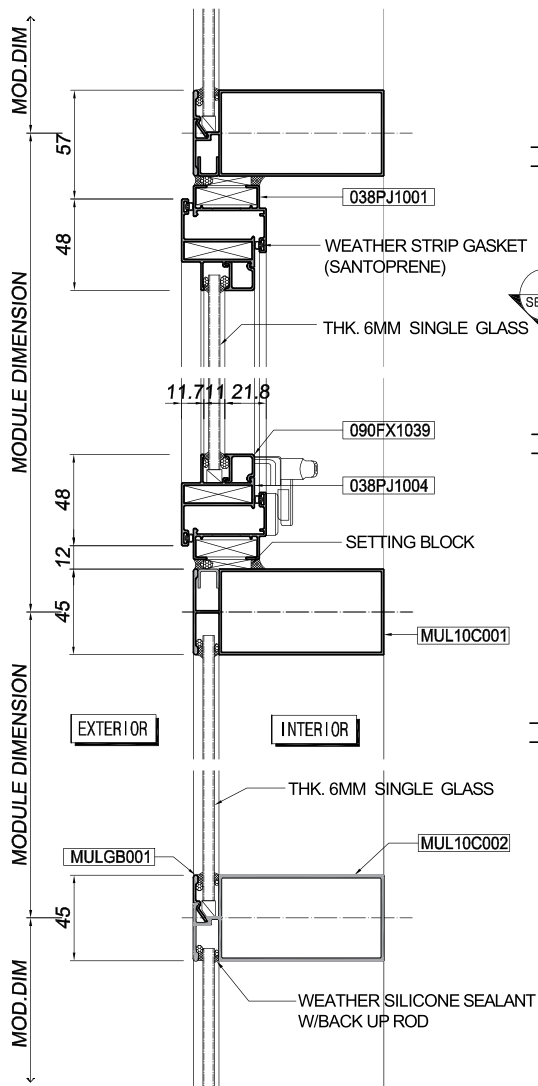

**Project & Fix Elevation**  
SCALE : NONE

**Vertical Section Detail**  
SCALE : NONE

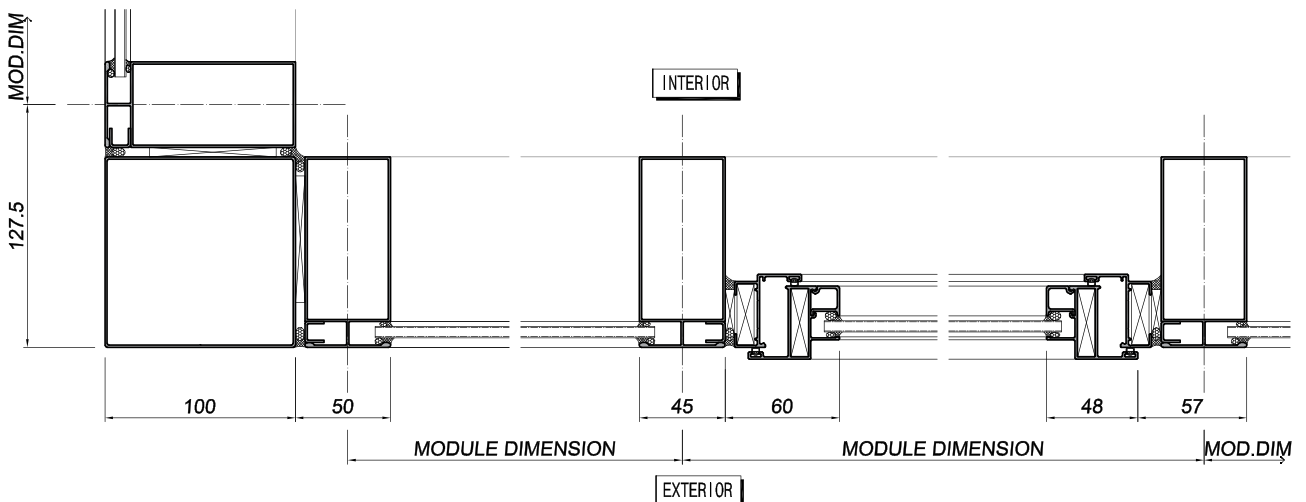

**Horizontal Section Detail**  
SCALE : NONE



# MẶT DỰNG HỆ 100

Loại 3

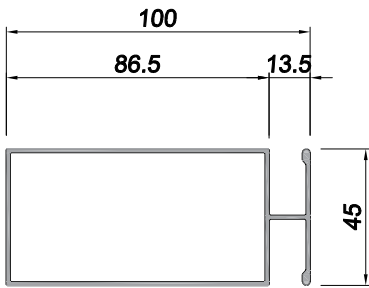

**MUL10C001**  
THK. 1.2mm - 1.053 Kg/m

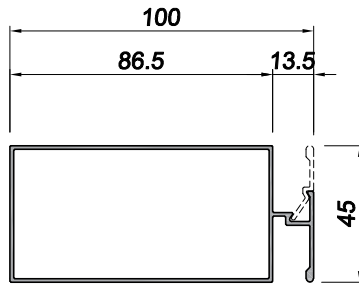

**MUL10C002**  
THK. 1.2mm - 1.008 Kg/m

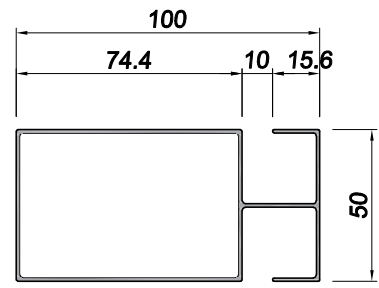

**MUL10C003**  
THK. 1.1mm - 1.041 Kg/m

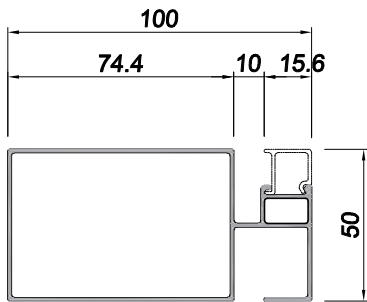

**MUL10C004**  
THK. 1.1mm - 1.058Kg/m

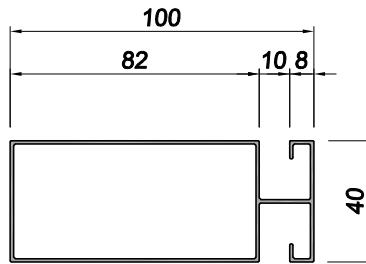

**MUL10C005**  
THK. 1.1mm - 0.955 Kg/m

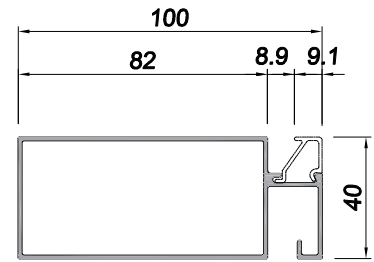

**MUL10C006**  
THK. 1.1mm - 0.914 Kg/m

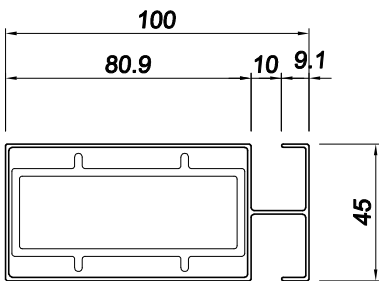

**MUL10C007**  
THK. 1.1mm - 0.976 Kg/m

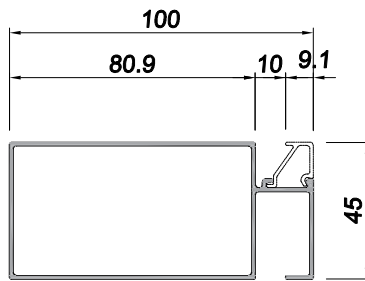

**MUL10C008**  
THK. 1.1mm - 0.940 Kg/m

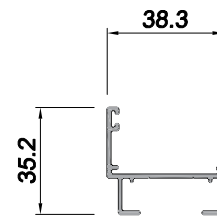

**038PJ1001**  
THK. 1.2mm - 0.337 Kg/m

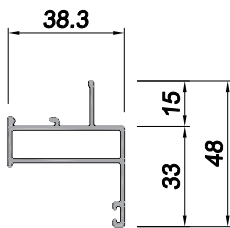

**038PJ1004**  
THK. 1.2mm - 0.477 Kg/m

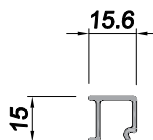

(G : 10mm)  
**090FX1039**  
THK. 1.1mm - 0.145 Kg/m

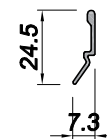

**MULGB001**  
THK. 1.2mm - 0.106 Kg/m



# MẶT DỰNG HỆ 100

Loại 3

Công nghệ làm nên tương lai phần vịnh

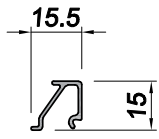

(G : 9mm)

**042GB0001**

THK. 1.1mm - 0.132 Kg/m

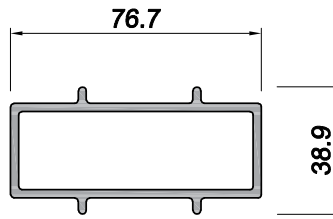

**MUL10C009**

THK. 2.5mm - 1.496Kg/m

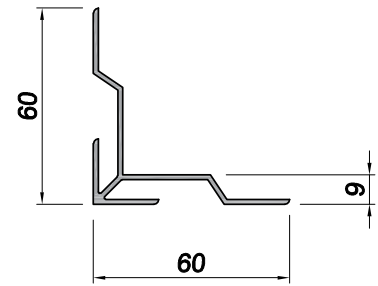

**060CP0009**

THK. 1.5mm - 0.641 Kg/m

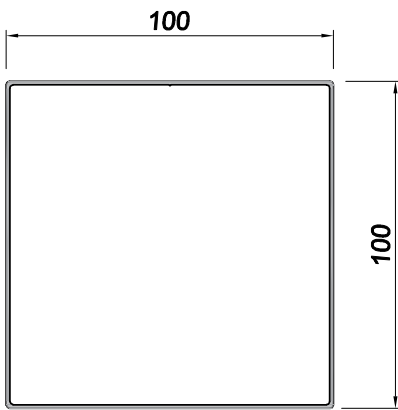

**100PS0100**

THK. 1.1mm - 1.180 Kg/m



# MẶT DỰNG HỆ 100

Loại 4

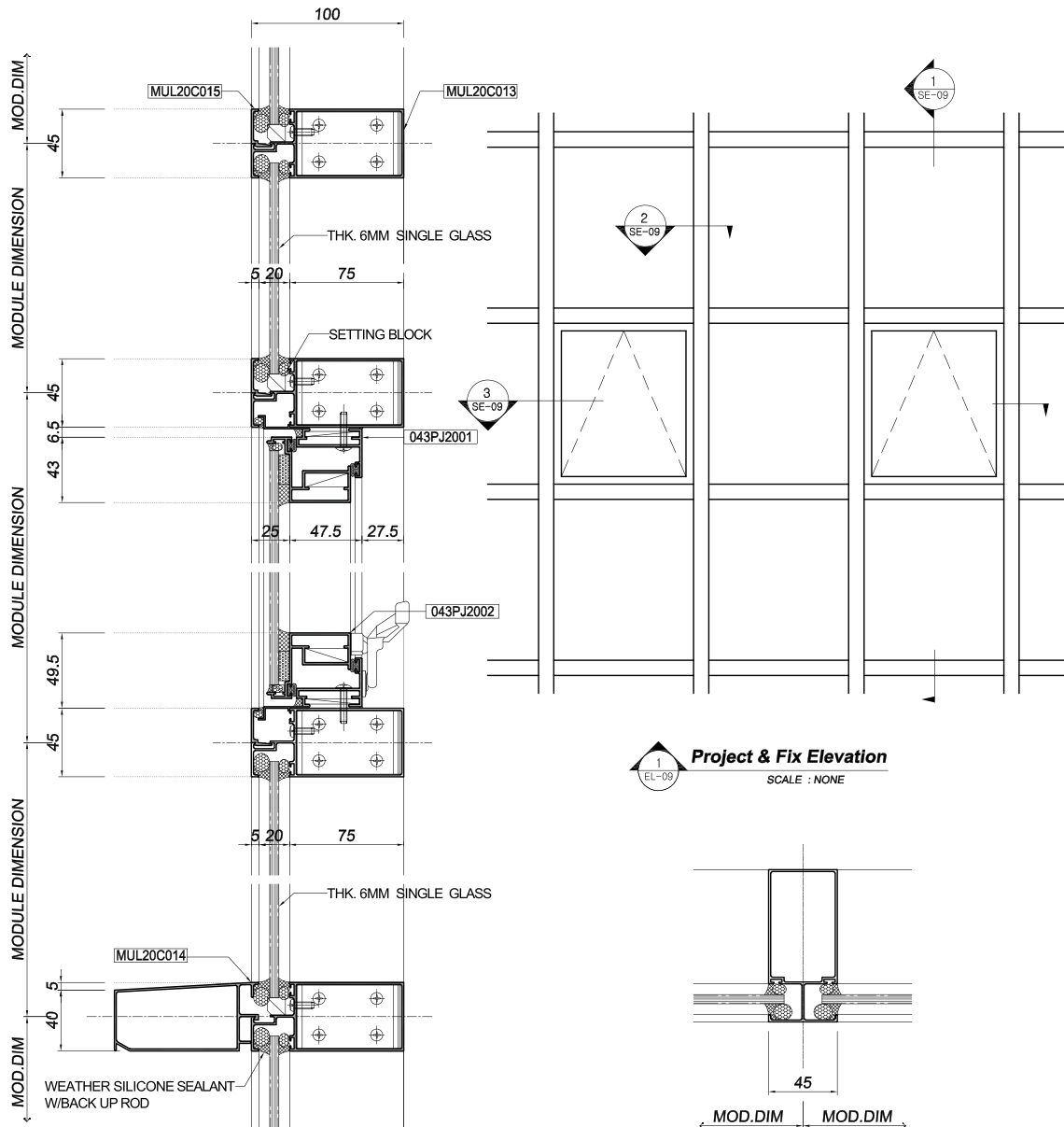

**Vertical Section Detail**  
SCALE : NONE

**Horizontal Section Detail**  
SCALE : NONE

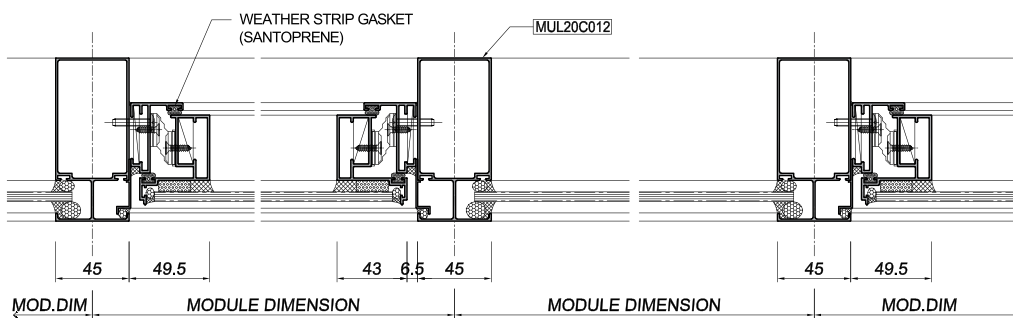

**Horizontal Section Detail**  
SCALE : NONE

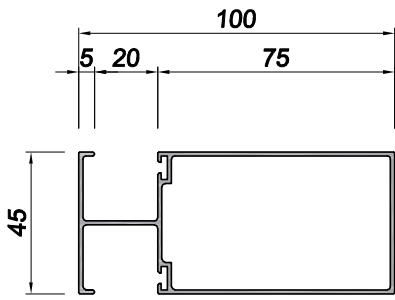

**MUL20C012**  
THK. 1.3mm - 1.144 Kg/m

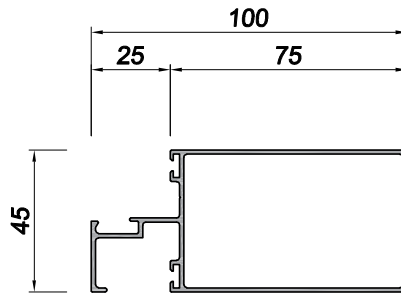

**MUL20C013**  
THK. 1.3mm - 1.091 Kg/m

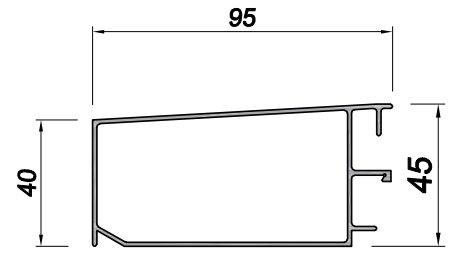

**MUL20C014**  
THK. 1.3mm - 1.033 Kg/m

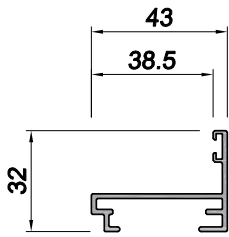

**043PJ2001**  
THK. 1.5mm - 0.455 Kg/m

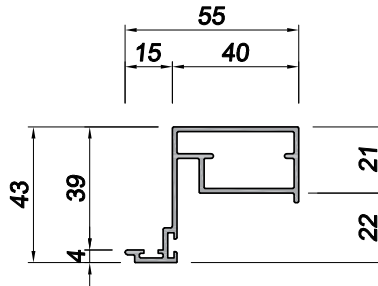

**043PJ2002**  
THK. 1.5mm - 0.743 Kg/m

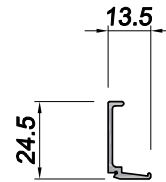

**MUL20C015**  
THK. 1.3mm - 0.155 Kg/m

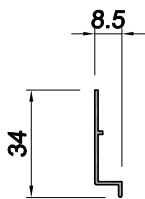

**MUL20C016**  
THK. 1.0mm - 0.116 Kg/m

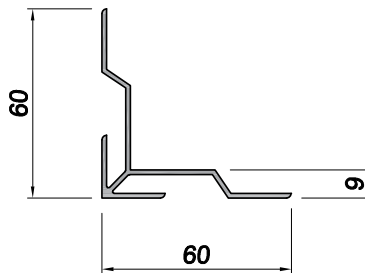

**060CP0009**  
THK. 1.5mm - 0.641 Kg/m

# MẶT DỰNG HỆ 120

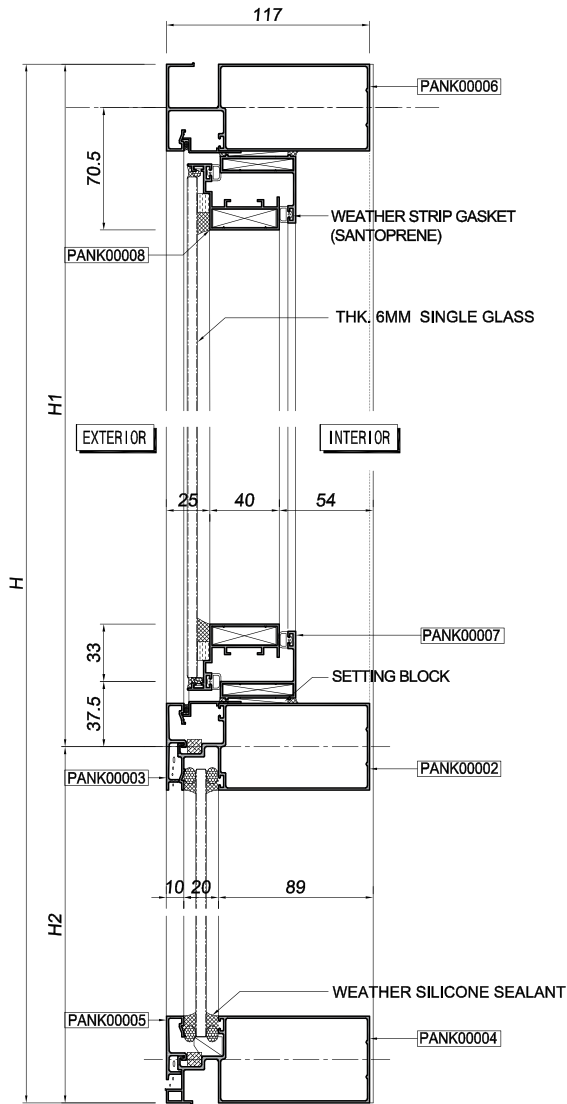

**1** SE-10  
**Vertical Section Detail**  
SCALE : NONE

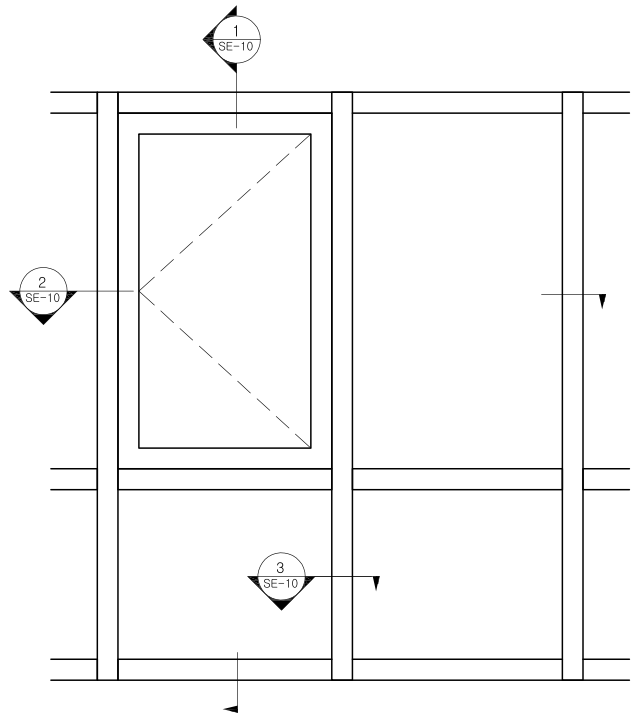

**1** EL-09  
**Project & Fix Elevation**  
SCALE : NONE

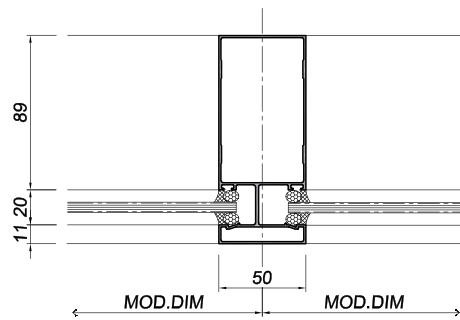

**3** SD-10  
**Horizontal Section Detail**  
SCALE : NONE

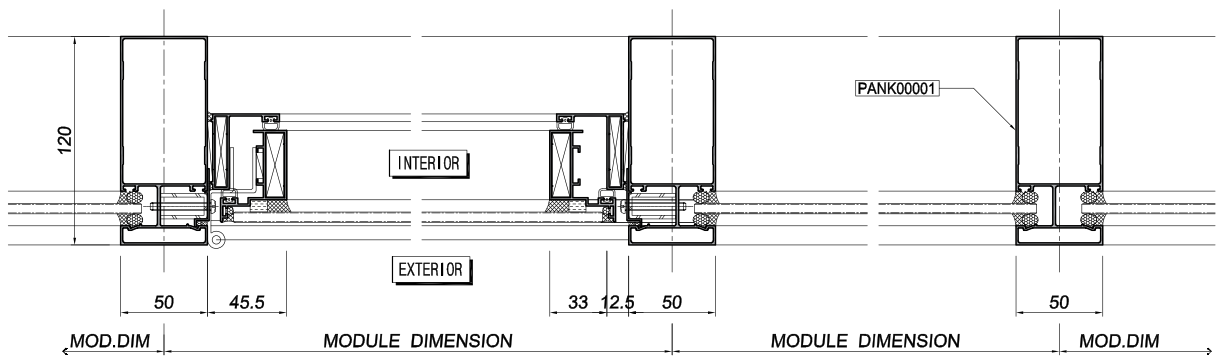

**2** SE-10  
**Horizontal Section Detail**  
SCALE : NONE



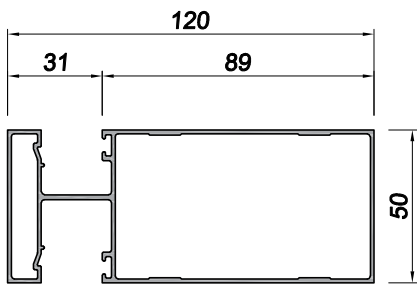

**PANK00001**  
THK. 1.2mm - 1.481 Kg/m

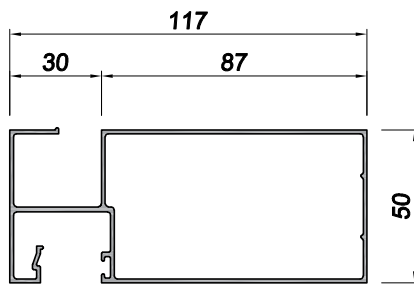

**PANK00006**  
THK. 1.2mm - 1.334 Kg/m

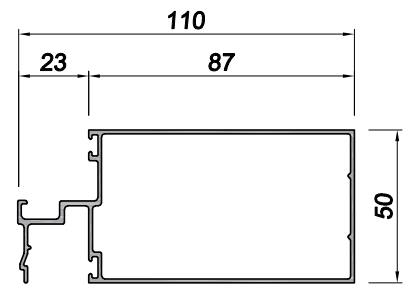

**PANK00002**  
THK. 1.2mm - 1.170 Kg/m

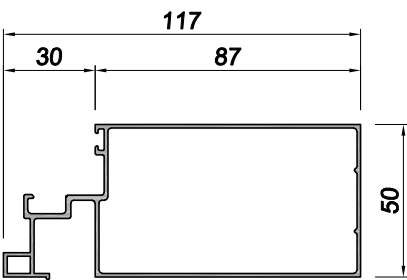

**PANK00004**  
THK. 1.2mm - 1.234 Kg/m

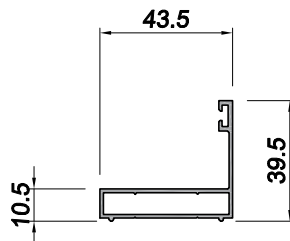

**PANK00007**  
THK. 1.2mm - 0.476 Kg/m

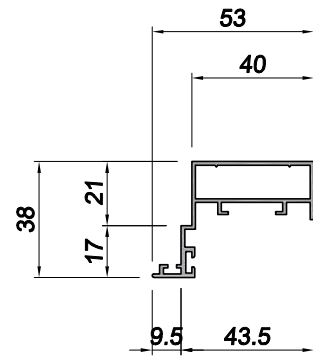

**PANK00008**  
THK. 1.2mm - 0.574 Kg/m

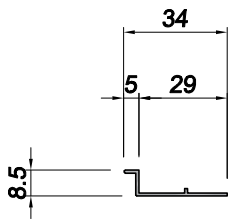

**MUL20C016**  
THK. 1.0 mm - 0.116 Kg/m

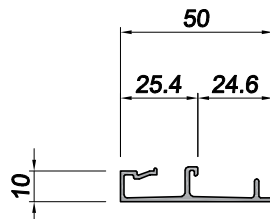

**PANK00003**  
THK. 1.2mm - 0.351 Kg/m

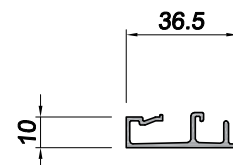

**PANK00005**  
THK. 1.2mm - 0.302Kg/m

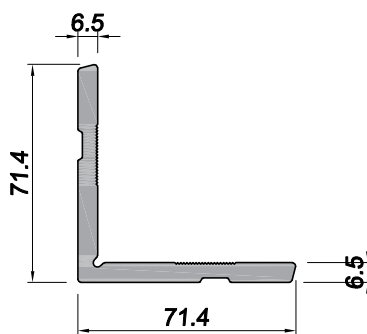

**035P19115**  
THK. 6.5mm - 2.263 Kg/m

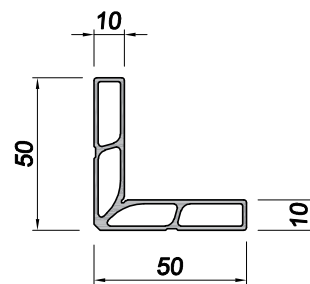

**EX0000112**  
THK. 1.4mm - 0.853 Kg/m

# MẶT DỰNG HỆ 130

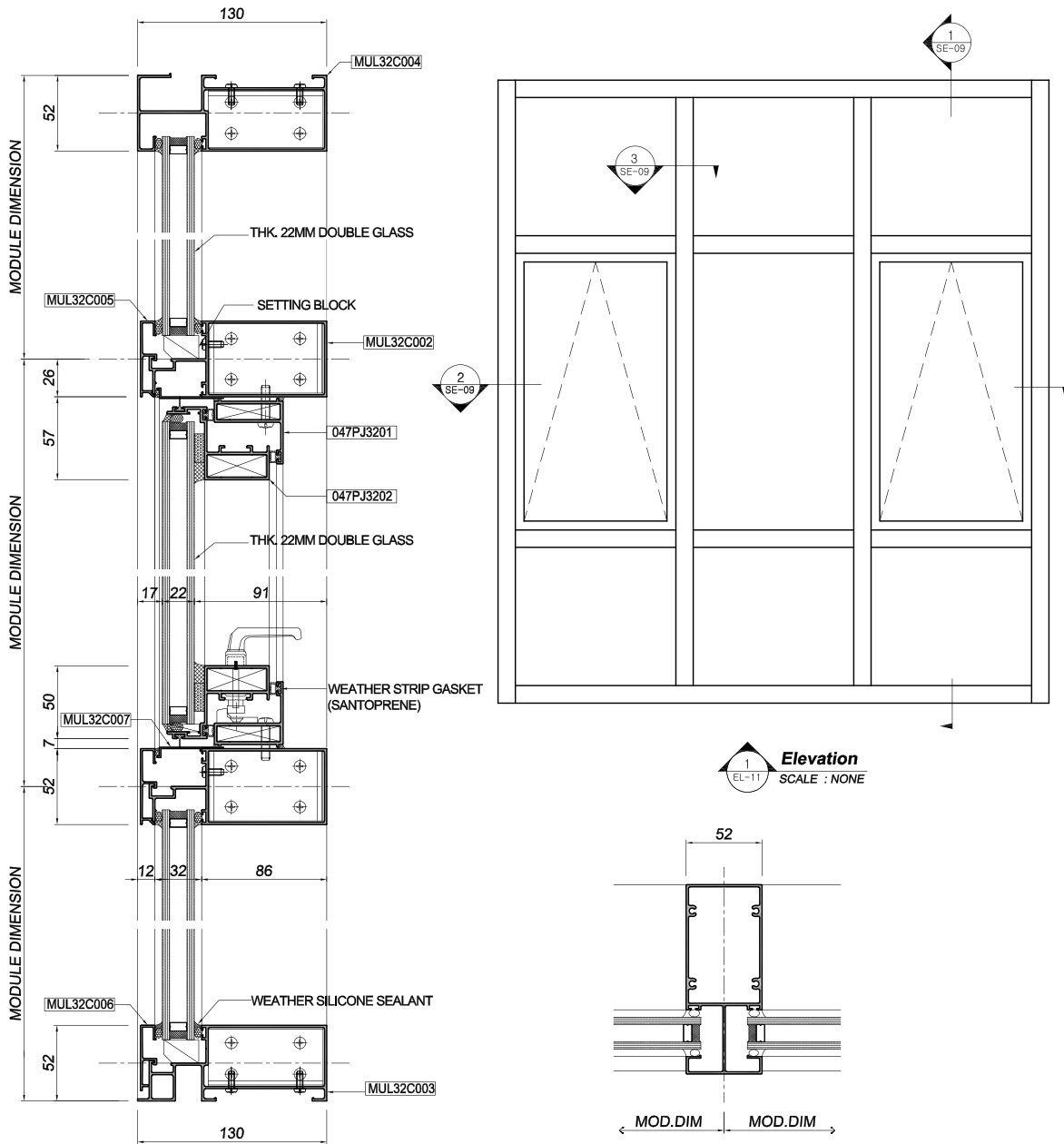

**1** Vertical Section Detail  
SCALE : NONE

**3** Horizontal Section Detail  
SCALE : NONE

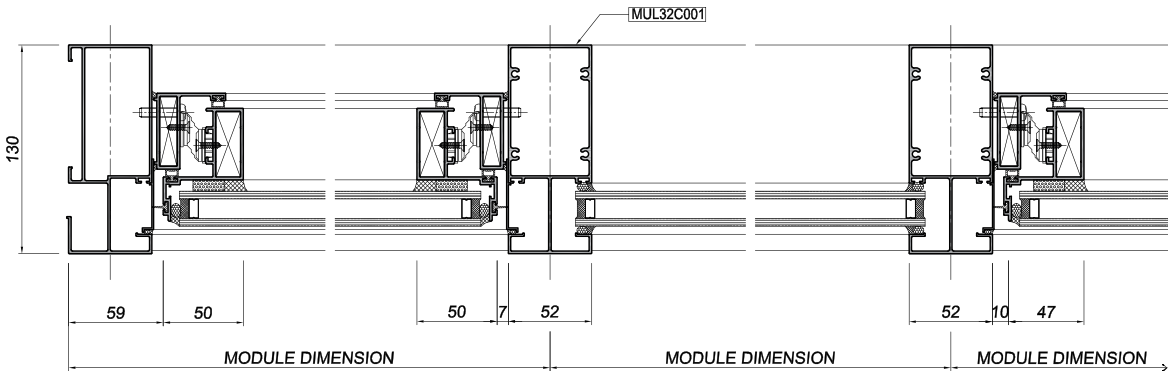

**2** Horizontal Section Detail  
SCALE : NONE

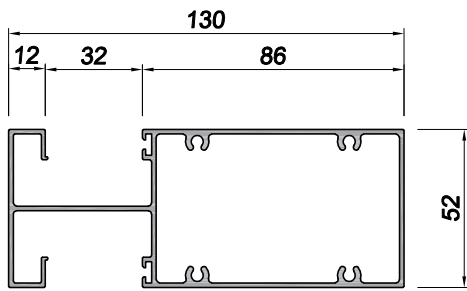

**MUL32C001**  
THK. 1.5mm - 1.948 Kg/m

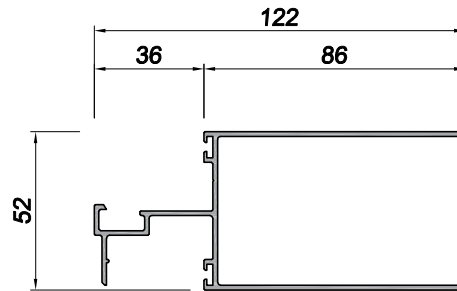

**MUL32C002**  
THK. 1.5mm - 1.449 Kg/m

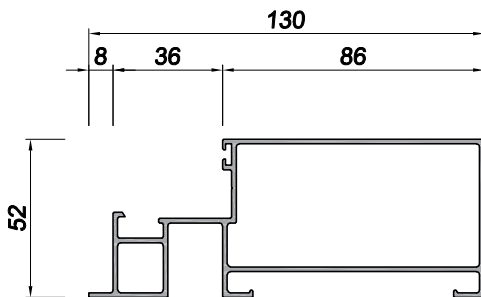

**MUL32C003**  
THK. 1.5mm - 1.677 Kg/m

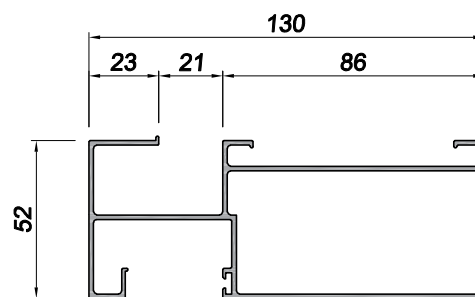

**MUL32C004**  
THK. 1.5mm - 1.763 Kg/m

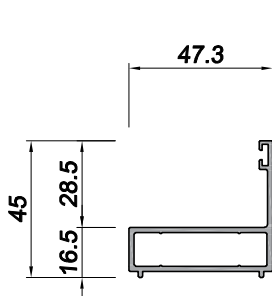

**047PJ3201**  
THK. 1.7mm - 0.720 Kg/m

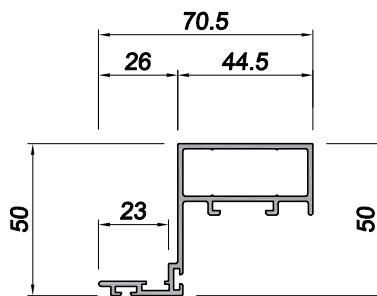

**047PJ3202**  
THK. 1.7mm - 0.962 Kg/m

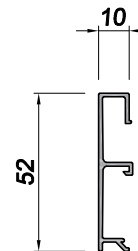

**MUL32C005**  
THK. 1.2mm - 0.334 Kg/m

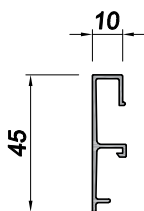

**MUL32C006**  
THK. 1.2mm - 0.285 Kg/m

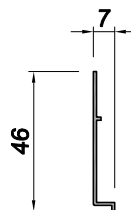

**MUL32C007**  
THK. 1.2mm - 0.145 Kg/m

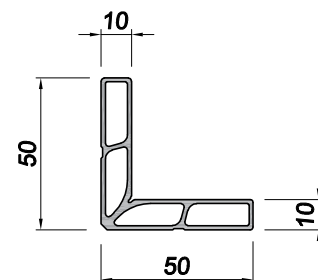

**EX0000112**  
THK. 1.4mm - 0.853 Kg/m

# MẶT DỰNG HỆ 135

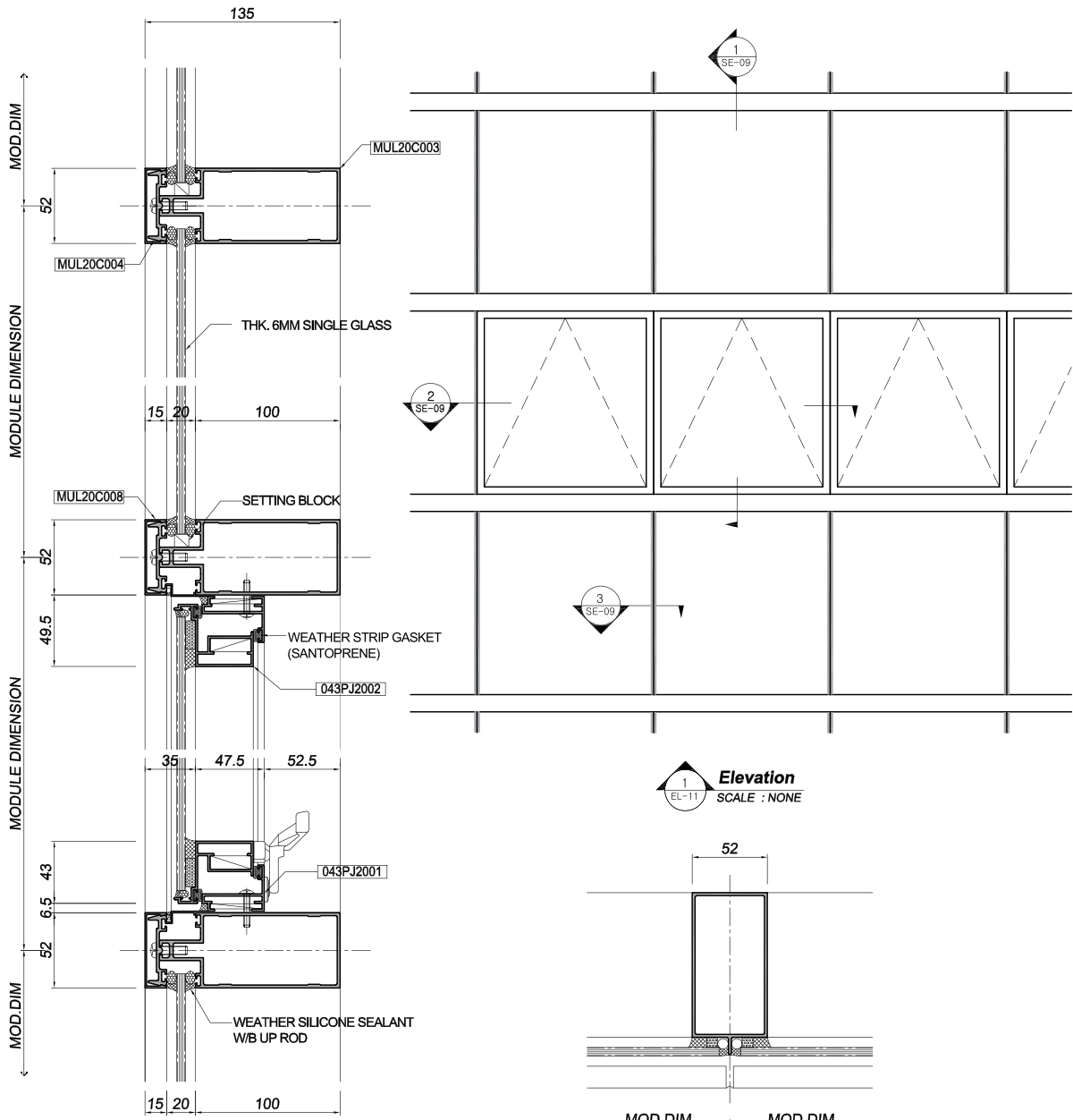

**1 Vertical Section Detail**  
SCALE : NONE

**1 Elevation**  
SCALE : NONE

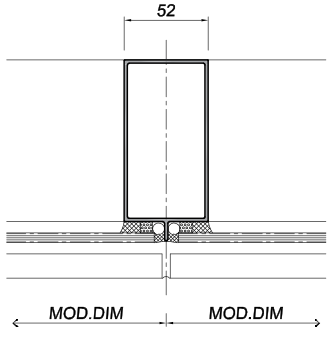

**3 Horizontal Section Detail**  
SCALE : NONE

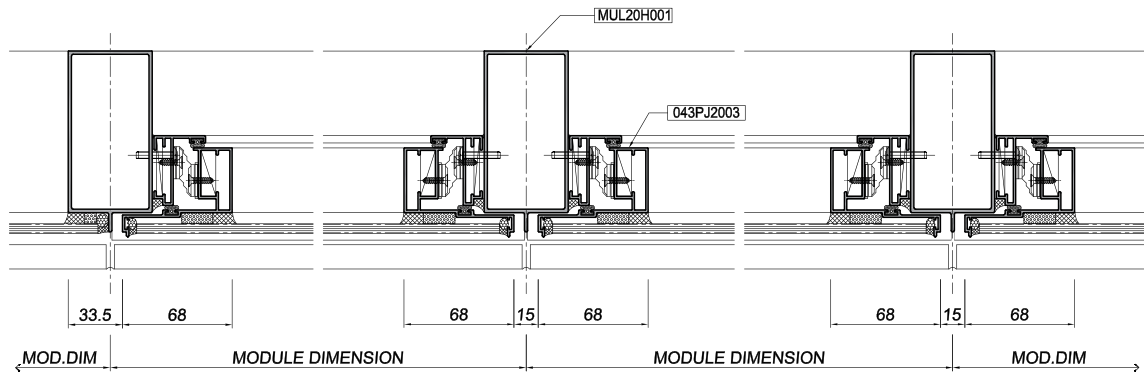

**2 Horizontal Section Detail**  
SCALE : NONE

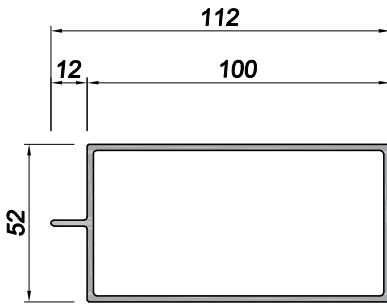

**MUL20H001**  
THK. 2.0mm - 1.671 Kg/m

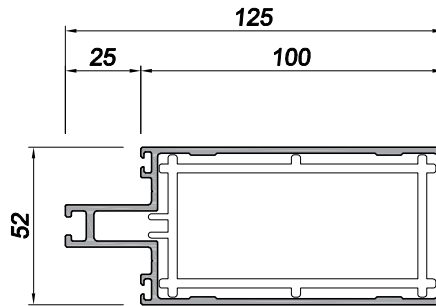

**MUL20C003**  
THK. 2.0mm - 2.050 Kg/m

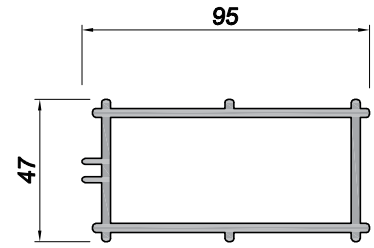

**MUL20C011**  
THK. 3.0mm - 2.260 Kg/m

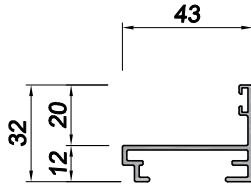

**043PJ2001**  
THK. 1.5mm - 0.455 Kg/m

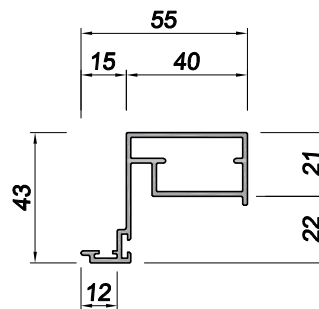

**043PJ2002**  
THK. 1.5mm - 0.743 Kg/m

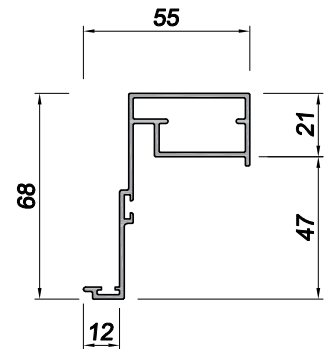

**043PJ2003**  
THK. 1.5mm - 0.845 Kg/m

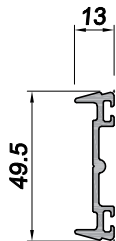

**MUL20C004**  
THK. 2.0mm - 0.490Kg/m

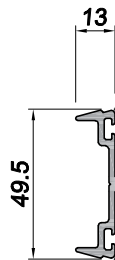

**MUL25C001**  
THK. 2.0mm - 0.482 Kg/m

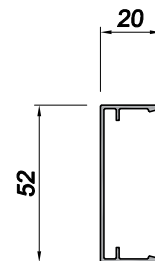

**MUL20C007**  
THK. 1.2mm - 0.325Kg/m

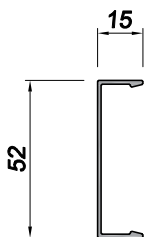

**MUL20C008**  
THK. 1.2mm - 0.271 Kg/m

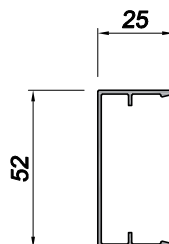

**MUL20C009**  
THK. 1.2mm - 0.357 Kg/m

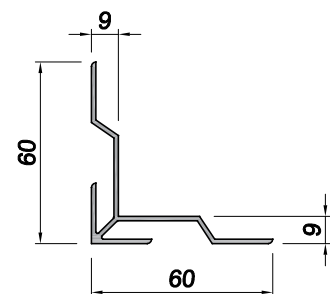

**060CP0009**  
THK. 1.5mm - 0.641 Kg/m

# MẶT DỰNG HỆ 145 (SEVT)

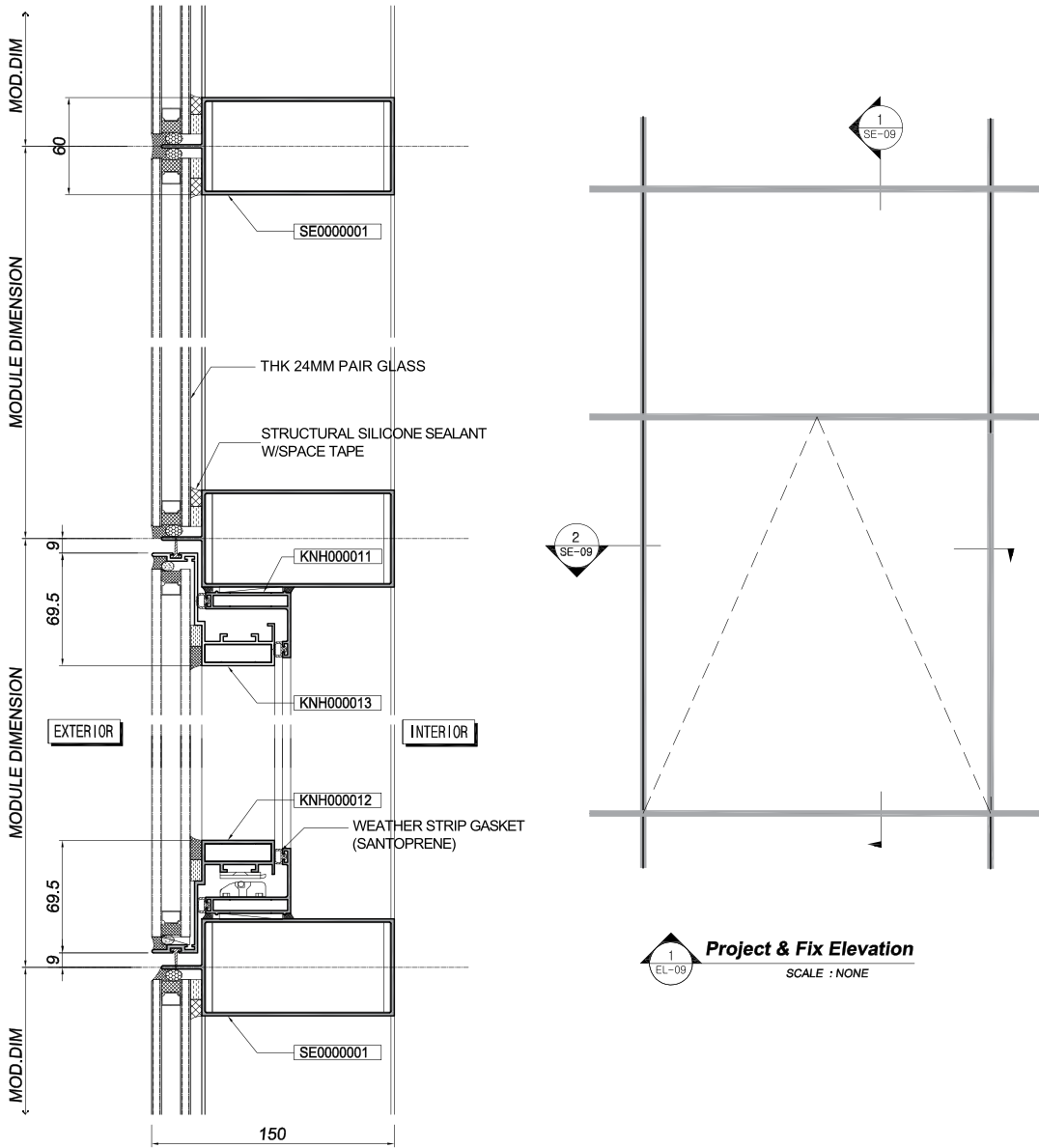

**Vertical Section Detail**  
SCALE : NONE

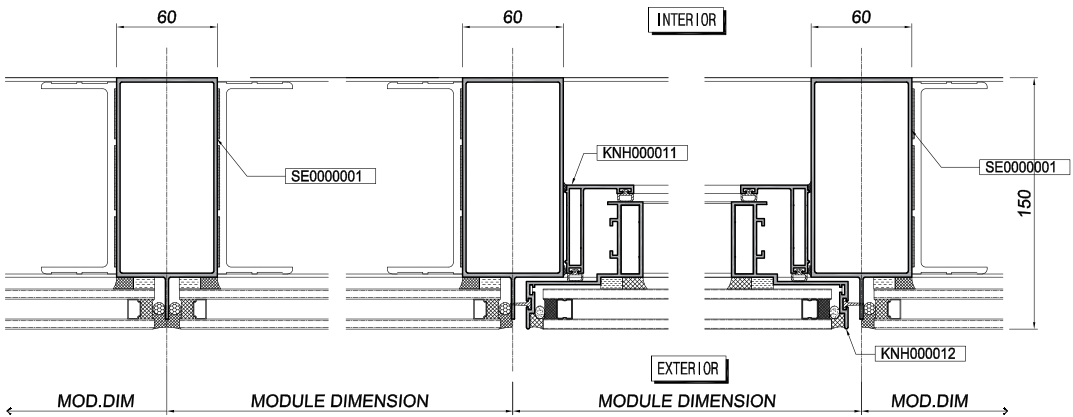

**Horizontal Section Detail**  
SCALE : NONE



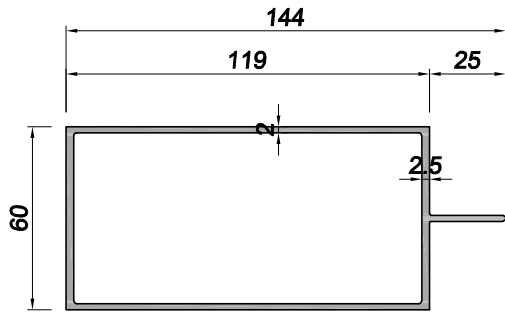

**SE0000001**  
THK. 2.0mm - 2.188 Kg/m

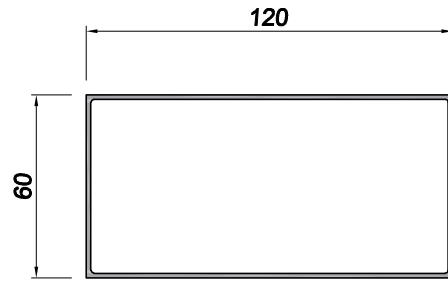

**SE0000002**  
THK. 1.5mm - 1.441 Kg/m

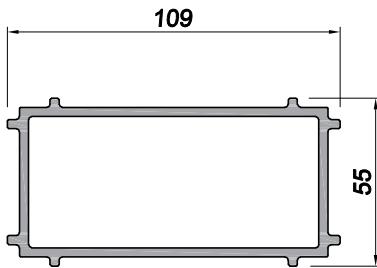

**VNH000009**  
THK. 3mm - 2.578 Kg/m

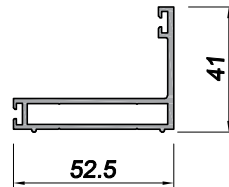

**KNH000011**  
THK. 2mm - 0.736 Kg/m

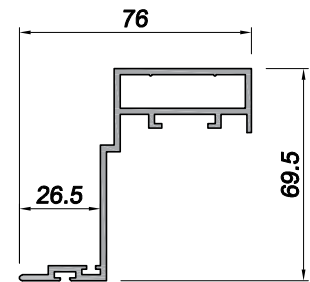

**KNH000012**  
THK. 2mm - 1.217 Kg/m

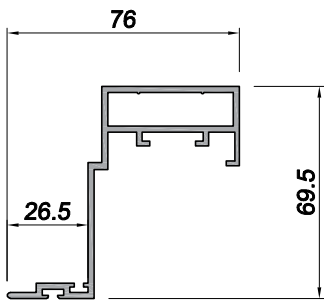

**KNH000013**  
THK. 2mm - 1.248 Kg/m

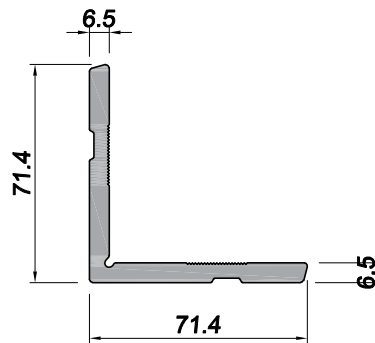

**035P19115**  
THK. 6.5mm - 2.263 Kg/m

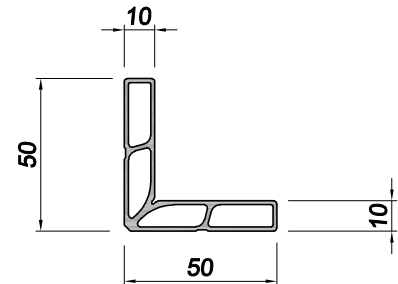

**EX0000112**  
THK. 1.4mm - 0.853 Kg/m

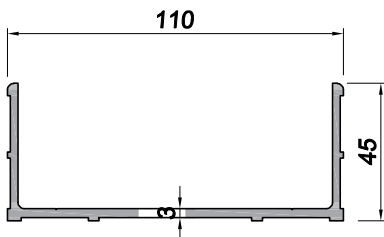

**VNH000008**  
THK. 3mm - 1.525 Kg/m

# MẶT DỰNG HỆ 150

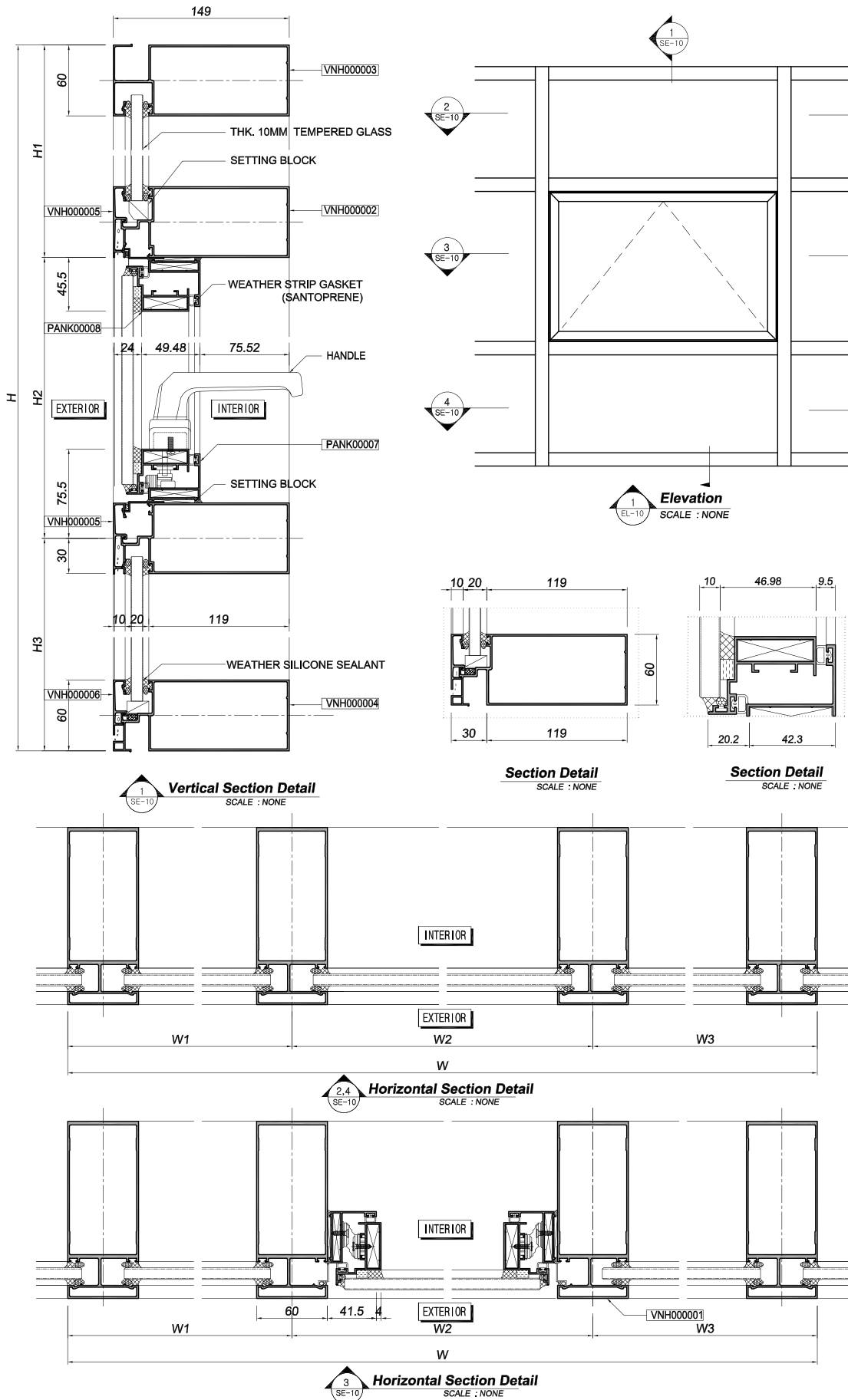

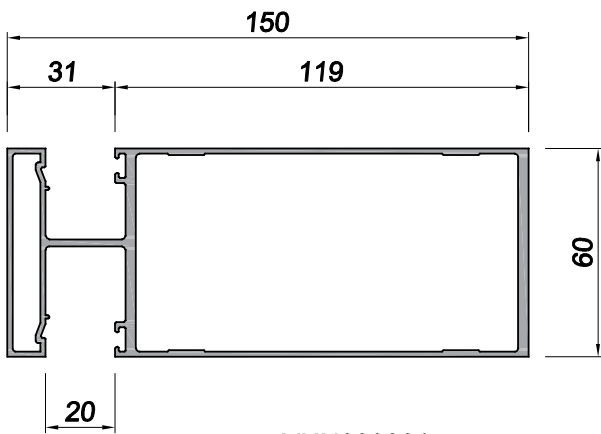

**VNH000001**  
THK. 1.5 mm - 2.681 Kg/m

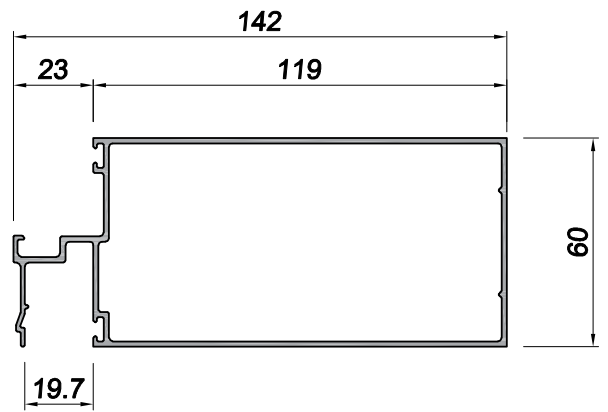

**VNH000002**  
THK. 1.5 mm - 1.734 Kg/m

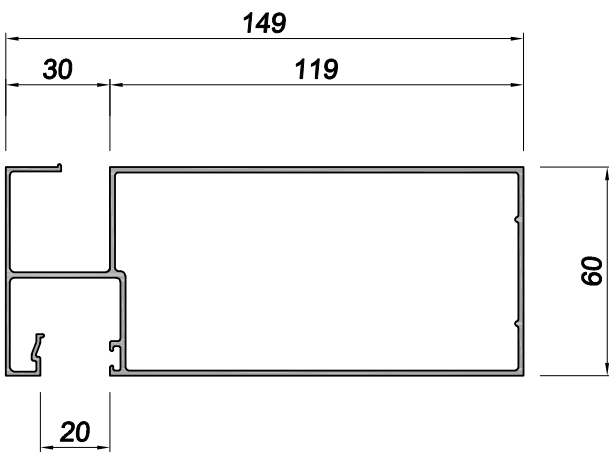

**VNH000003**  
THK. 1.5 mm - 1.922 Kg/m

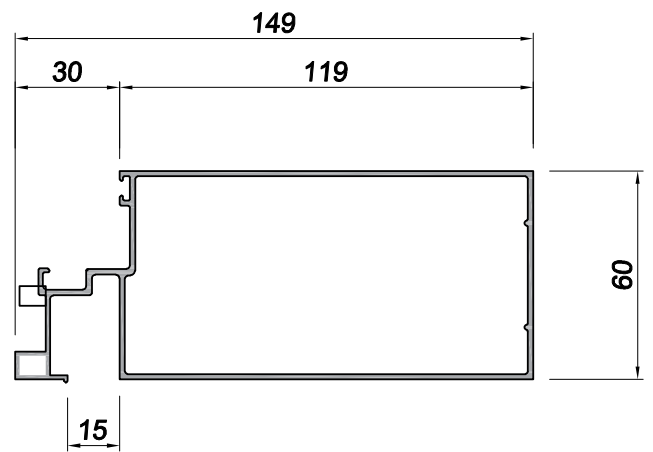

**VNH000004**  
THK. 1.5 mm - 1.919 Kg/m

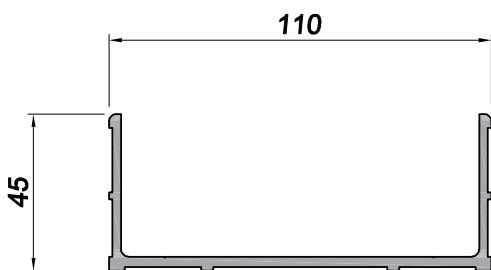

**VNH000008**  
THK. 3.0 mm - 1.525 Kg/m

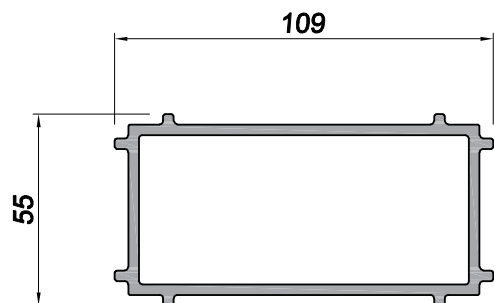

**VNH000009**  
THK. 3.0 mm - 2.578 Kg/m

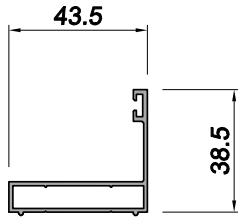

**PANK00007**  
THK. 1.2 mm - 0.476 Kg/m

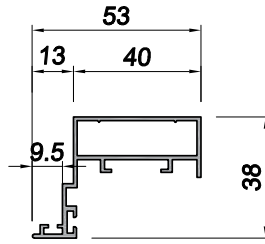

**PANK00008**  
THK. 1.2 mm - 0.574 Kg/m

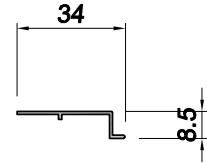

**MUL20C016**  
THK. 1.0 mm - 0.116 Kg/m

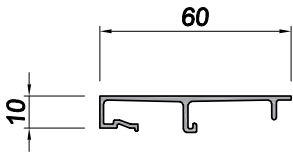

**VNH000005**  
THK. 1.2 mm - 0.383 Kg/m

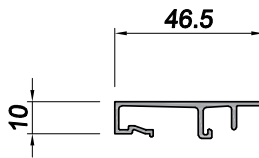

**VNH000006**  
THK. 1.2 mm - 0.335 Kg/m

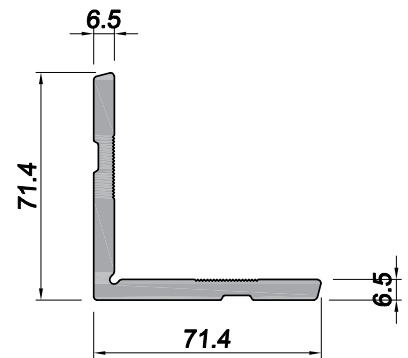

**035P19115**  
THK. 6.5mm - 2.263 Kg/m

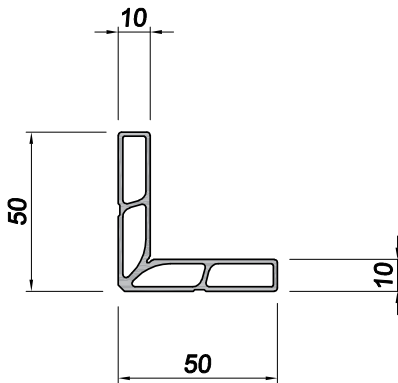

**EX0000112**  
THK. 1.4mm - 0.853 Kg/m

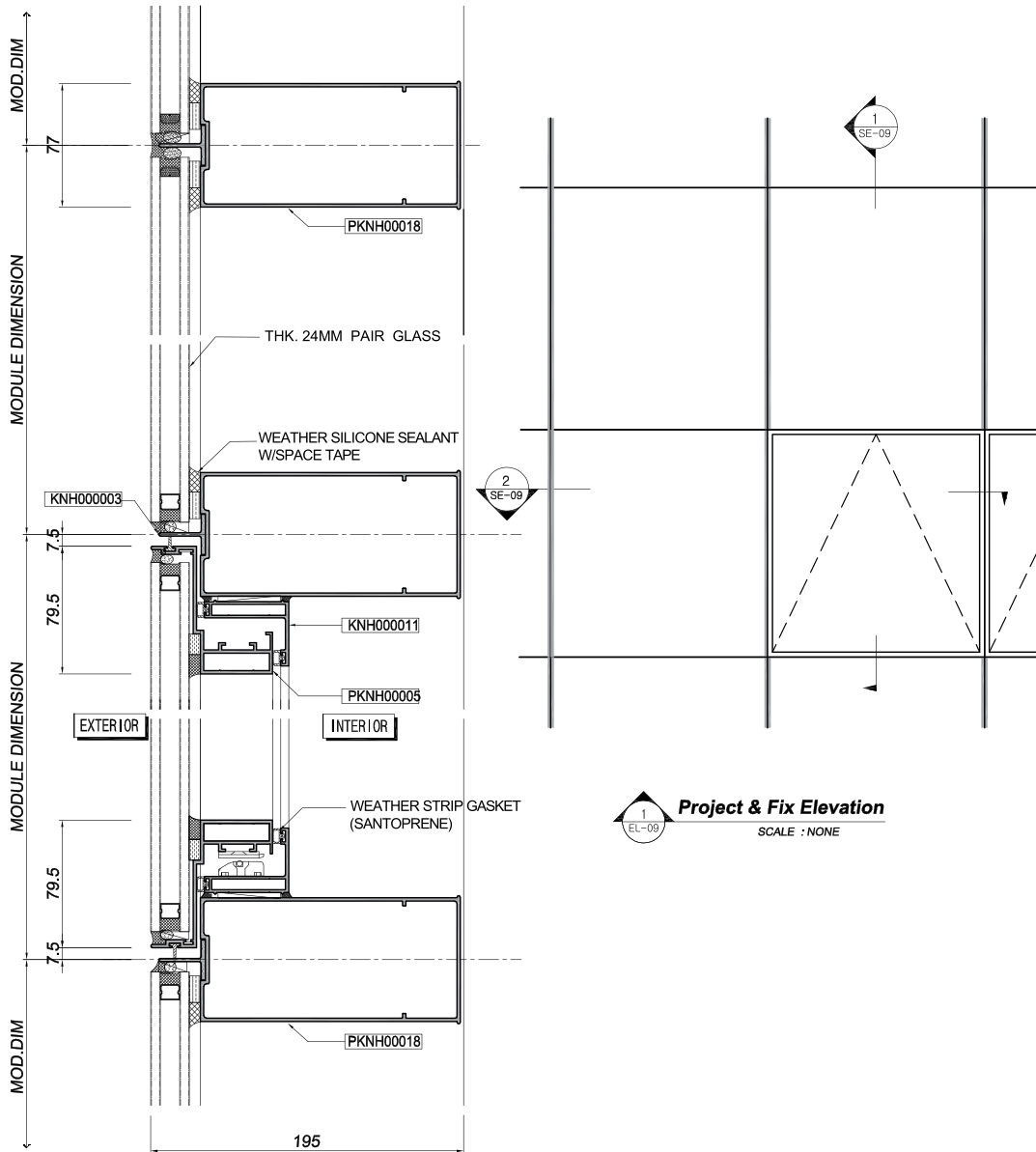

**Project & Fix Elevation**  
SCALE : NONE

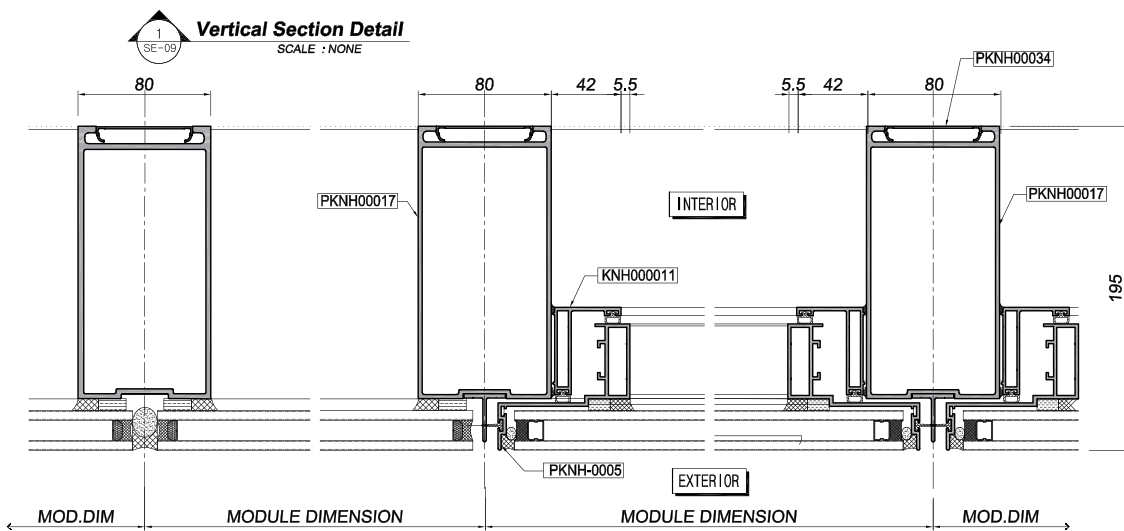

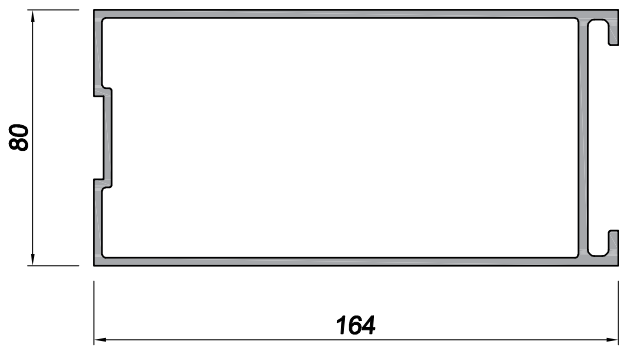

**PKNH00017**  
THK. 2.5mm - 3.549 Kg/m

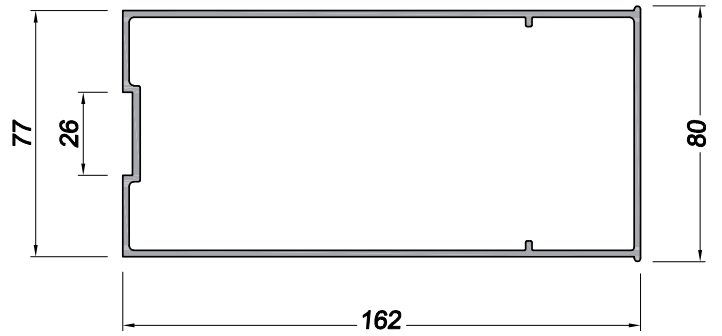

**PKNH00018**  
THK. 2.5mm - 2.674 Kg/m

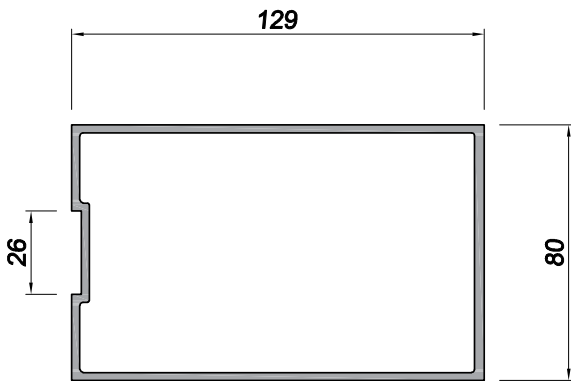

**PKNH00001**  
THK. 3mm - 2.910 Kg/m

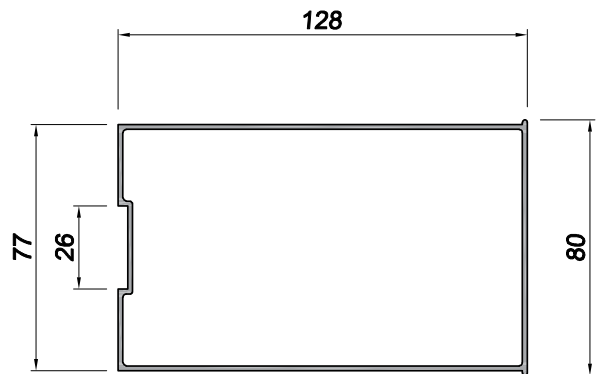

**PKNH00002**  
THK. 1.5mm - 1.681 Kg/m

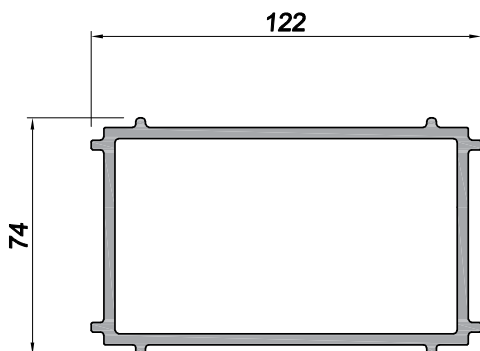

**PKNH00003**  
THK. 3.5 mm - 3.566 Kg/m

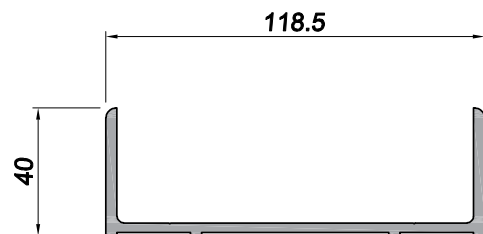

**PKNH00004**  
THK. 3.5mm - 1.678 Kg/m



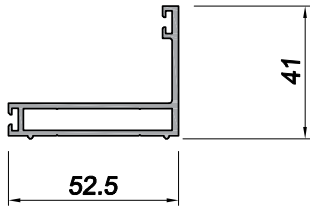

**KNH000011**  
THK. 2.0 mm - 0.737 Kg/m

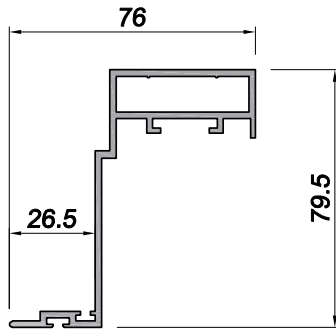

**PKNH000005**  
THK. 2.0 mm - 1.271 Kg/m

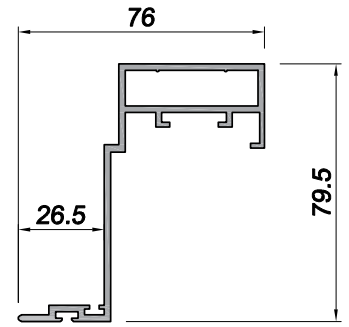

**PKNH000006**  
THK. 2.0 mm - 1.302 Kg/m

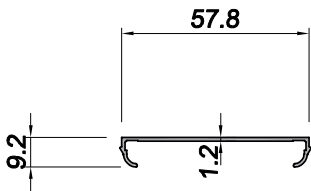

**PKNH000034**  
THK. 1.2 mm - 0.243 Kg/m

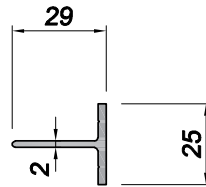

**KNH000003**  
THK. 2.0 mm - 0.313 Kg/m

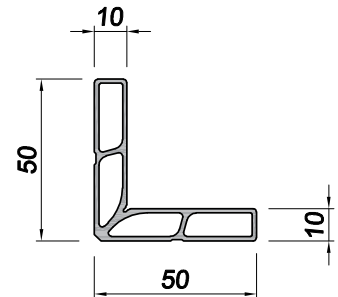

**EX0000112**  
THK. 1.4mm - 0.853 Kg/m

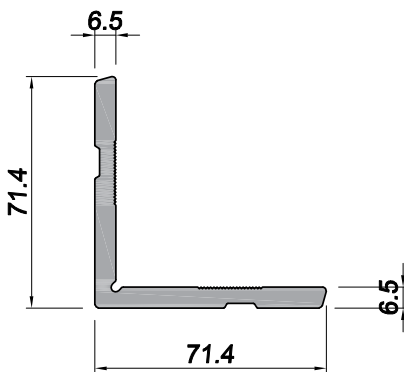

**035P19115**  
THK. 6.5mm - 2.263 Kg/m

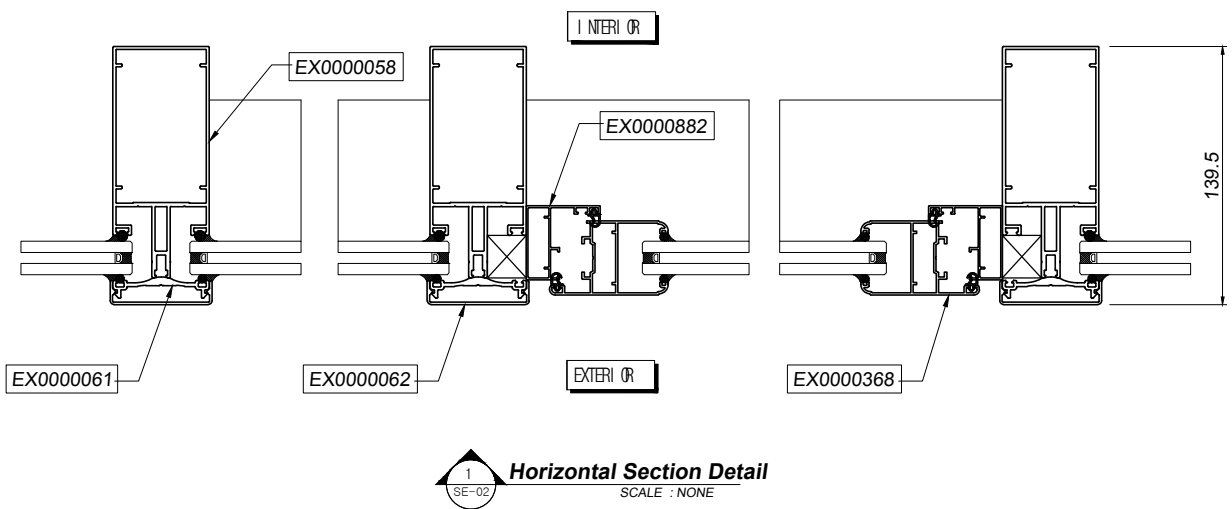
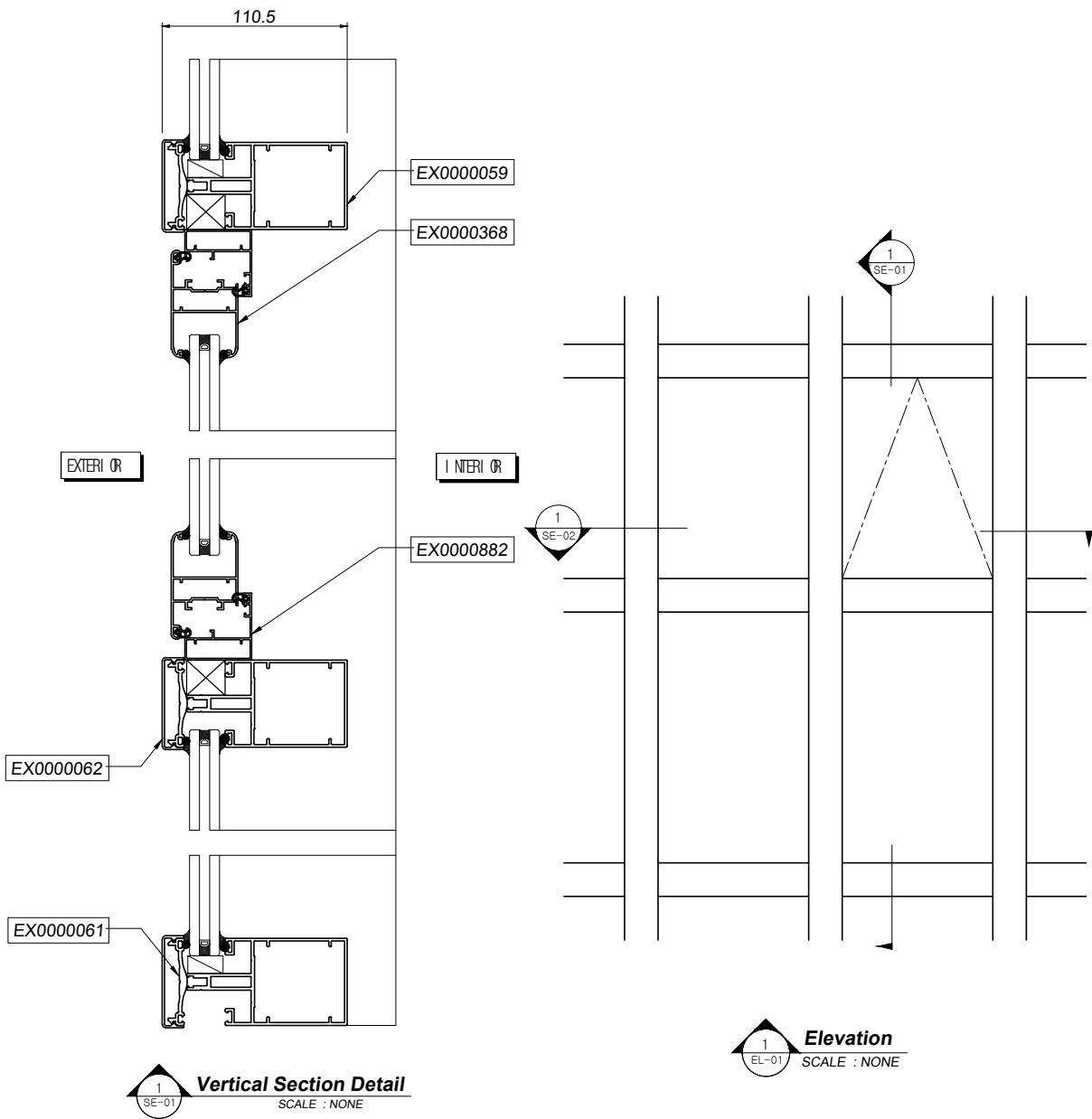

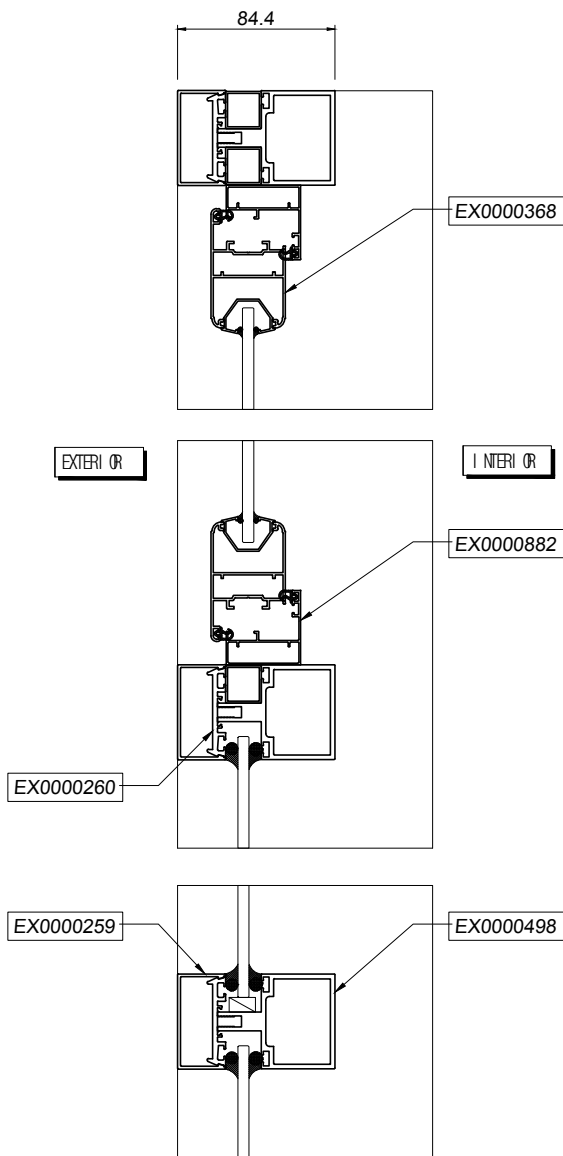

**Vertical Section Detail**  
SCALE : NONE

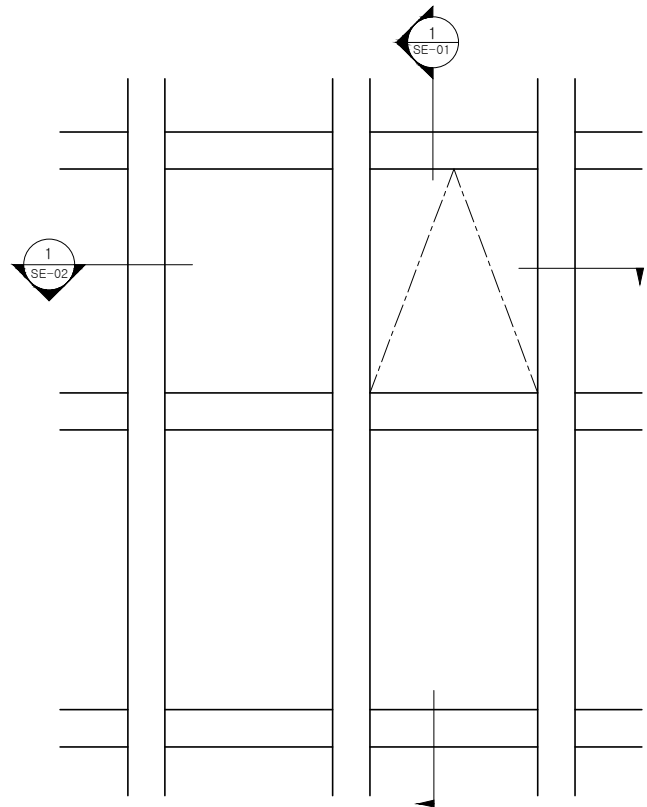

**Elevation**  
SCALE : NONE

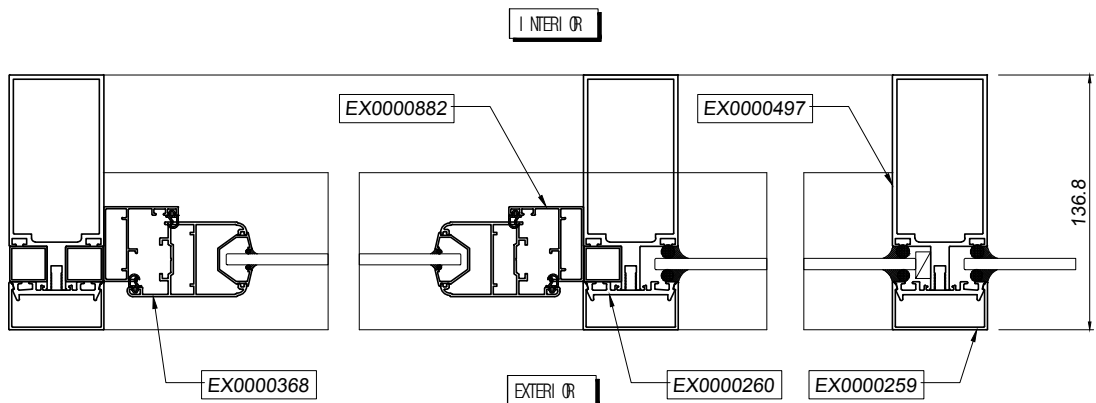

**Horizontal Section Detail**  
SCALE : NONE

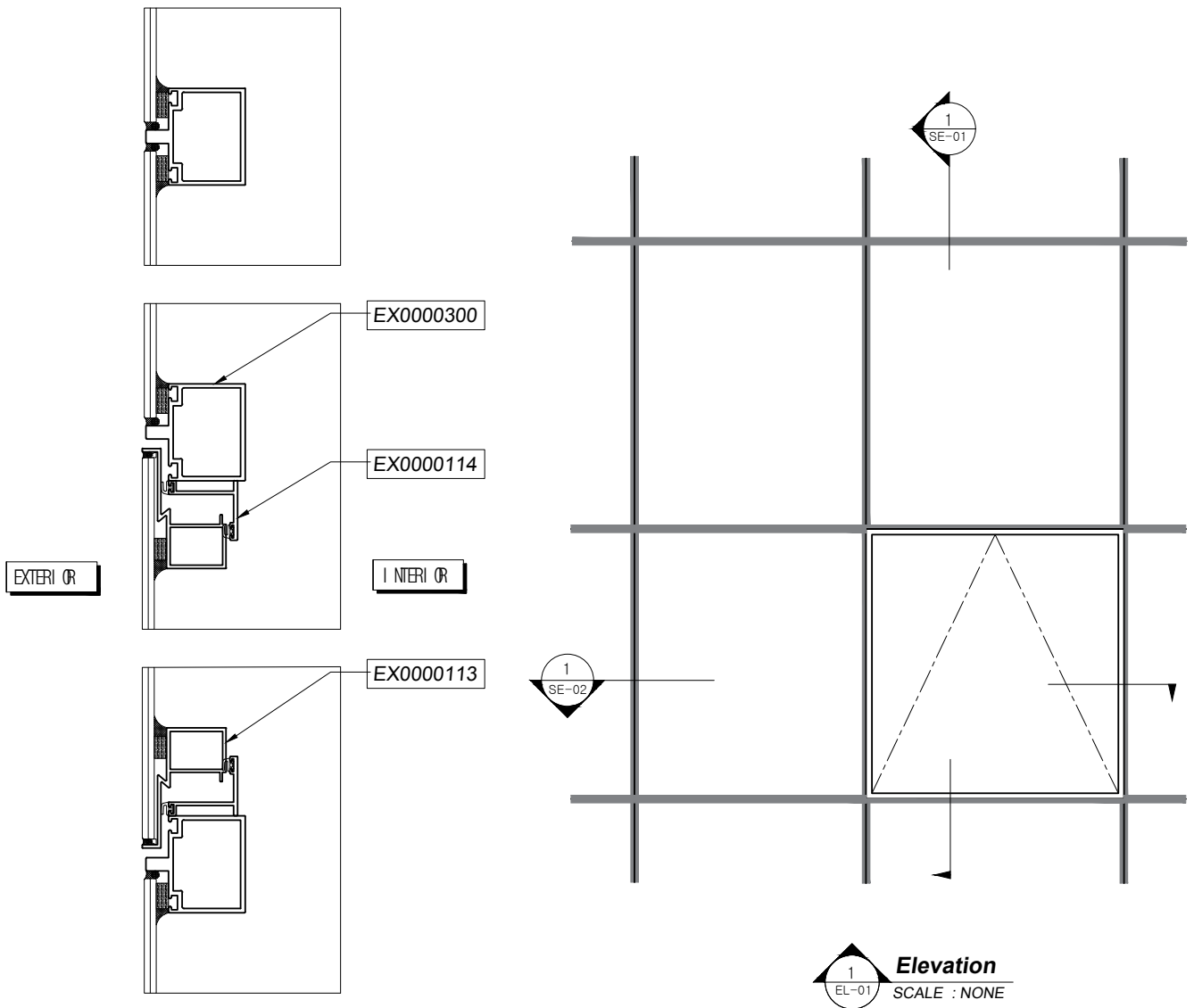

**Vertical Section Detail**  
SCALE: NONE

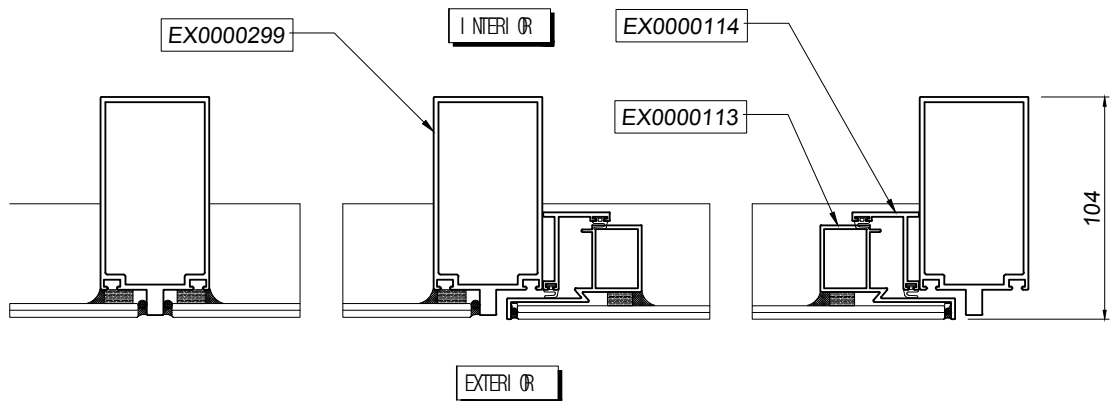

**Horizontal Section Detail**  
SCALE: NONE

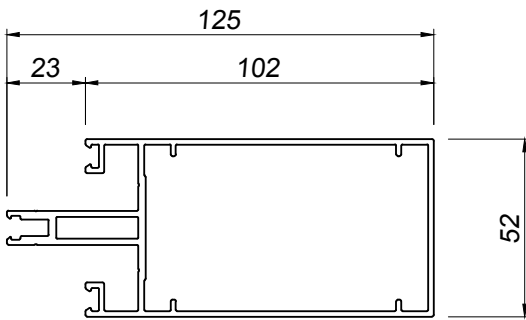

**EX0000058 (1101)**  
THK. 1.6 mm - 1.982 Kg/m

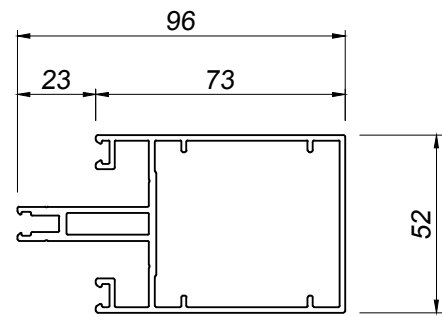

**EX0000059 (1108)**  
THK. 1.6 mm - 1.731 Kg/m

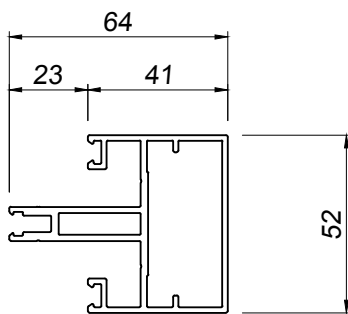

**EX0000060 (1136)**  
THK. 1.6 mm - 1.428 Kg/m

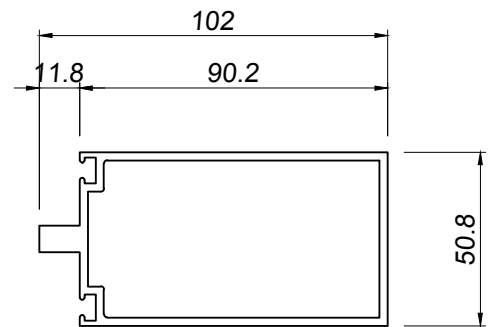

**EX0000299 (2748)**  
THK. 2.4 mm - 2.083 Kg/m

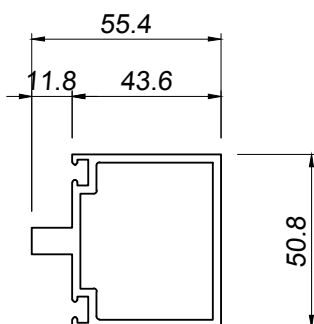

**EX0000300 (2749)**  
THK. 2.4 mm - 1.477 Kg/m

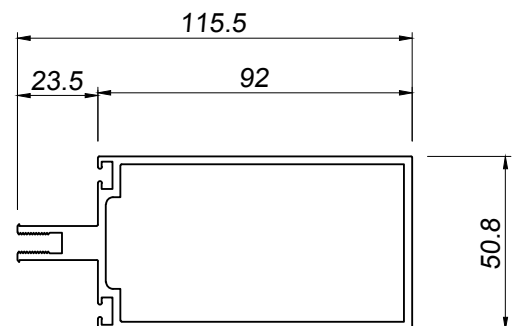

**EX00000497 (1065)**  
THK. 2.34 mm - 2.258 Kg/m

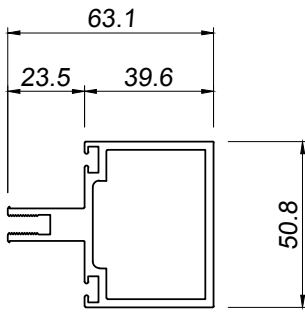

**EX0000498 (1068)**  
THK. 2.5 mm - 1.660 Kg/m

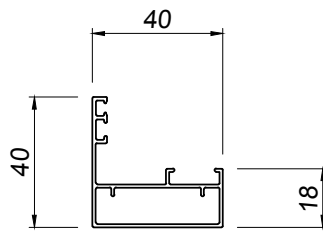

**EX0000882 (4402)**  
THK. 1.0 mm - 0.442 Kg/m

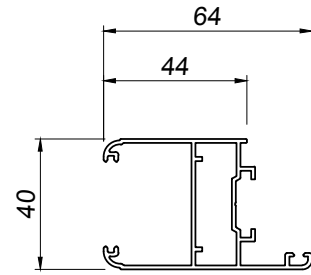

**EX0000368 (4410)**  
THK. 1.25 mm - 0.770 Kg/m

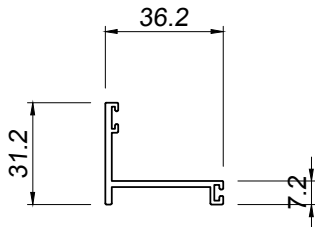

**EX0000114 (1401)**  
THK. 1.8 mm - 0.387 Kg/m

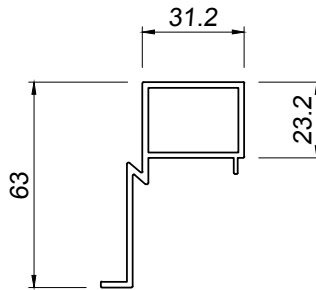

**EX0000113 (1402)**  
THK. 1.8 mm - 0.779 Kg/m

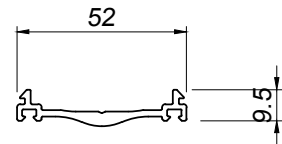

**EX0000061 (1104)**  
THK. 2.0 mm - 0.461 Kg/m

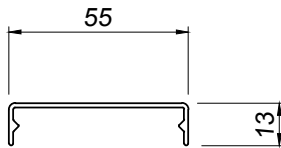

**EX0000062 (1105)**  
THK. 1.3 mm - 0.289 Kg/m

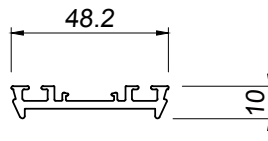

**EX0000260 (1067)**  
THK. 2.5 mm - 0.494 Kg/m

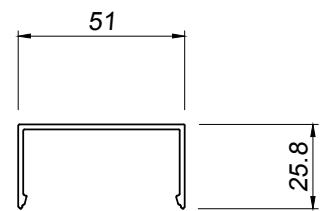

**EX0000259 (1066)**  
THK. 1.5 mm - 0.414 Kg/m



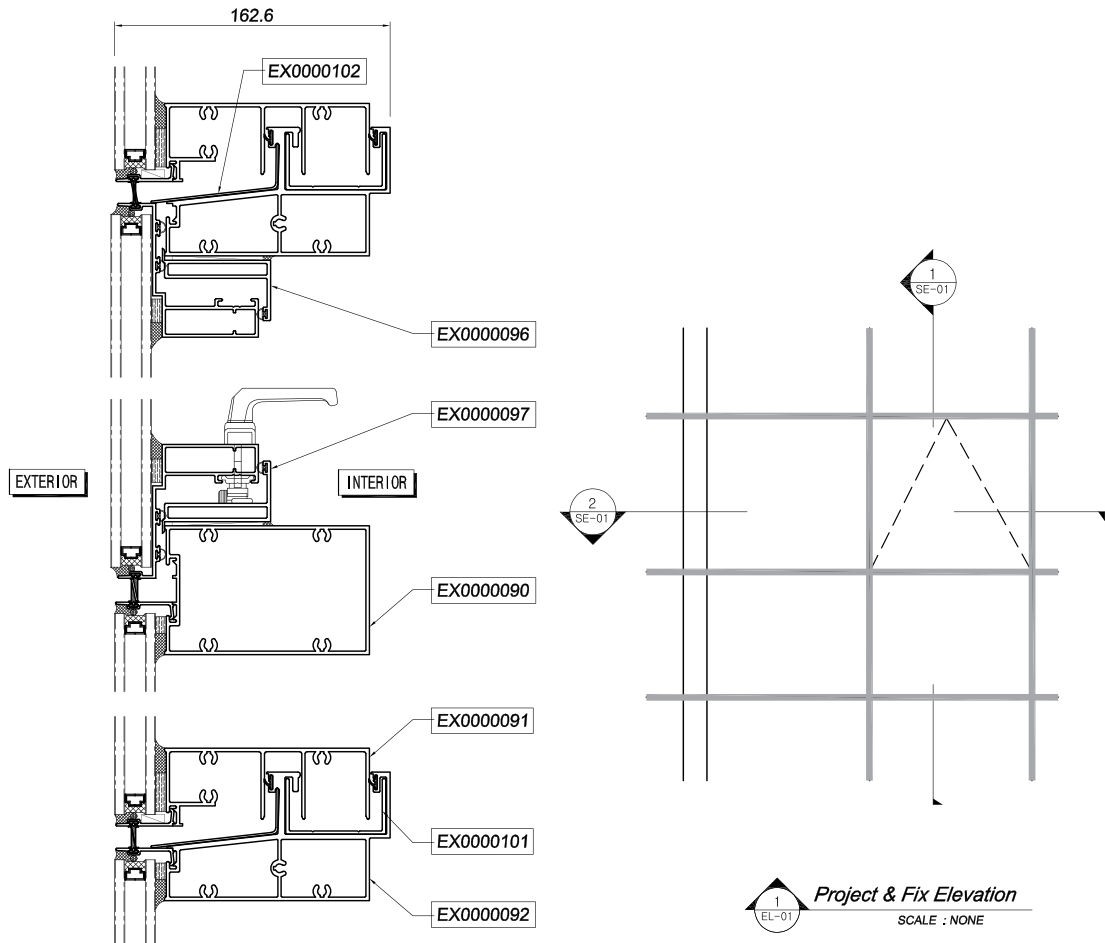

1 SE-01 Vertical Section Detail  
SCALE : NONE

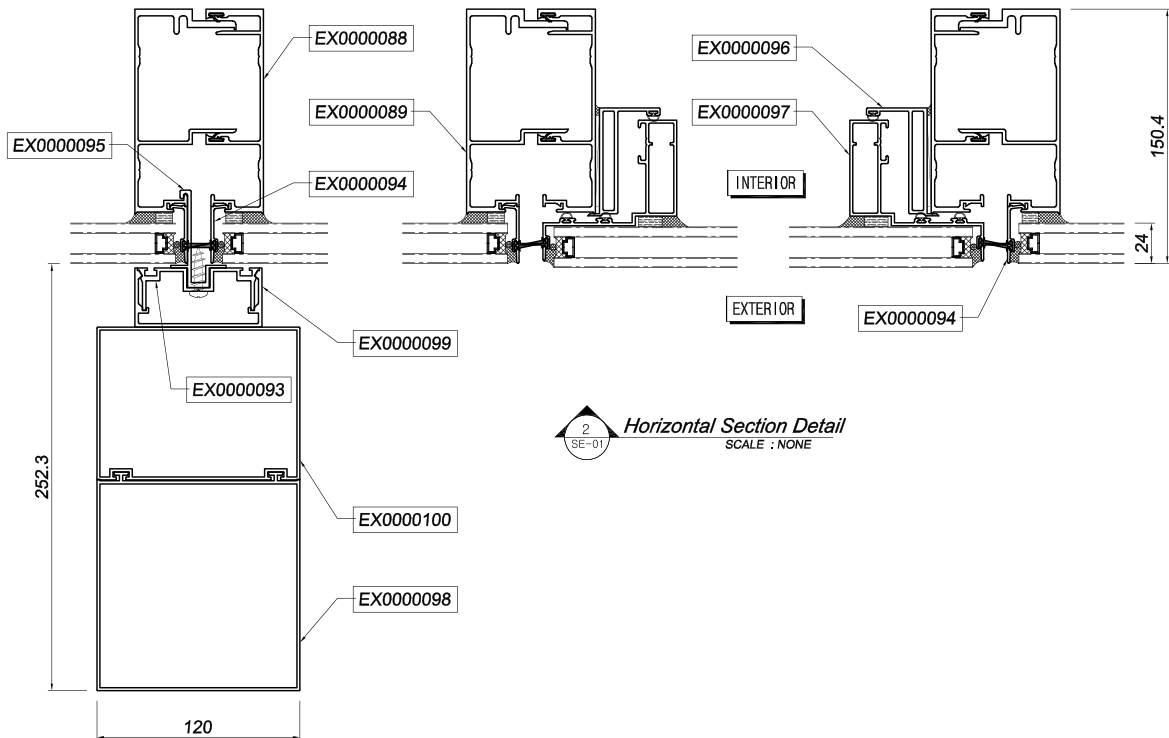

2 SE-01 Horizontal Section Detail  
SCALE : NONE

# MẶT DUNG HỆ 160 (UNIT)

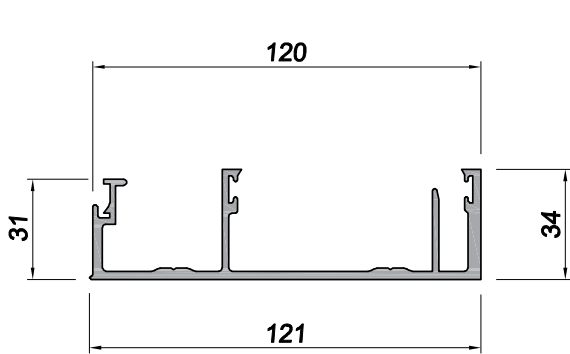

**EX0000088**  
THK. 2.5 mm - 1.828 Kg/m

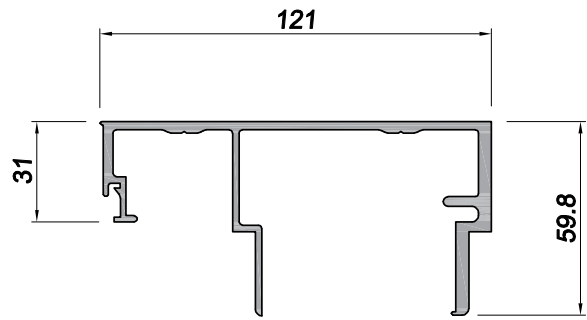

**EX0000089**  
THK. 2.5 mm - 2.254 Kg/m

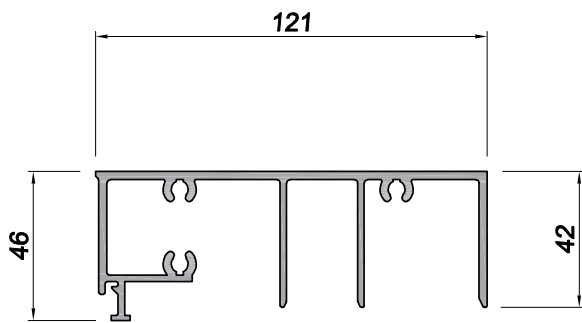

**EX0000091**  
THK. 2.5 mm - 2.28 Kg/m

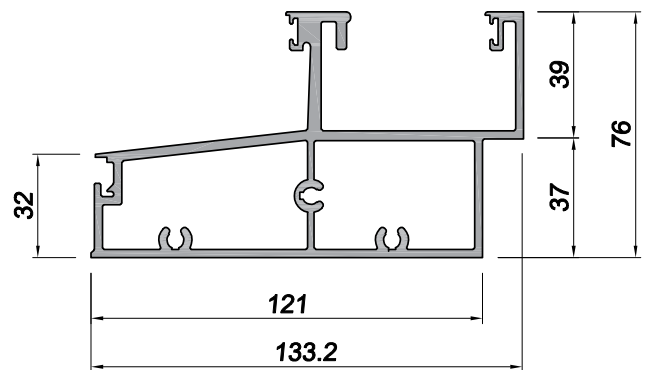

**EX0000092**  
THK. 2.5 mm - 3.836 Kg/m

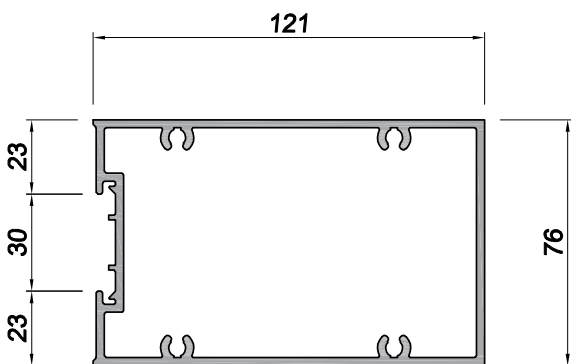

**EX0000090**  
THK. 2.5 mm - 3.155 Kg/m

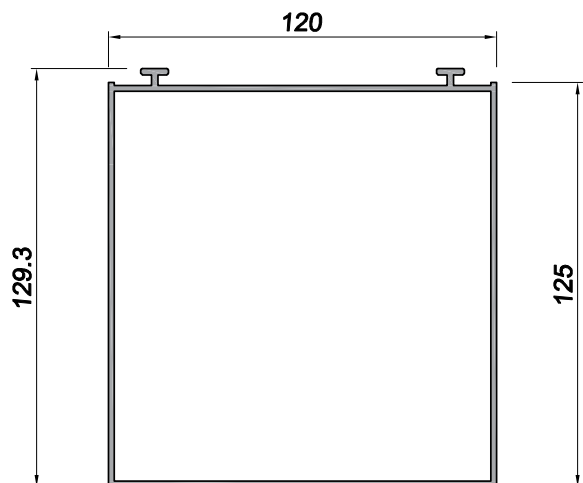

**EX0000098**  
THK. 1.8 mm - 2.483 Kg/m

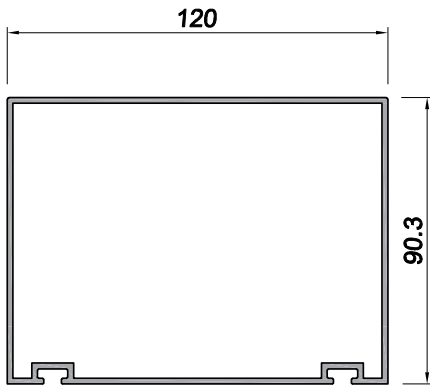

**EX0000100**  
THK. 1.8 mm - 2.149 Kg/m

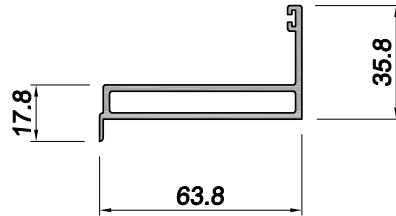

**EX0000096**  
THK. 2.0 mm - 0.945 Kg/m

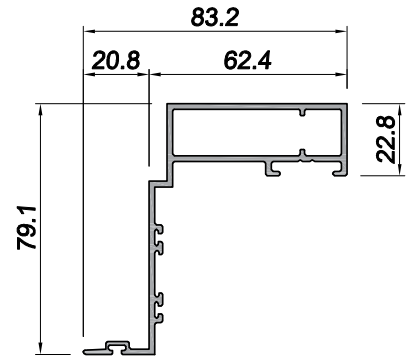

**EX0000097**  
THK. 1.8 mm - 1.270 Kg/m

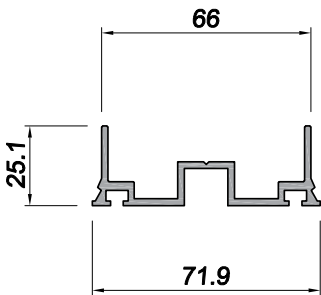

**EX0000093**  
THK. 2.0 mm - 0.907 Kg/m

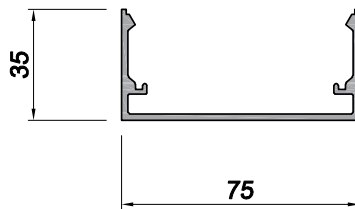

**EX0000099**  
THK. 1.8 mm - 0.898 Kg/m

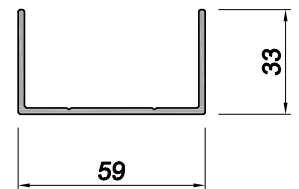

**EX0000101**  
THK. 2.0 mm - 0.653 Kg/m

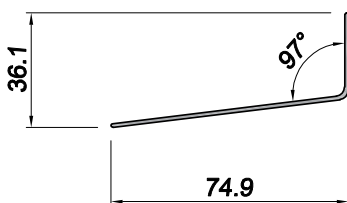

**EX0000102**  
THK. 1.2 mm - 0.328 Kg/m

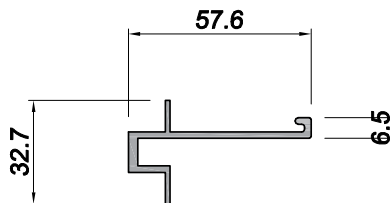

**EX0000095**  
THK. 2.0 mm - 0.577 Kg/m

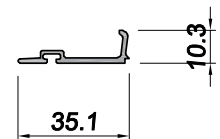

**EX0000094**  
THK. 2.0 mm - 0.200 Kg/m

# MẶT DỰNG CÁCH NHIỆT HỆ 150

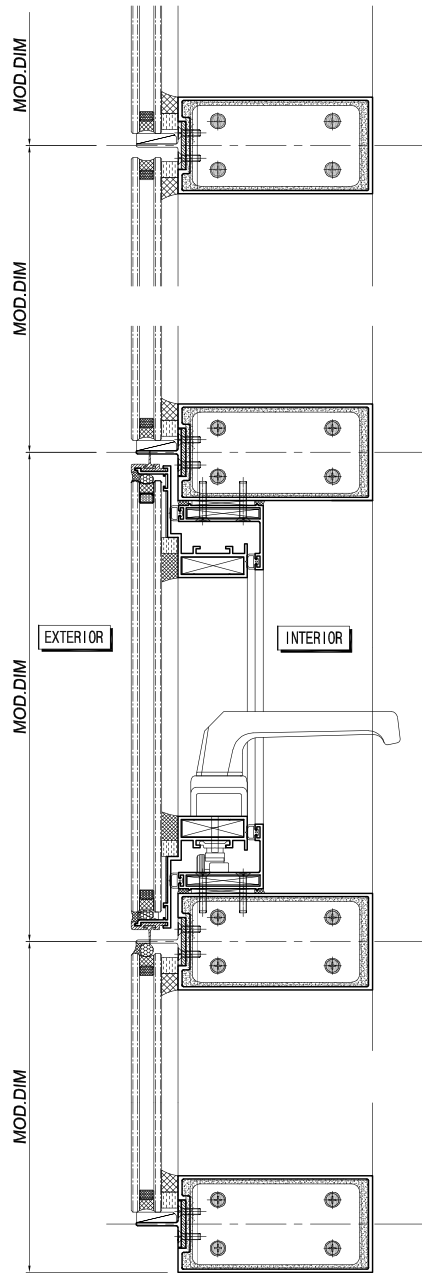

1  
SE-10  
**Vertical Section Detail**  
SCALE : NONE

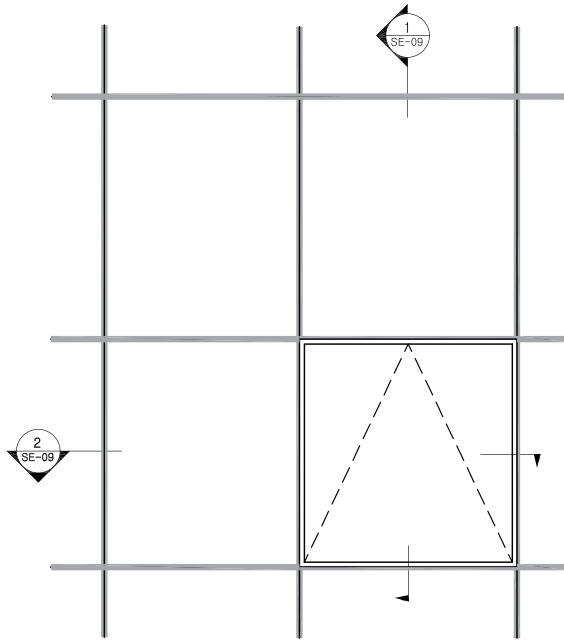

1  
EL-09  
**Project & Fix Elevation**  
SCALE : NONE

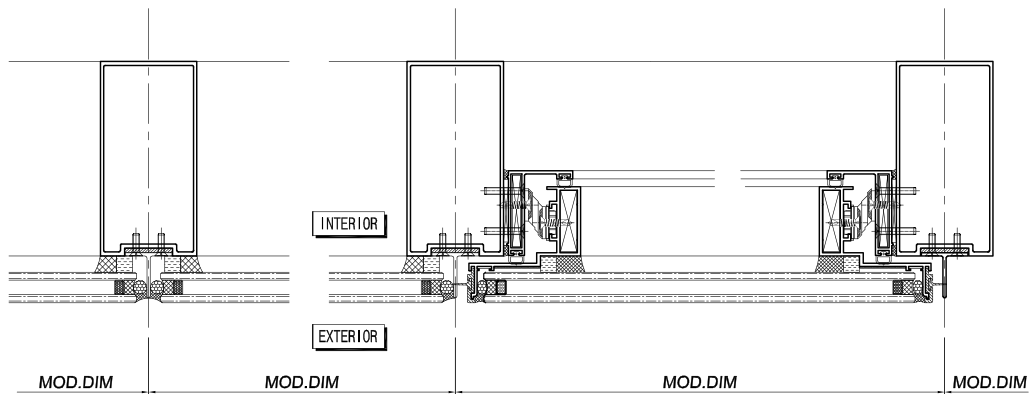

2  
SE-10  
**Horizontal Section Detail**  
SCALE : NONE

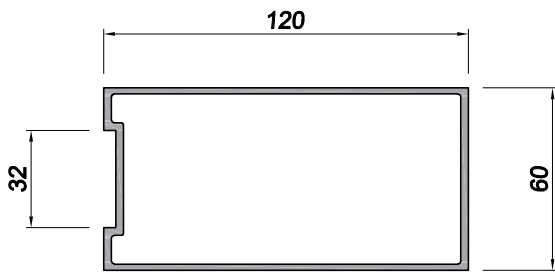

**SBN000001**  
THK. 2.0 mm - 2.117 Kg/m

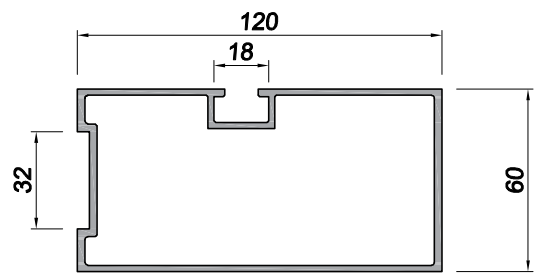

**SBN000002**  
THK. 2.0 mm - 2.284 Kg/m

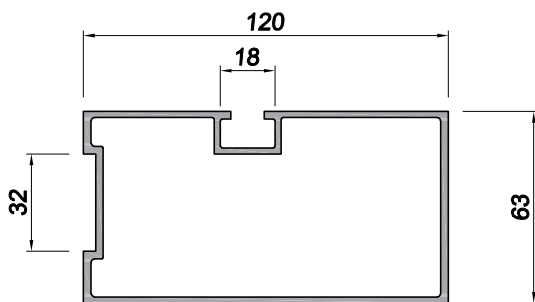

**SBN000015**  
THK. 2.0 mm - 2.336 Kg/m

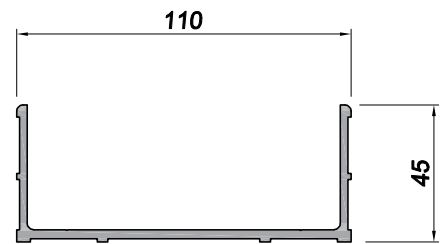

**SBN000006**  
THK. 3.0 mm - 1.525 Kg/m

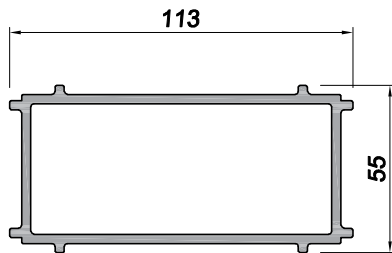

**SBN000007**  
THK. 3.0 mm - 2.641 Kg/m

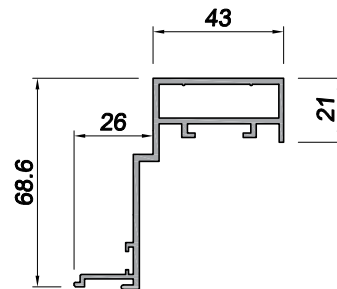

**SBN000003**  
THK. 2.0 mm - 1.112 Kg/m

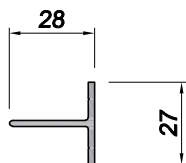

**SBN000004**  
THK. 2.0 mm - 0.287 Kg/m

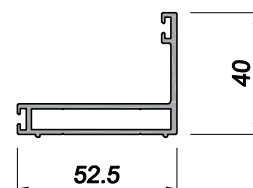

**KNH000011**  
THK. 2.0 mm - 0.736 Kg/m

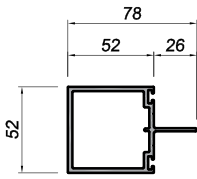

**SRM000003**  
THK. 2.7mm - 1.632 Kg/m

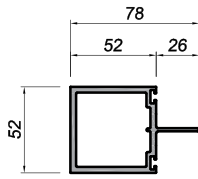

**SRM000009**  
THK. 3.5mm - 1.973 Kg/m

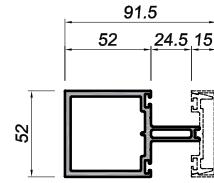

**SRM000008**  
THK. 3.5mm - 2.164 Kg/m

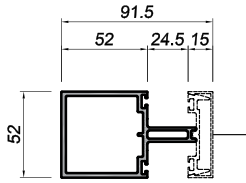

**SRM000002**  
THK. 2.7mm - 1.823 Kg/m

MUL20C004  
MUL20C008

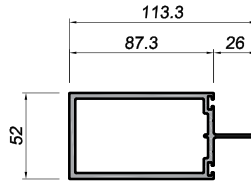

**SRM000012**  
THK. 3.5mm - 2.642 Kg/m

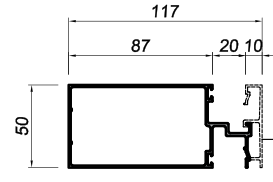

**PANK00002**  
THK. 1.2mm - 1.17 Kg/m

PANK00003

THK. 1.2mm - 0.351 Kg/m

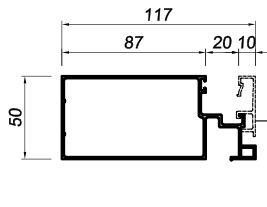

**PANK00004**  
THK. 1.2mm - 1.234 Kg/m

PANK00005

THK. 1.2mm - 0.302 Kg/m

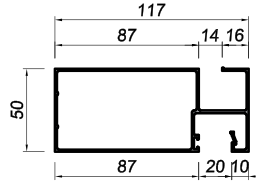

**PANK00006**  
THK. 1.2mm - 1.334 Kg/m

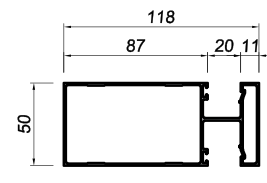

**LAN000001**  
THK. 1.2mm - 1.468 Kg/m

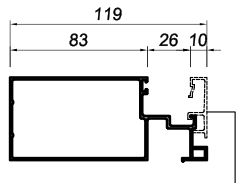

**MYA0000015**  
THK. 1.2mm - 1.234 Kg/m

PANK00005

THK. 1.2mm - 0.302 Kg/m

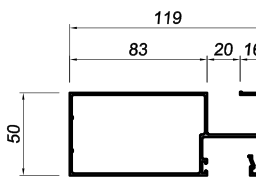

**MYA0000016**  
THK. 1.2mm - 1.334 Kg/m

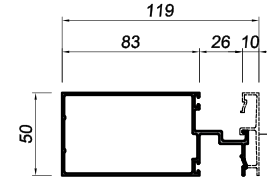

**MYA0000017**  
THK. 1.2mm - 1.169 Kg/m

PANK00003

THK. 1.2mm - 0.351 Kg/m

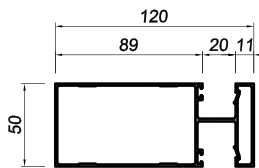

**PANK000001**  
THK. 1.2mm - 1.481 Kg/m

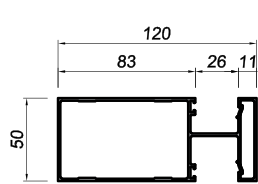

**MYA0000014**  
THK. 1.4mm - 1.603 Kg/m

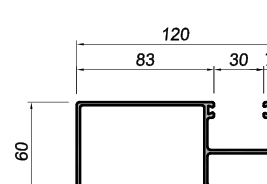

**MUL000823**  
THK. 2.0mm - 2.270 Kg/m

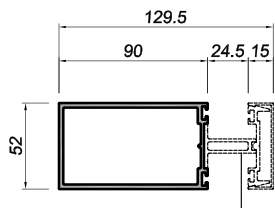

**SRM0000004**  
THK. 2.7mm - 2.005 Kg/m

SRM000005

THK. 1.8mm - 0.476 Kg/m

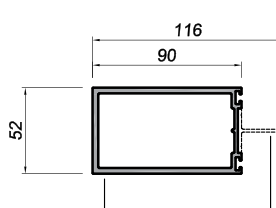

**SRM0000013**  
THK. 3.5 mm - 2.455 Kg/m

SRM000006

THK. 1.8 mm - 0.285 Kg/m

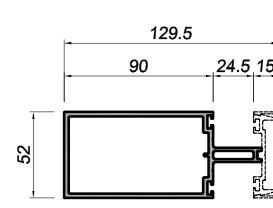

**SRM0000001**  
THK. 2.7mm - 2.380 Kg/m

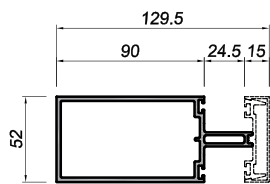

**SRM00007**  
THK. 3.5 mm - 2.885 Kg/m

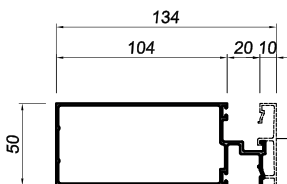

**LAN000006**  
THK. 1.2mm - 1.280 Kg/m

**PANK00003**  
THK. 1.2mm - 0.351 Kg/m

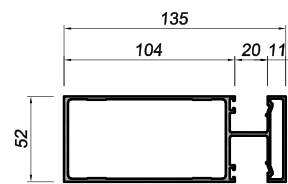

**LAN000005**  
THK. 1.8mm - 2.396 Kg/m

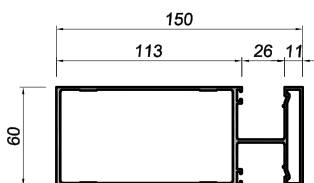

**MYA000001**  
THK. 1.6mm - 2.556 Kg/m

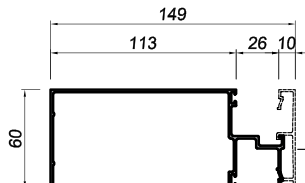

**MYA000002**  
THK. 1.5mm - 1.711 Kg/m

**VNH000005**  
THK. 1.2mm - 0.383 Kg/m

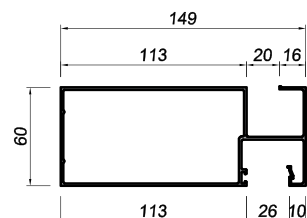

**MYA000003**  
THK. 1.5mm - 1.897 Kg/m

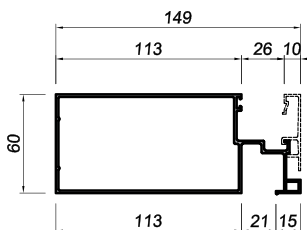

**MYA000004**  
THK. 1.5mm - 1.782 Kg/m

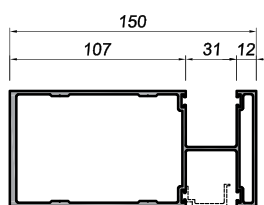

**ATMU02013**  
THK. 2.0mm - 3.400 Kg/m

**ATMU02031**  
THK. 1.5mm - 0.232 Kg/m

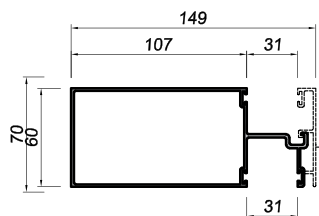

**ATMU02014**  
THK. 1.5mm - 1.835 Kg/m

**ATMU02020**  
THK. 1.5mm - 0.421 Kg/m

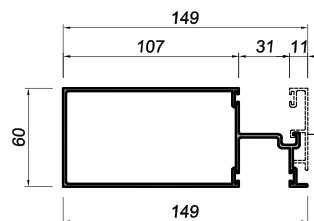

**ATMU02015**  
THK. 1.8mm - 2.068 Kg/m

**ATMU02021**  
THK. 1.5mm - 0.389 Kg/m

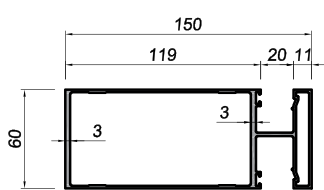

**VNH000001**  
THK. 1.5mm - 2.681 Kg/m

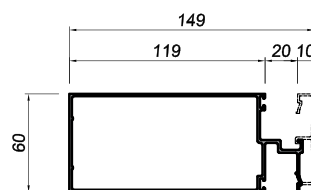

**VNH000002**  
THK. 1.5mm - 1.734 Kg/m

**VNH000005**  
THK. 1.2mm - 0.383 Kg/m

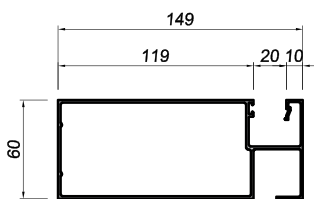

**VNH000003**  
THK. 1.5mm - 1.922 Kg/m

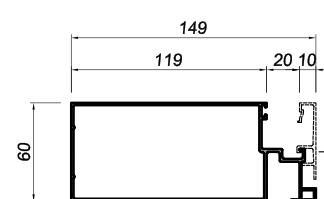

**VNH000004**  
THK. 1.5mm - 1.919 Kg/m

**VNH000006**  
THK. 1.2mm - 0.335 Kg/m

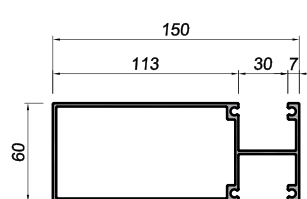

**MUL001372**  
THK. 2.0mm - 2.597 Kg/m

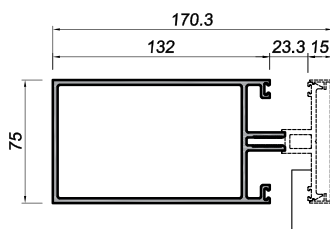

**PLP610302**  
THK. 3.0mm - 3.752 Kg/m

**PLP610118**  
THK. 3.0mm - 1.005 Kg/m

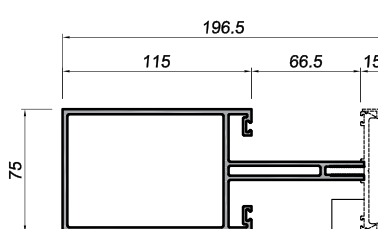

**PLP610300**  
THK. 3.0mm - 4.437 Kg/m

**PLP610218**  
THK. 3.0mm - 0.675 Kg/m

**PLP610119**  
THK. 1.3mm - 0.382 Kg/m



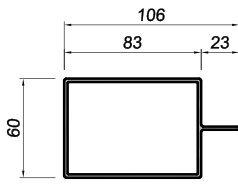

**MUL001135**  
THK. 2.0mm - 1.631 Kg/m

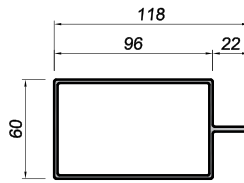

**MUL001111**  
THK. 2.0mm - 1.825 Kg/m

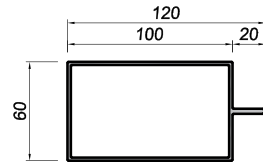

**MUL001438**  
THK. 2.0mm - 1.851 Kg/m

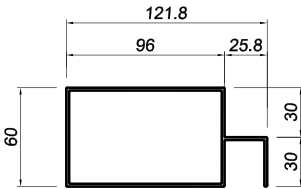

**MUL001434**  
THK. 1.8mm - 1.750 Kg/m

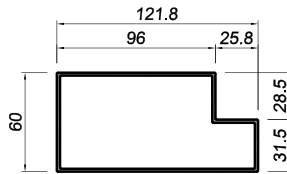

**MUL005708**  
THK. 1.8mm - 1.739 Kg/m

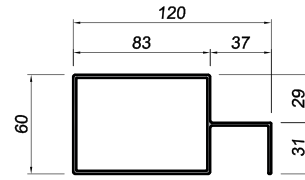

**MUL001396**  
THK. 1.8mm - 1.682 Kg/m

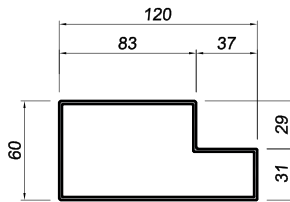

**MUL005393**  
THK. 2.0mm - 1.720 Kg/m

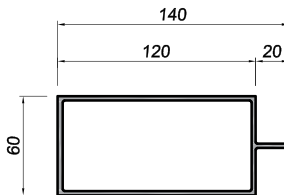

**MYA0000012**  
THK. 2.5 mm - 2.585 Kg/m

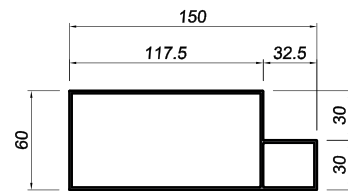

**MUL006594**  
THK. 1.5 mm - 1.793 Kg/m

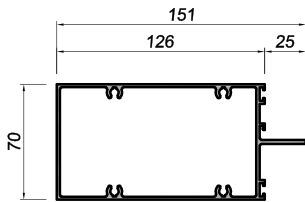

**HAB000117**  
THK. 1.8 mm - 2.56 Kg/m

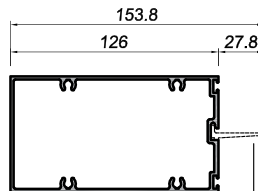

**HAB000105**  
THK. 1.8 mm - 2.461 Kg/m

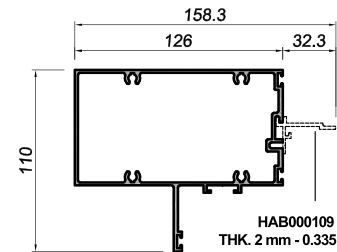

**HAB000108**  
THK. 1.8 mm - 2.879 Kg/m

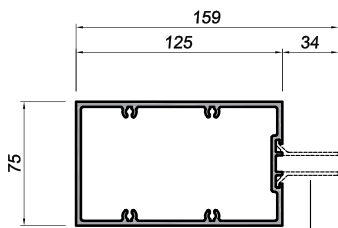

**PLP595300**  
THK. 3 mm - 3.548 Kg/m

**PLP575217**  
THK. 2 mm - 0.265 Kg/m

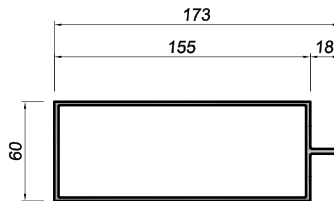

**EX0000475**  
THK. 2.0mm - 2.584 Kg/m

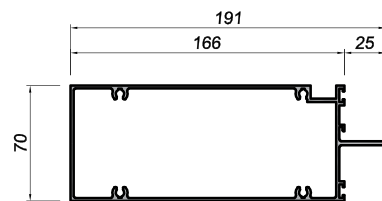

**HAB000115**  
THK. 1.8 mm - 2.968 Kg/m

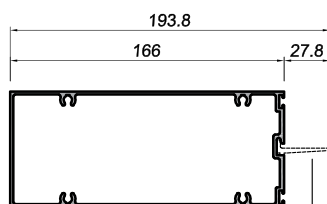

**HAB000106**  
THK. 1.8 mm - 2.851 Kg/m

**HAB000107**  
THK. 2 mm - 0.237 Kg/m

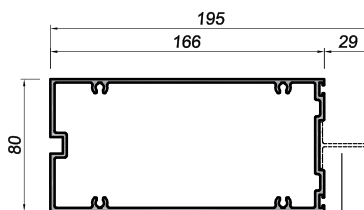

**HAB000023**  
THK. 2 mm - 3.361 Kg/m

**HAB000119**  
THK. 2 mm - 0.299 Kg/m

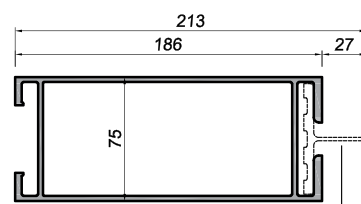

**MUL00U016**  
THK. 3.0 mm - 5.119 Kg/m

**MUL00U018**  
THK. 6.0 mm - 1.110 Kg/m

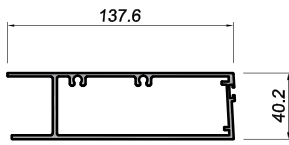

**HAB000018**  
THK. 2.5 mm - 2.334 Kg/m

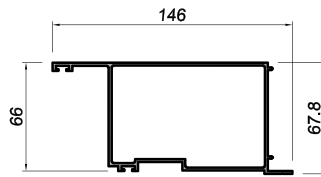

**HAB000210**  
THK. 1.8 mm - 1.99 Kg/m

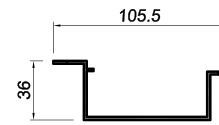

**HAB000211**  
THK. 1.8 mm - 0.833 Kg/m

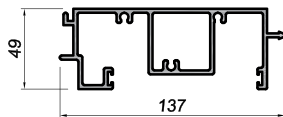

**HAB000120**  
THK. 2.5 mm - 2.905 Kg/m

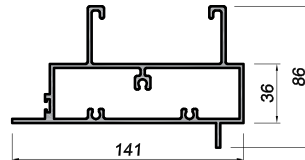

**HAB000123**  
THK. 2.5 mm - 3.323 Kg/m

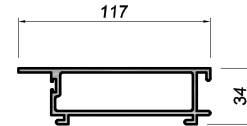

**HAB000121**  
THK. 2.5 mm - 2.005 Kg/m

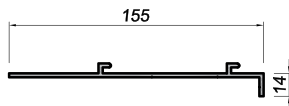

**HAB000122**  
THK. 2.5 mm - 1.274 Kg/m

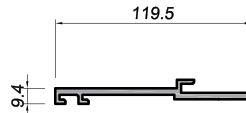

**HAB000004**  
THK. 4 mm - 1.536 Kg/m

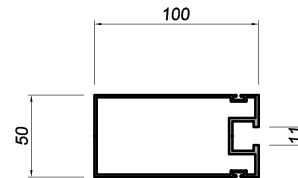

**WSW000002**  
THK. 1.5 mm - 1.532 Kg/m

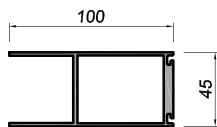

**PLP220615**  
THK. 2 mm - 1.863 Kg/m

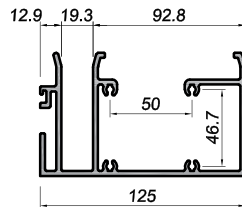

**PLP595304**  
THK. 3 mm - 3.885 Kg/m

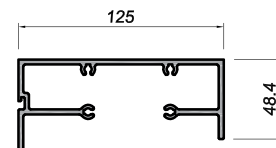

**PLP595303**  
THK. 3 mm - 2.678 Kg/m

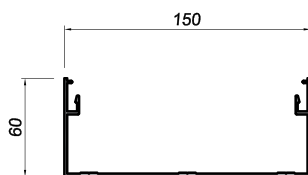

**MP0000007**  
THK. 1.8 mm - 1.589 Kg/m

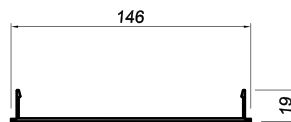

**MP0000008**  
THK. 1.8 mm - 0.831 Kg/m

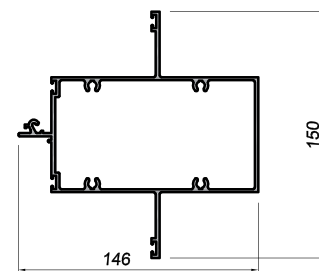

**HAB000110**  
THK. 1.8 mm - 3.216 Kg/m

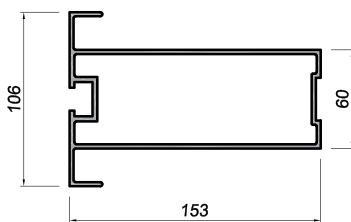

**SKNH00001**  
THK. 2.5 mm - 3.77 Kg/m

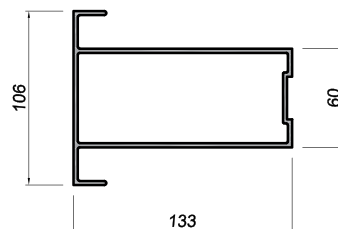

**SKNH00002**  
THK. 2.5 mm - 3.139 Kg/m

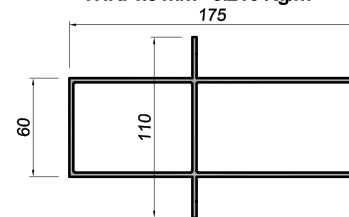

**HAB000035**  
THK. 2.5 mm - 3.832 Kg/m

# PROFILE MẶT DỤNG

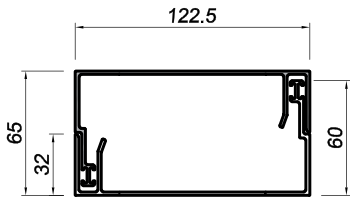

**MUL00U015**  
THK. 1.8mm - 1.260 Kg/m

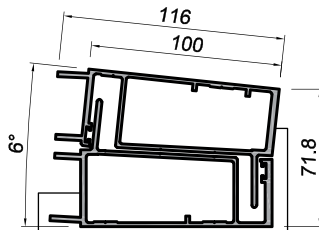

**HAB000017**  
THK. 2.0mm - 2.231 Kg/m

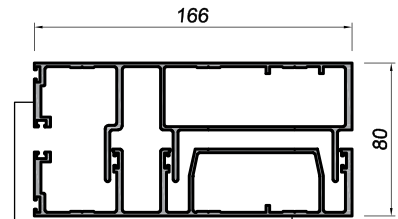

**HAB000001**  
THK. 1.8mm - 3.106 Kg/m

**HAB000016**  
THK. 2.0mm - 2.257 Kg/m

**HAB000002**  
THK. 1.8mm - 2.808 Kg/m

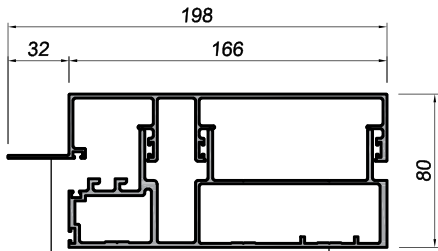

**HAB00002A**  
THK. 2.0mm - 2.045 Kg/m

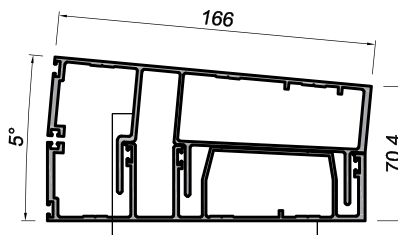

**HAB000019**  
THK. 2.0mm - 3.221 Kg/m

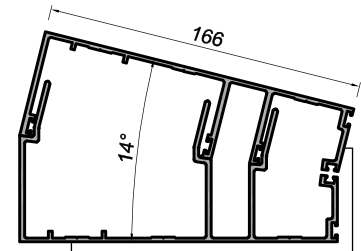

**HAB000024**  
THK. 2.0mm - 2.935 Kg/m

**HAB000003**  
THK. 2.0mm - 3.532 Kg/m

**HAB000020**  
THK. 2.0mm - 2.936 Kg/m

**HAB000025**  
THK. 2.0mm - 2.362 Kg/m

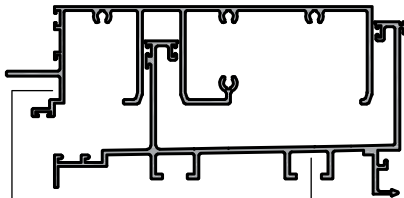

**HAB000111**  
THK. 2.5 mm - 3.276 Kg/m

**HAB000112**  
THK. 2 mm - 3.114 Kg/m

**HAB000010**  
THK. 2.5 mm - 1.347 Kg/m

**HAB000008**  
THK. 2.5 mm - 3.627 Kg/m

**HAB000003**  
THK. 2.0 mm - 3.532 Kg/m

**HAB000009**  
THK. 2.5 mm - 3.69 Kg/m

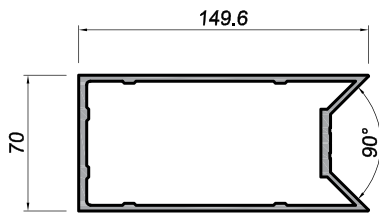

**HDPK00001**  
THK. 3 mm - 4.026 Kg/m

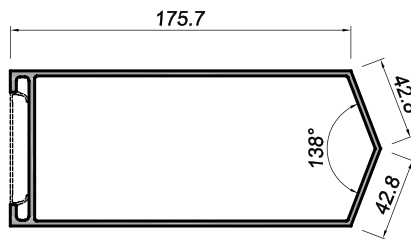

**PKNH00028**  
THK. 2.5 mm - 3.707 Kg/m

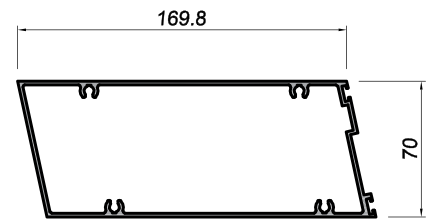

**HAB000118**  
THK. 1.8 mm - 2.834 Kg/m

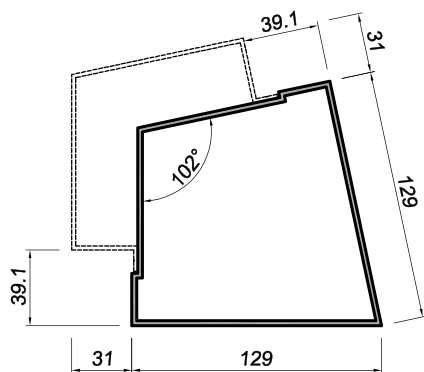

**PKNH00014**  
THK. 2 mm - 1.438 Kg/m

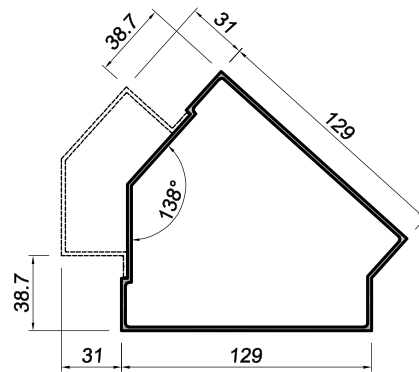

**PKNH00015**  
THK. 2.5 mm - 3.103 Kg/m

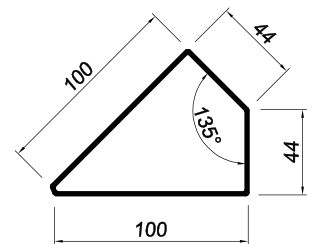

**ACN000076**  
THK. 1.2 mm - 0.937 Kg/m

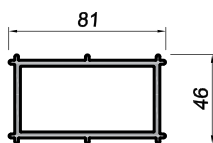

**SRM000011**  
THK. 3 mm - 1.924 Kg/m

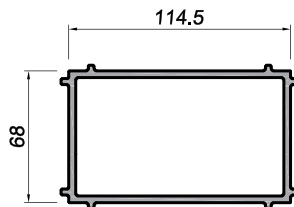

**PKNH00009**  
THK. 2 mm - 1.003 Kg/m

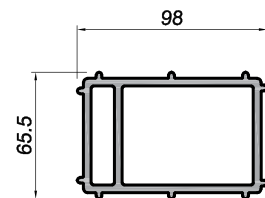

**PKNH00008**  
THK. 2 mm - 2.512 Kg/m

**ATMU02038**  
THK. 4 mm - 3.879 Kg/m

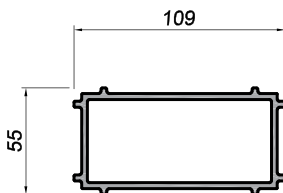

**VNH000009**  
THK. 3 mm - 2.578 Kg/m

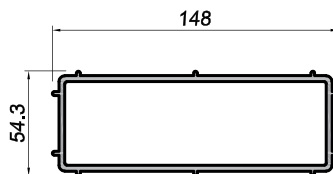

**EX0000477**  
THK. 3.0 mm - 3.124 Kg/m

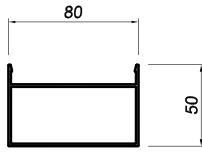

**SRM000020**  
THK. 1.5 mm - 1.039 Kg/m

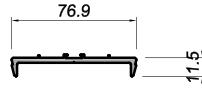

**SRM000021**  
THK. 3 mm - 0.758 Kg/m

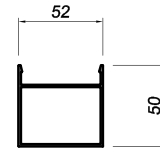

**SRM000022**  
THK. 1.5 mm - 0.812 Kg/m

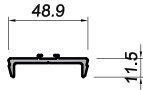

**SRM000023**  
THK. 3 mm - 0.522 Kg/m

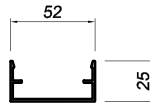

**SRM000024**  
THK. 1.5 mm - 0.454 Kg/m

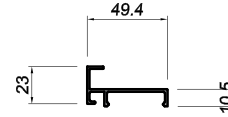

**SRM000025**  
THK. 1.5 mm - 0.422 Kg/m

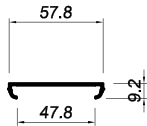

**PKNH00034**  
THK. 1.2 mm - 0.243 Kg/m

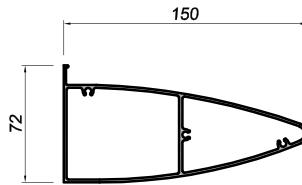

**MP0000006**  
THK. 1.8 mm - 2.233 Kg/m

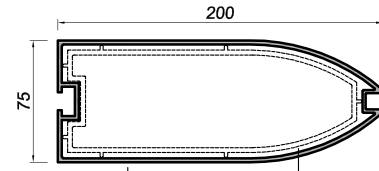

**HAB0000033**  
THK. 2.5 mm - 3.635 Kg/m

**HAB0000034**  
THK. 3 mm - 3.81 Kg/m

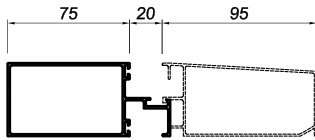

**MUL20C013**  
THK. 1.3mm - 1.091 Kg/m

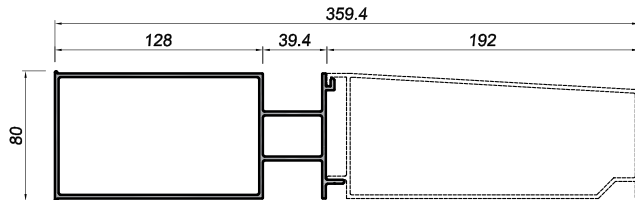

**MUL20C014**  
THK. 1.3mm - 1.033 Kg/m

**PKNH00011**  
THK. 2.3 mm - 6.095 Kg/m

**PKNH00012**  
THK. 2.3 mm - 3.294 Kg/m

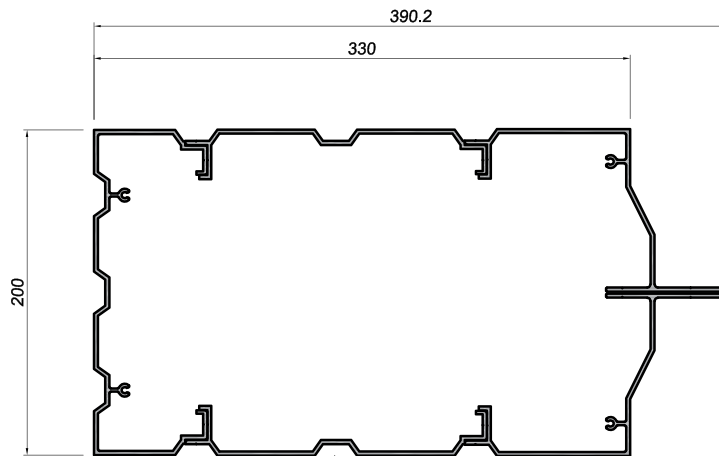

**HAB0000007**  
THK. 2.5 mm - 2.978 Kg/m

**HAB0000006**  
THK. 2.5 mm - 1.674 Kg/m

**HAB0000005**  
THK. 2.5 mm - 2.183 Kg/m

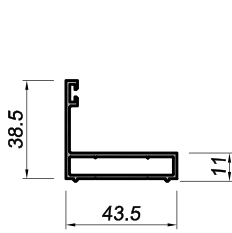

**MYA000005**  
THK. 1.4 mm - 0.54 Kg/m

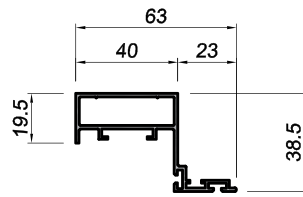

**MYA000006**  
THK. 1.4 mm - 0.695 Kg/m

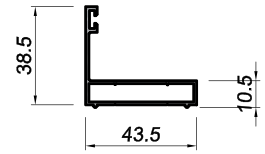

**PANK00007**  
THK. 1.2 mm - 0.476 Kg/m

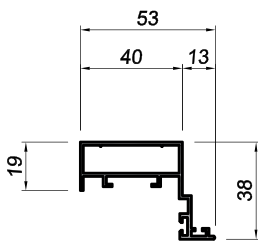

**PANK00008**  
THK. 1.2 mm - 0.574 Kg/m

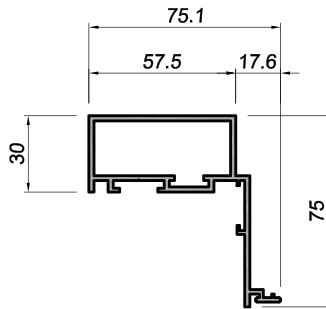

**HAB000202**  
THK. 2.0 mm - 1.399 Kg/m

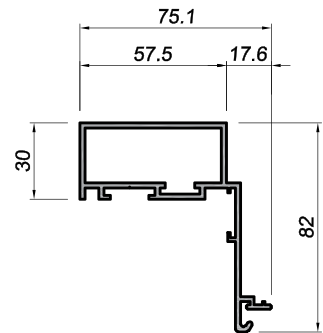

**HAB000203**  
THK. 2.0 mm - 1.467 Kg/m

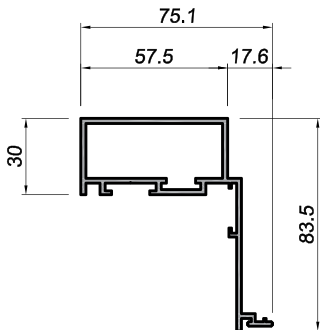

**HAB000212**  
THK. 2.0 mm - 1.444 Kg/m

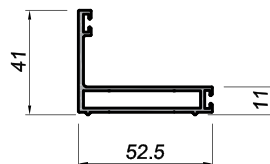

**KNH000011**  
THK. 1.6 mm - 0.736 Kg/m

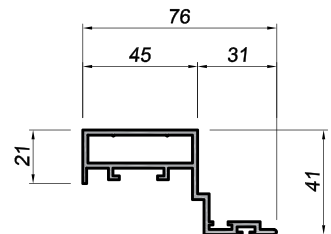

**PKNH0007B**  
THK. 2.0 mm - 1.062 Kg/m

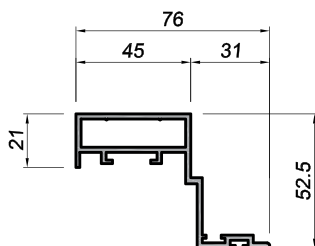

**PKNH00007**  
THK. 2.0 mm - 1.124 Kg/m

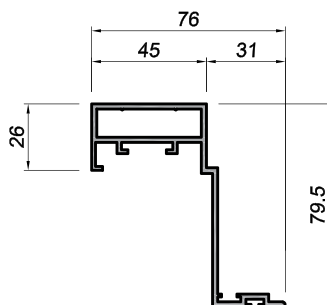

**PKNH00006**  
THK. 2.0 mm - 1.302 Kg/m

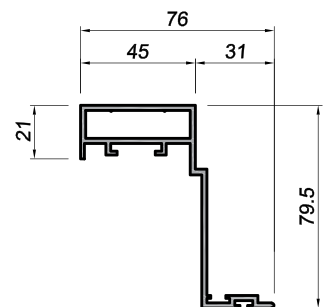

**PKNH00005**  
THK. 2.0 mm - 1.271 Kg/m

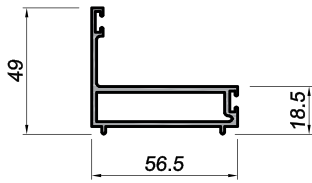

**ATPJ08089**  
THK. 2.0 mm - 1.008 Kg/m

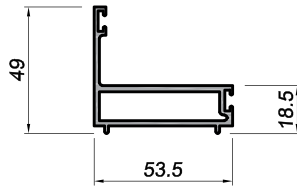

**ATPJ08094**  
THK. 2.0 mm - 0.973 Kg/m

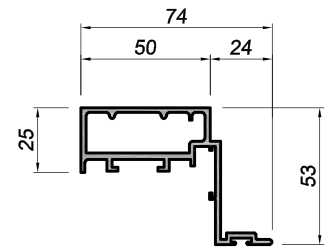

**ATPJ08090**  
THK. 2.0 mm - 1.264 Kg/m

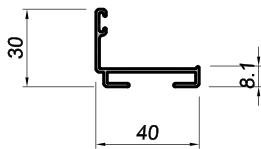

**MUL000824**  
THK. 1.35 mm - 0.358 Kg/m

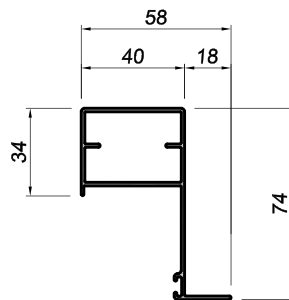

**MUL000825**  
THK. 1.35 mm - 0.795 Kg/m

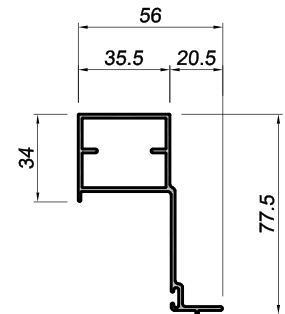

**MUL001110**  
THK. 1.5 mm - 0.860 Kg/m

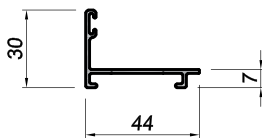

**MUL001182**  
THK. 1.5mm - 0.363 Kg/m

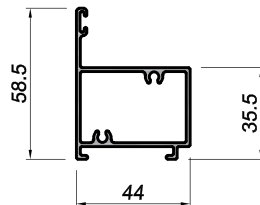

**MUL001181**  
THK. 1.5mm - 0.849 Kg/m

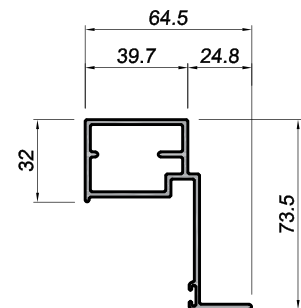

**MUL001180**  
THK. 2.0 mm - 1.202 Kg/m

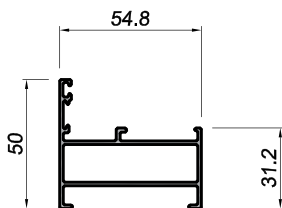

**HDPK00005**  
THK. 1.4 mm - 0.805 Kg/m

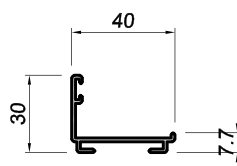

**EX0000479**  
THK. 1.5 mm - 0.375 Kg/m

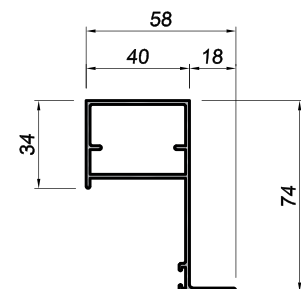

**EX0000478**  
THK. 1.5 mm - 0.876 Kg/m



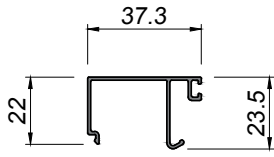

**HDPK00002**  
THK. 1 mm - 0.272 Kg/m

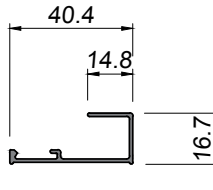

**090FX1029**  
THK. 1.1mm - 0.241 Kg/m

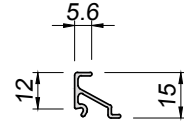

**090FX1049**  
THK. 1.1mm - 0.124Kg/m

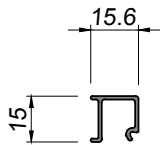

**090FX1039**  
THK. 1.1mm - 0.145 Kg/m

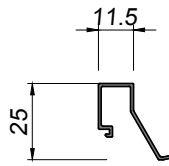

**080GB0001**  
THK. 0.95 mm - 0.164 Kg/m

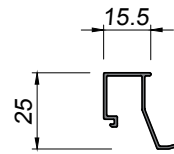

**080GB0002**  
THK. 0.95 mm - 0.176 Kg/m

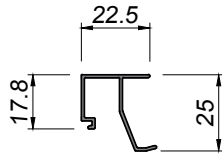

**080GB0003**  
THK. 1.0 mm - 0.203 Kg/m

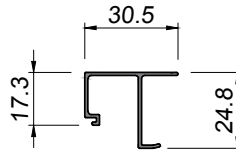

**080GB0004**  
THK. 1.0 mm - 0.224 Kg/m

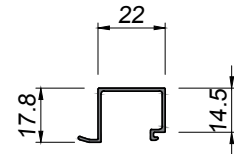

**050GB0001**  
THK. 0.95 mm - 0.173 Kg/m

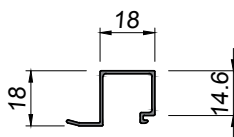

**050GB0002**  
THK. 0.95 mm - 0.175 Kg/m

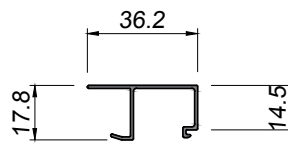

**050GB0003**  
THK. 0.95 mm - 0.210Kg/m

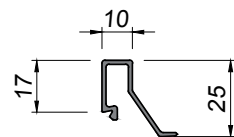

**120GB0001**  
THK. 1.3 mm - 0.229 Kg/m

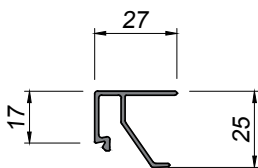

**120GB0002**  
THK. 1.3 mm - 0.289 Kg/m

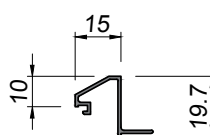

**NAH-0005**  
THK. 1 mm - 0.156 Kg/m

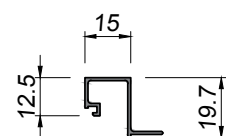

**NAH-0006**  
THK. 1 mm - 0.169 Kg/m

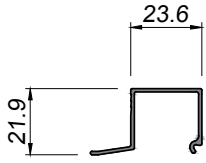

**038PJ1009**  
THK. 1.1 mm - 0.241 Kg/m

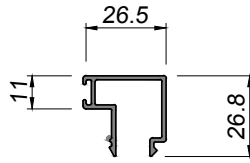

**065DR3119**  
THK. 1.35mm - 0.344 Kg/m

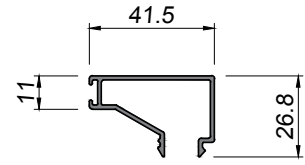

**065DR1719**  
THK. 1.35mm - 0.422 Kg/m

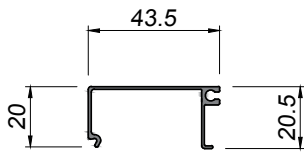

**100FX1019**  
THK. 1.2mm - 0.252 Kg/m

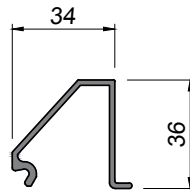

**100FX1029**  
THK. 1.2mm - 0.504 Kg/m

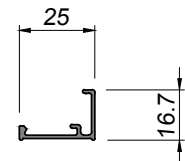

**025GB0001**  
THK. 1.0 mm - 0.164 Kg/m

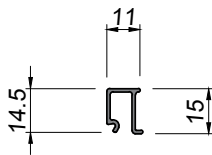

**MP0000003**  
THK. 1.1 mm - 0.131 Kg/m

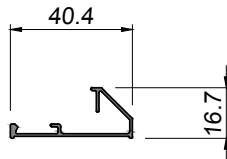

**040GB0001**  
THK. 0.9 mm - 0.205 Kg/m

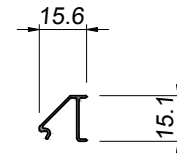

**040GB0001**  
THK. 0.7 mm - 0.084 Kg/m

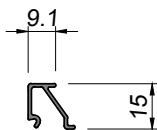

**042GB0001**  
THK. 1.1 mm - 0.131 Kg/m

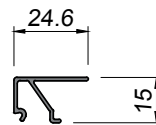

**042GB0002**  
THK. 1.1 mm - 0.178 Kg/m

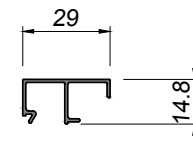

**052GB1001**  
THK. 1.0 mm - 0.188 Kg/m

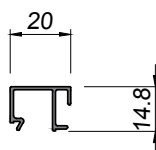

**052GB2001**  
THK. 1.0 mm - 0.164 Kg/m

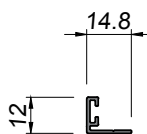

**015GB0001**  
THK. 1.0 mm - 0.095 Kg/m

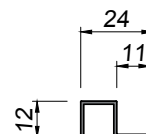

**024GB0001**  
THK. 1.0 mm - 0.154 Kg/m

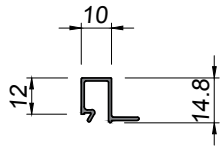

**052GB3001**  
THK. 1.0 mm - 0.137 Kg/m

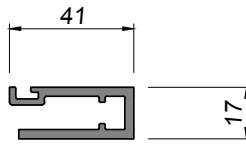

**PLP610186**  
THK. 3.0 mm - 0.775 Kg/m

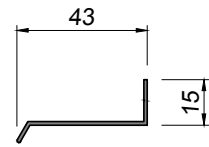

**MUL006703**  
THK. 1.2 mm - 0.195 Kg/m

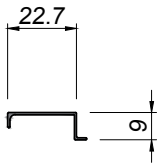

**SLC000126**  
THK. 0.7 mm - 0.075 Kg/m

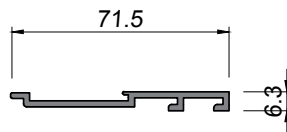

**HAB000015**  
THK. 2 mm - 0.5 Kg/m

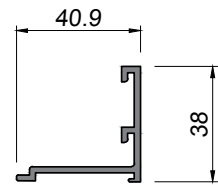

**HAB000104**  
THK. 2 mm - 0.511 Kg/m

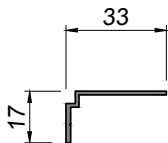

**HAB000213**  
THK. 1.2 mm - 0.168 Kg/m

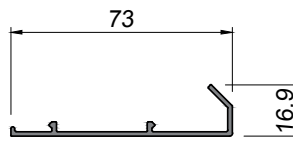

**SRM000017**  
THK. 1.5 mm - 0.405 Kg/m

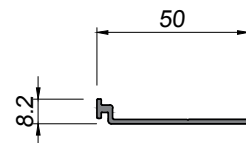

**SRM000018**  
THK. 1.5 mm - 0.245 Kg/m

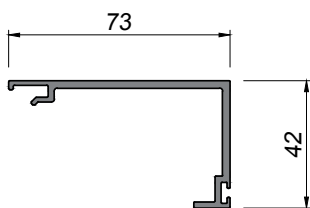

**SRM000019**  
THK. 2.5 mm - 0.844 Kg/m

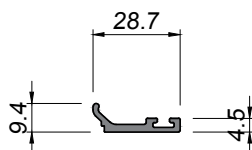

**PLP220209**  
THK. 2.5 mm - 0.229 Kg/m

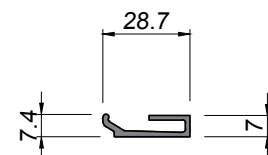

**PLP220219**  
THK. 1.5 mm - 0.231 Kg/m

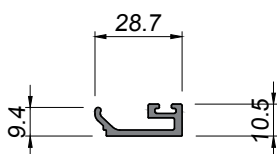

**PLP220609**  
THK. 2.0 mm - 0.302 Kg/m

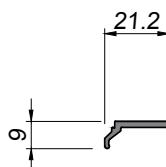

**PLP575117**  
THK. 2.0 mm - 0.135 Kg/m

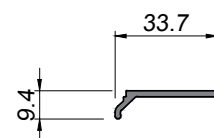

**PLP595208**  
THK. 2.0 mm - 0.210 Kg/m

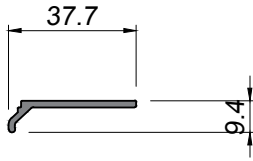

**PLP570209**  
THK. 2 mm - 0.232 Kg/m

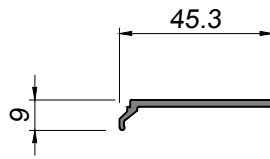

**PLP575217**  
THK. 2 mm - 0.265 Kg/m

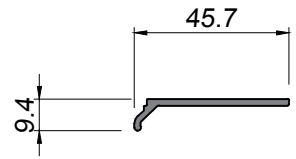

**PLP575218**  
THK. 2 mm - 0.275 Kg/m

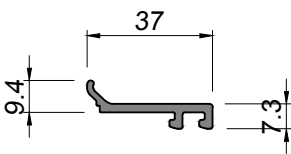

**PLP595324**  
THK. 2.5 mm - 0.348 Kg/m

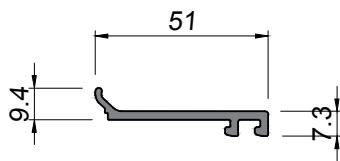

**PLP595224**  
THK. 2.5 mm - 0.443 Kg/m

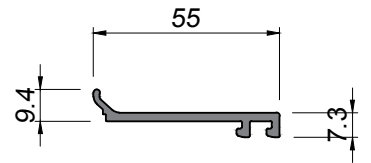

**PLP595225**  
THK. 2.5 mm - 0.47 Kg/m

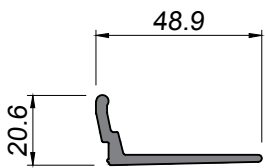

**PLP575118**  
THK. 3.2 mm - 0.484 Kg/m

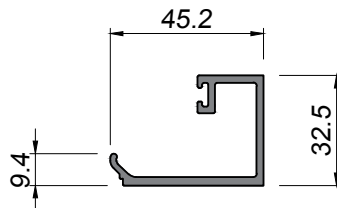

**PLP595307**  
THK. 2.0 mm - 0.671 Kg/m

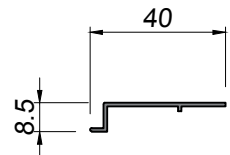

**MYA000007**  
THK. 1.0 mm - 0.132 Kg/m

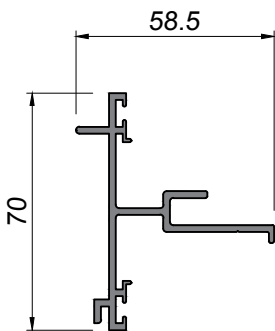

**HAB000116**  
THK. 2.0 mm - 0.970 Kg/m

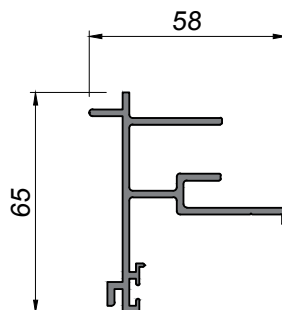

**HAB000113**  
THK. 2.0 mm - 1.039 Kg/m

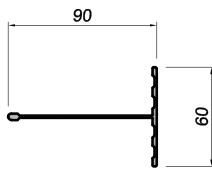

**060TB0090**  
THK. 1.4mm - 0.709 Kg/m

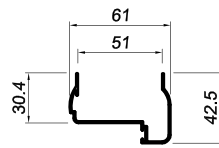

**JEIL00004**  
THK. 1.0 mm - 0.415 Kg/m

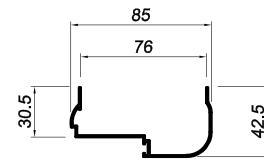

**JEIL00005**  
THK. 1.0 mm - 0.465 Kg/m

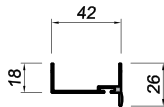

**JEIL00006**  
THK. 1.1 mm - 0.284 Kg/m

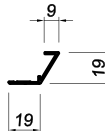

**JEIL00007**  
THK. 1.0 mm - 0.145 Kg/m

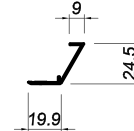

**JEIL00008**  
THK. 1.0 mm - 0.163 Kg/m

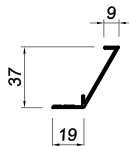

**JEIL00009**  
THK. 1.1 mm - 0.221 Kg/m

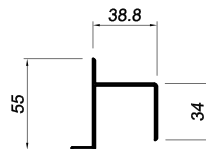

**JEIL00010**  
THK. 1.2 mm - 0.456 Kg/m

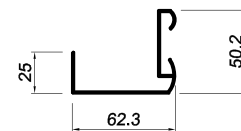

**JEIL00011**  
THK. 1.0 mm - 0.464 Kg/m

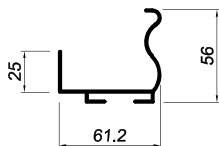

**JEIL00012**  
THK. 1.0 mm - 0.476 Kg/m

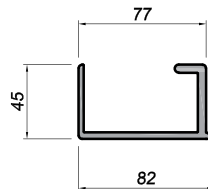

**JEIL00013**  
THK. 5.0 mm - 1.937 Kg/m

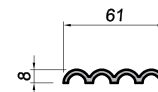

**JEIL00014**  
THK. 2.5 mm - 0.561 Kg/m

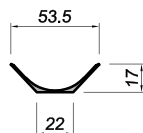

**JEIL00015**  
THK. 1.1 mm - 0.264 Kg/m

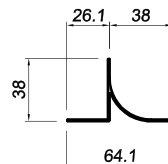

**JEIL00016**  
THK. 1.0 mm - 0.311 Kg/m

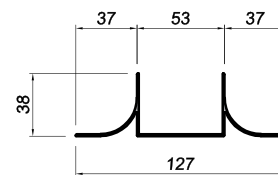

**JEIL00017**  
THK. 1.1 mm - 0.651 Kg/m

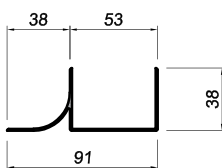

**JEIL00018**  
THK. 1.2 mm - 0.563 Kg/m



**038AG0075**  
THK. 1.2 mm - 0.363 Kg/m

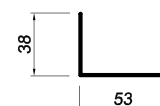

**038CN0053**  
THK. 1.1 mm - 0.377 Kg/m

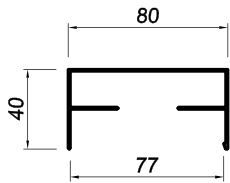

**084FX0001**  
THK. 1.0 mm - 0.562 Kg/m

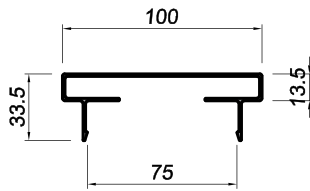

**EX0000175**  
THK. 1.2 mm - 0.724 Kg/m

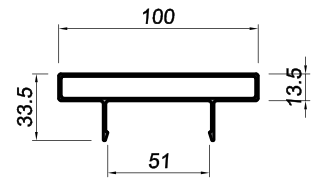

**EX0000140A**  
THK. 1.2 mm - 0.864 Kg/m

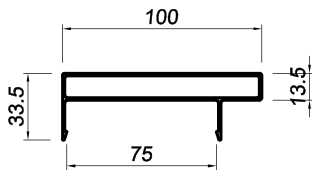

**EX0000492**  
THK. 1.2 mm - 0.864 Kg/m

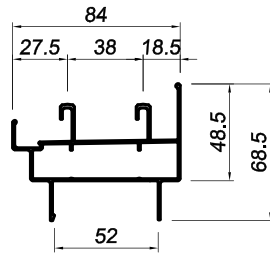

**084FS121A**  
THK. 1.0 mm - 1.016 Kg/m

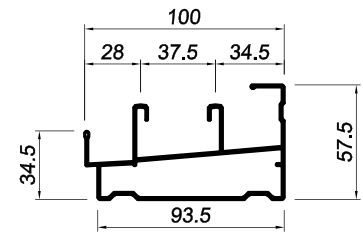

**EX0000146**  
THK. 1.0 mm - 1.107 Kg/m

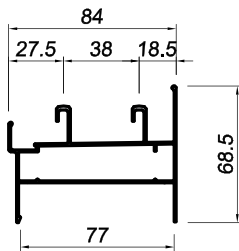

**084FS111A**  
THK. 1.0 mm - 1.022 Kg/m

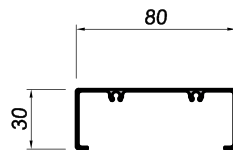

**080CN0030**  
THK. 1.0 mm - 0.490 Kg/m

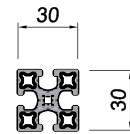

**MSZ009414**  
THK. 1.3 mm - 0.912 Kg/m

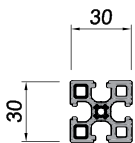

**EX0000472**  
THK. 1.8 mm - 0.886 Kg/m

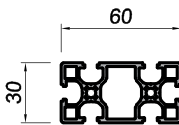

**EX0000471**  
THK. 1.8 mm - 1.419 Kg/m

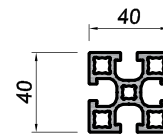

**MSZ009416**  
THK. 2.4 mm - 1.746 Kg/m

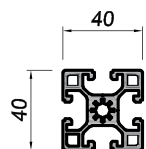

**EX0000457**  
THK. 2.0 mm - 1.662 Kg/m

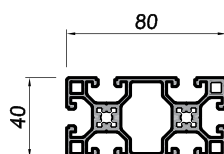

**EX0000458**  
THK. 2.0 mm - 2.590 Kg/m

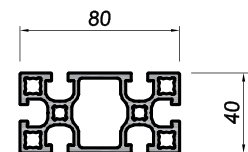

**MSZ009413**  
THK. 2.0 mm - 2.846 Kg/m

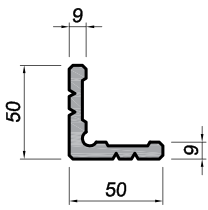

**EX0000214**  
THK. 7.0mm - 1.845 Kg/m

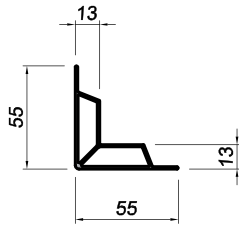

**055CP0013**  
THK. 1.2mm - 0.695 Kg/m

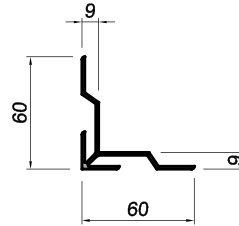

**060CP0009**  
THK. 1.5mm - 0.641 Kg/m

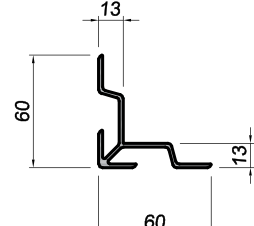

**060CP0013**  
THK. 2.0mm - 0.882 Kg/m

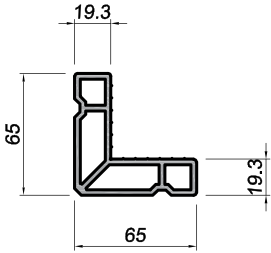

**065CP0020**  
THK. 3.0mm - 2.363 Kg/m

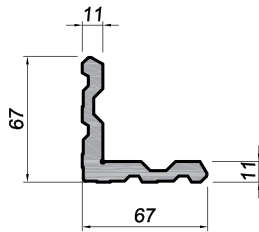

**ATMU02035**  
THK. 7.8mm - 2.857 Kg/m

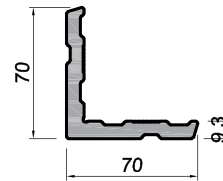

**070CP0009**  
THK. 9.3 mm - 2.873 Kg/m

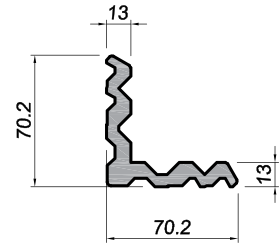

**ATMU02036**  
THK. 8.5mm - 3.068 Kg/m

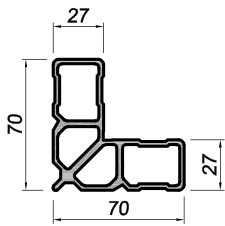

**MUL0003002**  
THK. 3.0 mm - 2.540 Kg/m

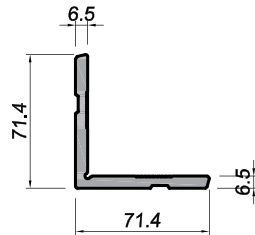

**035P19115**  
THK. 6.5mm - 2.263 Kg/m

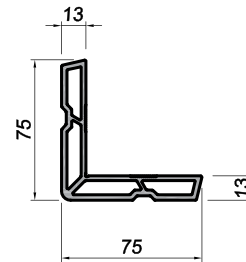

**075CP0013**  
THK. 3.0mm - 2.283 Kg/m

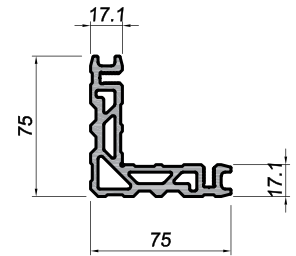

**075CP0017**  
THK. 1.8mm - 3.40 Kg/m

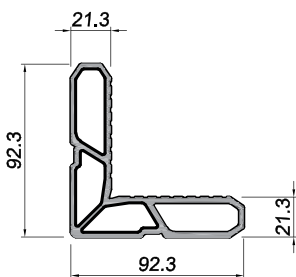

**HAB000204**  
THK. 2.5mm - 3.048 Kg/m

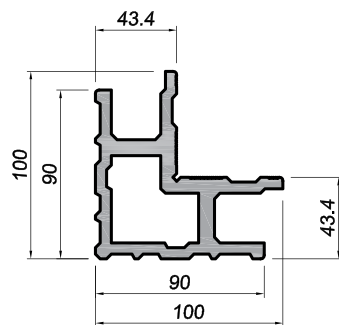

**100CP0011**  
THK. 6.0mm - 6.744 Kg/m

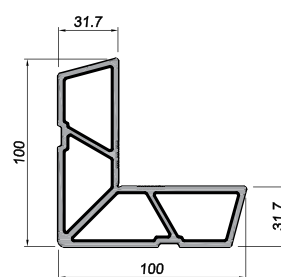

**100CP0031**  
THK. 3.0 mm - 3.900 Kg/m

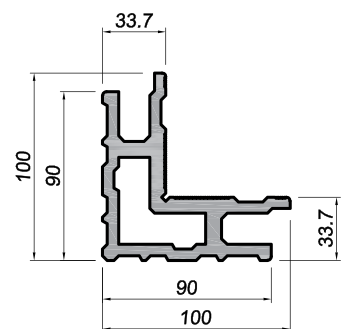

**100CP0033**  
THK. 6.0mm - 6.728 Kg/m



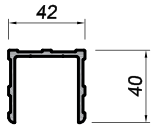

**SRM000010**  
THK. 2.5mm - 0.878 Kg/m

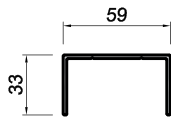

**EX0000101**  
THK. 2.0mm - 0.653 Kg/m

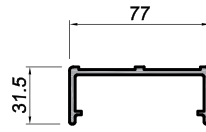

**HAB000408**  
THK. 3.0mm - 1.159 Kg/m

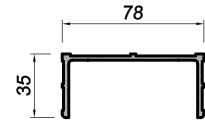

**DCV000006**  
THK. 2.5mm - 1.043 Kg/m

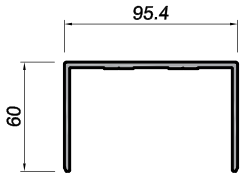

**MUL20H005**  
THK. 3.0mm - 1.739 Kg/m

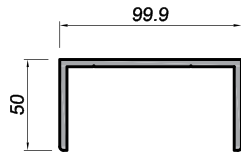

**ATMU02039**  
THK. 4.0mm - 2.074 Kg/m

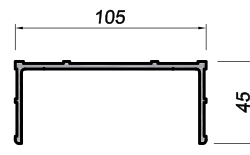

**MYA0000013**  
THK. 3.0mm - 1.485 Kg/m

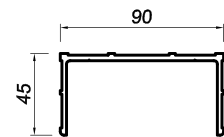

**THT000003**  
THK. 3.0mm - 1.363 Kg/m

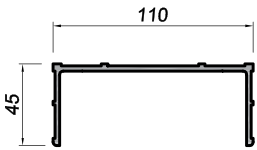

**VNH000008**  
THK. 3.0mm - 1.525 Kg/m

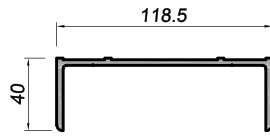

**PKNH00004**  
THK. 3.0mm - 1.678 Kg/m

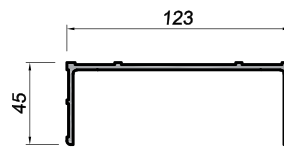

**DCV000012**  
THK. 3.0mm - 1.631 Kg/m

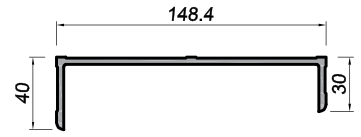

**EX0000476**  
THK. 3.5mm - 2.031 Kg/m

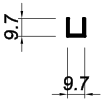

**010CN0010**  
THK. 0.7mm - 0.053 Kg/m



**070CN0012**  
THK. 0.7mm - 0.056 Kg/m

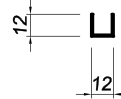

**012CN0012**  
THK. 0.7mm - 0.066 Kg/m

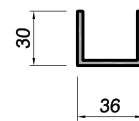

**CHA0001069**  
THK. 3.0mm - 0.731 Kg/m

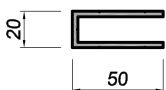

**CHA0001060**  
THK. 3.0mm - 0.926 Kg/m

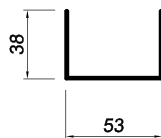

**038CN0053**  
THK. 1.1mm - 0.377 Kg/m

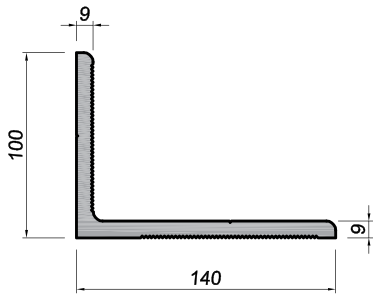

**SBN000008**  
THK. 9.0 mm - 5.379 Kg/m

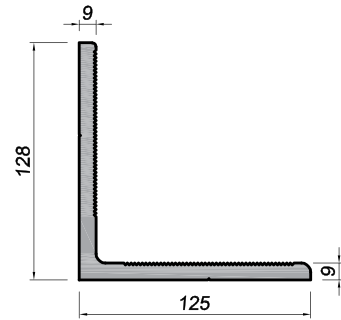

**SBN000009**  
THK. 9.0 mm - 5.700 Kg/m

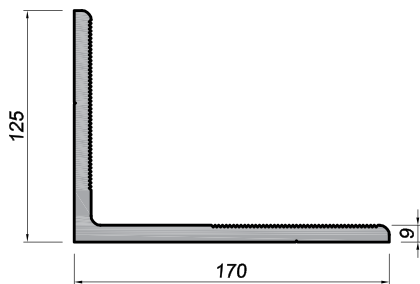

**SBN000010**  
THK. 9.0 mm - 6.712 Kg/m

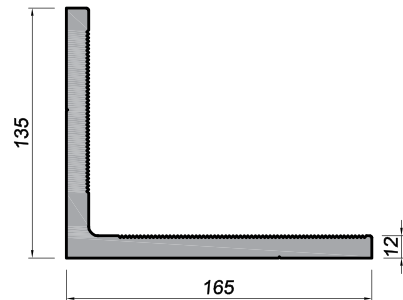

**SBN000011**  
THK. 12 mm - 9.076 Kg/m

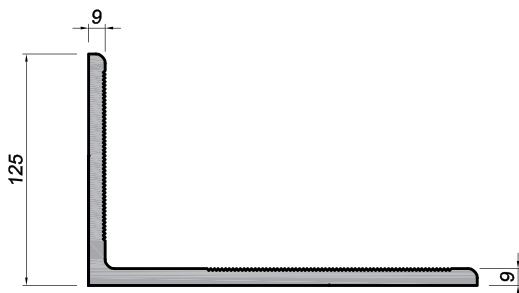

**SBN000014**  
THK. 9.0 mm - 7.633 Kg/m

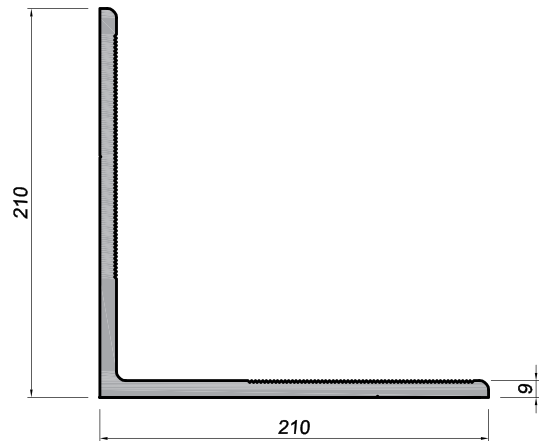

**SBN000012**  
THK. 9.0 mm - 9.664 Kg/m

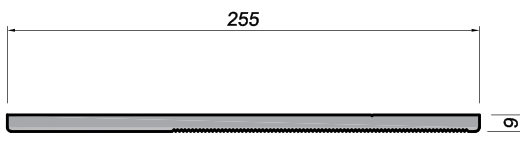

**SBN000013**  
THK. 9.0 mm - 5.997 Kg/m

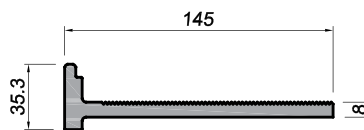

**PKNH00035**  
THK. 8.0 mm - 3.611 Kg/m

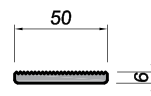

**PKNH0035A**  
THK. 6.0 mm - 0.743 Kg/m

# VÁCH NGĂN VÀ NAN CHỖ

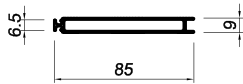

**085SP0001**  
THK. 1.0mm - 0.478 Kg/m

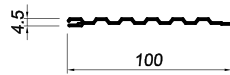

**100SP0001**  
THK. 1.0mm - 0.237 Kg/m

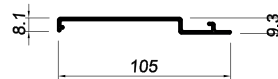

**105SP0001**  
THK. 1.2mm - 0.420 Kg/m

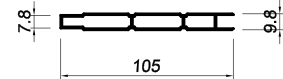

**105SP0002**  
THK. 0.7mm - 0.457 Kg/m

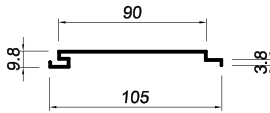

**105SP0003**  
THK. 0.7mm - 0.259 Kg/m

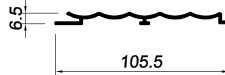

**105SP0004**  
THK. 0.7mm - 0.253 Kg/m



**124SP0001**  
THK. 1.0mm - 0.758 Kg/m

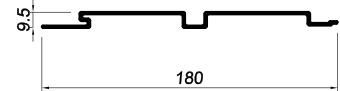

**180SP0001**  
THK. 1.2mm - 0.723 Kg/m

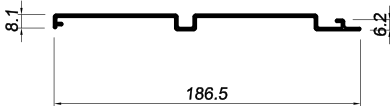

**186SP0001**  
THK. 1.2mm - 0.747 Kg/m



**SPA001332**  
THK. 1.1mm - 0.868 Kg/m

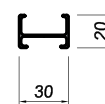

**030GA0001**  
THK. 1.2mm - 0.262 Kg/m

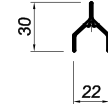

**030GA0002**  
THK. 0.9mm - 0.19 Kg/m

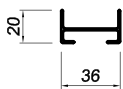

**036GA0001**  
THK. 1.1mm - 0.262 Kg/m

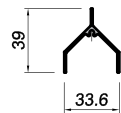

**036GA0002**  
THK. 1.2mm - 0.298 Kg/m

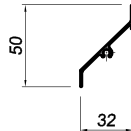

**036GA0003**  
THK. 1.0mm - 0.232 Kg/m

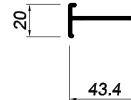

**043GA0001**  
THK. 1.1mm - 0.260 Kg/m

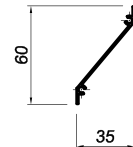

**043GA0002**  
THK. 1.0mm - 0.238 Kg/m

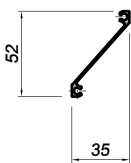

**043GA0003**  
THK. 1.1mm - 0.292 Kg/m

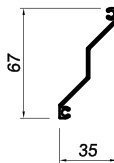

**GA000136**  
THK. 1.2mm - 0.358 Kg/m

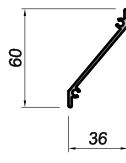

**VNH000007**  
THK. 2.0mm - 0.440 Kg/m

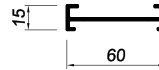

**060GA0001**  
THK. 1.0mm - 0.283 Kg/m

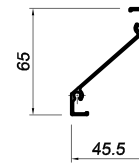

**060GA0002**  
THK. 1.0mm - 0.366 Kg/m

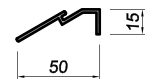

**HAB000209**  
THK. 2 mm - 0.405 Kg/m

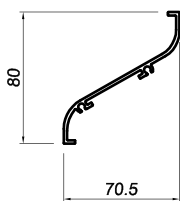

**MUL0009368**  
THK. 2.0mm - 0.822 Kg/m

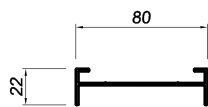

**PKNH00036**  
THK. 1.5mm - 0.544 Kg/m

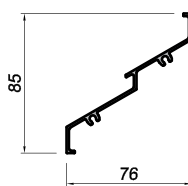

**KNH000029**  
THK. 1.5mm - 0.704 Kg/m

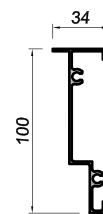

**HAB000207**  
THK. 1.5 mm - 0.837 Kg/m

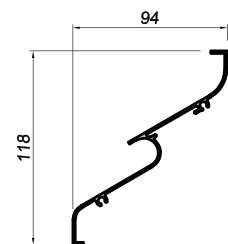

**HAB000208**  
THK. 1.5 mm - 0.934 Kg/m

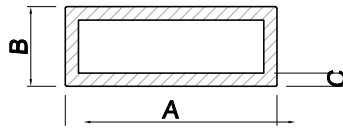

| No | DIES No    | A    | B    | C   | U-Weight (Kg/m) |
|----|------------|------|------|-----|-----------------|
| 1  | 008PS0009  | 8.5  | 9    | 0.7 | 0.061           |
| 2  | 010PS0010  | 10   | 10   | 0.7 | 0.071           |
| 3  | 012PS0012  | 12   | 12   | 1.0 | 0.119           |
| 4  | 015PS0010  | 15   | 10   | 0.7 | 0.090           |
| 5  | 020PS0010  | 20   | 10   | 1.1 | 0.166           |
| 6  | 020PS0012  | 20   | 12   | 0.7 | 0.116           |
| 7  | 025PS0009  | 25   | 9    | 1.0 | 0.173           |
| 8  | 025PS0012  | 25   | 12   | 0.7 | 0.135           |
| 9  | 025PS0025  | 25   | 25   | 1.0 | 0.260           |
| 10 | PIP001252  | 25   | 25   | 1.1 | 0.285           |
| 11 | 030PS0020  | 30   | 20   | 1.1 | 0.285           |
| 12 | 030PS0030  | 30   | 30   | 1.2 | 0.375           |
| 13 | 035PS0035  | 35   | 35   | 1.0 | 0.369           |
| 14 | 038PS0025  | 38   | 25   | 0.7 | 0.234           |
| 15 | EX0000172  | 38   | 25   | 1.8 | 0.580           |
| 16 | 038PS0038  | 38   | 38   | 1.0 | 0.401           |
| 17 | 040PS0020  | 40   | 20   | 0.7 | 0.222           |
| 18 | 040PS020A  | 40   | 20   | 1.0 | 0.314           |
| 19 | 042PS0042  | 42.3 | 42.3 | 1.0 | 0.448           |
| 20 | 045PS0045  | 45   | 45   | 1.0 | 0.477           |
| 21 | 045PS045A  | 45   | 45   | 1.5 | 0.705           |
| 22 | 045PS0065  | 45   | 65   | 2.0 | 1.151           |
| 23 | 050PS0025  | 50   | 25   | 0.9 | 0.357           |
| 24 | PIP0008135 | 50   | 26   | 2.6 | 0.994           |
| 25 | 076PS0025  | 76   | 25   | 1.0 | 0.537           |
| 26 | 076PS025A  | 76   | 25   | 1.1 | 0.589           |
| 27 | 076PS038   | 76   | 38   | 1.0 | 0.607           |
| 28 | 076PS0045  | 76   | 44.5 | 1.0 | 0.642           |
| 29 | 076PS0052  | 76   | 52   | 1.8 | 1.184           |
| 30 | 076PS0076  | 76   | 76   | 1.1 | 0.893           |
| 31 | 080PS0030  | 80   | 30   | 1.0 | 0.585           |
| 32 | 080PS1030  | 80   | 30   | 1.2 | 0.793           |
| 33 | 080PS0035  | 80   | 35   | 1.0 | 0.612           |
| 34 | 080PS0080  | 80   | 80   | 1.1 | 0.939           |
| 35 | 080PS080A  | 80   | 80   | 1.6 | 1.358           |
| 36 | 085PS0040  | 83.5 | 40   | 1.0 | 0.658           |

| No | DIES No    | A   | B   | C    | U-Weight (Kg/m) |
|----|------------|-----|-----|------|-----------------|
| 37 | PIP0008187 | 90  | 30  | 3.5  | 2.203           |
| 38 | 100PS0025  | 100 | 25  | 1.2  | 0.797           |
| 39 | 100PS0030  | 100 | 30  | 1.0  | 0.694           |
| 40 | PIP0008121 | 100 | 45  | 1.0  | 0.775           |
| 41 | 100PS0045  | 100 | 45  | 1.1  | 0.852           |
| 42 | 100PS1045  | 100 | 45  | 1.1  | 0.948           |
| 43 | EX0000139  | 100 | 45  | 1.5  | 1.154           |
| 44 | EX0000147  | 100 | 45  | 1.8  | 1.379           |
| 45 | EX0000428  | 100 | 45  | 3.0  | 2.260           |
| 46 | 100PS0100  | 100 | 100 | 1.2  | 1.283           |
| 47 | 100PS0110  | 100 | 110 | 1.2  | 1.348           |
| 48 | 120PS0045  | 120 | 45  | 1.2  | 1.058           |
| 49 | 120PS045A  | 120 | 45  | 1.5  | 1.317           |
| 50 | SE0000002  | 120 | 60  | 1.5  | 1.441           |
| 51 | EX0000966  | 150 | 30  | 2.1  | 2.079           |
| 52 | EX0000844  | 150 | 50  | 1.5  | 1.602           |
| 53 | PKNH00037  | 150 | 60  | 3.0  | 3.317           |
| 54 | PIP0015080 | 150 | 80  | 13.0 | 14.337          |
| 55 | EX0000912  | 160 | 80  | 2.5  | 3.184           |
| 56 | EX0000956  | 170 | 45  | 1.8  | 2.152           |
| 57 | PIP0008188 | 190 | 50  | 2.0  | 2.684           |

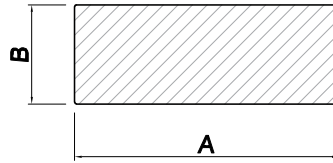

| No | DIES No   | A  | B  | U-Weight (Kg/m) |
|----|-----------|----|----|-----------------|
| 1  | BAR001632 | 5  | 5  | 0.071           |
| 2  | BAR001633 | 6  | 6  | 0.102           |
| 3  | BAR001634 | 8  | 8  | 0.179           |
| 4  | BAR001635 | 10 | 10 | 0.276           |
| 5  | BAR001636 | 12 | 12 | 0.399           |
| 6  | BAR001637 | 15 | 3  | 0.127           |
| 7  | BAR001638 | 15 | 5  | 0.209           |
| 8  | BAR001639 | 15 | 6  | 0.249           |
| 9  | BAR001640 | 15 | 8  | 0.331           |
| 10 | BAR001641 | 15 | 10 | 0.412           |
| 11 | BAR001642 | 15 | 12 | 0.493           |
| 12 | BAR001643 | 15 | 15 | 0.621           |
| 13 | BAR001644 | 16 | 16 | 0.706           |
| 14 | BAR001645 | 20 | 3  | 0.170           |
| 15 | BAR001646 | 20 | 4  | 0.224           |
| 16 | BAR001647 | 20 | 5  | 0.279           |
| 17 | BAR001648 | 20 | 6  | 0.333           |
| 18 | BAR001649 | 20 | 8  | 0.441           |
| 19 | BAR001650 | 20 | 10 | 0.550           |
| 20 | BAR001651 | 20 | 12 | 0.658           |
| 21 | BAR001652 | 20 | 15 | 0.821           |
| 22 | BAR001653 | 20 | 16 | 0.875           |
| 23 | BAR001654 | 20 | 20 | 1.100           |
| 24 | BAR001655 | 25 | 3  | 0.213           |
| 25 | BAR001656 | 25 | 5  | 0.348           |
| 26 | BAR001657 | 25 | 8  | 0.552           |
| 27 | BAR001658 | 25 | 10 | 0.687           |
| 28 | BAR001659 | 25 | 12 | 0.823           |
| 29 | BAR001660 | 25 | 15 | 1.026           |
| 30 | BAR001661 | 25 | 16 | 1.094           |
| 31 | BAR001744 | 25 | 20 | 1.365           |
| 32 | BAR001745 | 25 | 25 | 1.727           |
| 33 | BAR001662 | 30 | 8  | 0.662           |
| 34 | BAR001663 | 30 | 10 | 0.825           |
| 35 | BAR001664 | 30 | 12 | 0.987           |
| 36 | BAR001665 | 30 | 15 | 1.231           |

| No | DIES No   | A  | B  | U-Weight (Kg/m) |
|----|-----------|----|----|-----------------|
| 37 | BAR001666 | 30 | 16 | 1.312           |
| 38 | BAR001667 | 30 | 20 | 1.638           |
| 39 | BAR001668 | 30 | 25 | 2.052           |
| 40 | BAR001669 | 30 | 30 | 2.479           |
| 41 | BAR001746 | 30 | 3  | 0.256           |
| 42 | BAR001747 | 30 | 4  | 0.337           |
| 43 | BAR001748 | 30 | 5  | 0.418           |
| 44 | BAR001749 | 30 | 6  | 0.499           |
| 45 | BAR001670 | 32 | 32 | 2.818           |
| 46 | BAR001671 | 35 | 10 | 0.962           |
| 47 | BAR001672 | 35 | 12 | 1.152           |
| 48 | BAR001673 | 35 | 20 | 1.911           |
| 49 | BAR001674 | 35 | 25 | 2.394           |
| 50 | BAR001675 | 35 | 30 | 2.869           |
| 51 | BAR001676 | 35 | 35 | 3.367           |
| 52 | BAR001677 | 38 | 38 | 3.964           |
| 53 | BAR001678 | 39 | 22 | 2.531           |
| 54 | BAR001679 | 40 | 3  | 0.341           |
| 55 | BAR001680 | 40 | 4  | 0.449           |
| 56 | BAR001681 | 40 | 5  | 0.558           |
| 57 | BAR001682 | 40 | 6  | 0.666           |
| 58 | BAR001683 | 40 | 8  | 0.883           |
| 59 | BAR001684 | 40 | 10 | 1.100           |
| 60 | BAR001685 | 40 | 12 | 1.316           |
| 61 | BAR001686 | 40 | 15 | 1.642           |
| 62 | BAR001687 | 40 | 16 | 1.750           |
| 63 | BAR001688 | 40 | 20 | 2.184           |
| 64 | BAR001689 | 40 | 25 | 2.737           |
| 65 | BAR001690 | 40 | 30 | 3.279           |
| 66 | BAR001691 | 40 | 35 | 3.821           |
| 67 | BAR001772 | 40 | 40 | 4.390           |
| 68 | BAR001773 | 42 | 31 | 3.556           |
| 69 | BAR001692 | 45 | 30 | 3.688           |
| 70 | BAR001693 | 45 | 35 | 4.298           |
| 71 | BAR001694 | 45 | 40 | 4.908           |
| 72 | BAR001774 | 45 | 8  | 0.993           |

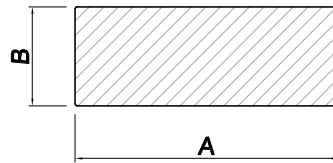

| No  | DIES No   | A  | B    | U-Weight (Kg/m) |
|-----|-----------|----|------|-----------------|
| 73  | BAR001775 | 45 | 12   | 1.481           |
| 74  | BAR001776 | 45 | 15   | 1.478           |
| 75  | BAR001777 | 45 | 20   | 2.439           |
| 76  | BAR001285 | 50 | 3    | 0.433           |
| 77  | BAR001697 | 50 | 4    | 0.562           |
| 78  | BAR001698 | 50 | 5    | 0.697           |
| 79  | BAR001699 | 50 | 6    | 0.833           |
| 80  | BAR001700 | 50 | 8    | 1.104           |
| 81  | BAR001701 | 50 | 10   | 1.375           |
| 82  | BAR001702 | 50 | 12   | 1.646           |
| 83  | BAR001703 | 50 | 15   | 2.052           |
| 84  | BAR001704 | 50 | 16   | 2.188           |
| 85  | BAR001705 | 50 | 17   | 2.323           |
| 86  | BAR001706 | 50 | 18   | 2.459           |
| 87  | BAR001707 | 50 | 20   | 2.730           |
| 88  | BAR001708 | 50 | 25   | 3.421           |
| 89  | BAR001709 | 50 | 30   | 4.098           |
| 90  | BAR001710 | 50 | 35   | 4.776           |
| 91  | BAR001550 | 55 | 33   | 5.253           |
| 92  | BAR001547 | 55 | 10   | 1.512           |
| 93  | BAR001548 | 55 | 15   | 2.258           |
| 94  | BAR001549 | 55 | 30   | 4.508           |
| 95  | BAR001551 | 55 | 40   | 5.999           |
| 96  | BAR001714 | 55 | 13   | 1.959           |
| 97  | BAR001715 | 55 | 25   | 3.763           |
| 98  | BAR001126 | 60 | 15   | 2.438           |
| 99  | BAR001717 | 60 | 16   | 2.625           |
| 100 | BAR001718 | 60 | 20   | 3.276           |
| 101 | BAR001719 | 60 | 25   | 4.105           |
| 102 | BAR001720 | 60 | 27.5 | 4.512           |
| 103 | BAR001721 | 60 | 30   | 4.918           |
| 104 | BAR001802 | 60 | 4    | 0.674           |
| 105 | BAR001803 | 60 | 5    | 0.837           |
| 106 | BAR001804 | 60 | 6    | 0.999           |
| 107 | BAR001805 | 60 | 8    | 1.325           |
| 108 | BAR001806 | 60 | 10   | 1.650           |

| No  | DIES No   | A  | B  | U-Weight (Kg/m) |
|-----|-----------|----|----|-----------------|
| 109 | BAR001807 | 60 | 12 | 1.975           |
| 110 | BAR001555 | 65 | 12 | 2.140           |
| 111 | BAR001556 | 65 | 15 | 2.686           |
| 112 | BAR001557 | 65 | 16 | 2.844           |
| 113 | BAR001558 | 65 | 20 | 3.522           |
| 114 | BAR001559 | 65 | 25 | 4.447           |
| 115 | BAR001560 | 65 | 30 | 5.328           |
| 116 | BAR001561 | 65 | 35 | 6.209           |
| 117 | BAR001562 | 65 | 40 | 7.089           |
| 118 | BAR001728 | 65 | 10 | 1.787           |
| 119 | BAR001729 | 65 | 18 | 3.197           |
| 120 | BAR002003 | 65 | 20 | 3.549           |
| 121 | BAR001516 | 70 | 5  | 0.948           |
| 122 | BAR001734 | 70 | 5  | 0.948           |
| 123 | BAR001735 | 70 | 6  | 1.166           |
| 124 | BAR001736 | 70 | 8  | 1.545           |
| 125 | BAR001737 | 70 | 10 | 1.925           |
| 126 | BAR001738 | 70 | 12 | 2.304           |
| 127 | BAR001739 | 70 | 15 | 2.873           |
| 128 | BAR001740 | 70 | 16 | 3.063           |
| 129 | BAR001741 | 70 | 18 | 3.442           |
| 130 | BAR001742 | 70 | 20 | 3.822           |
| 131 | BAR001743 | 70 | 22 | 4.220           |
| 132 | BAR001832 | 70 | 25 | 4.789           |
| 133 | BAR001754 | 71 | 4  | 0.798           |
| 134 | BAR001566 | 75 | 10 | 2.062           |
| 135 | BAR001567 | 75 | 12 | 2.469           |
| 136 | BAR001568 | 75 | 15 | 3.079           |
| 137 | BAR001569 | 75 | 16 | 3.282           |
| 138 | BAR001570 | 75 | 20 | 4.095           |
| 139 | BAR001571 | 75 | 25 | 5.131           |
| 140 | BAR001572 | 75 | 30 | 6.148           |
| 141 | BAR001573 | 75 | 35 | 7.164           |
| 142 | BAR001574 | 75 | 40 | 8.180           |
| 143 | BAR001759 | 80 | 5  | 1.116           |
| 144 | BAR001760 | 80 | 6  | 1.333           |

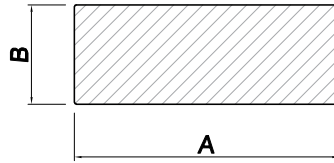

| No  | DIES No   | A   | B    | U-Weight (Kg/m) |
|-----|-----------|-----|------|-----------------|
| 145 | BAR001761 | 80  | 8    | 1.766           |
| 146 | BAR001762 | 80  | 10   | 2.200           |
| 147 | BAR001763 | 80  | 12   | 2.634           |
| 148 | BAR001764 | 80  | 15   | 3.284           |
| 149 | BAR001765 | 80  | 16   | 3.501           |
| 150 | BAR001766 | 80  | 20   | 4.368           |
| 151 | BAR001579 | 85  | 10   | 2.337           |
| 152 | BAR001580 | 85  | 15   | 3.489           |
| 153 | BAR001581 | 85  | 25   | 5.816           |
| 154 | BAR001582 | 85  | 30   | 6.910           |
| 155 | BAR001583 | 85  | 35   | 8.119           |
| 156 | BAR001584 | 85  | 40   | 9.271           |
| 157 | BAR001866 | 85  | 11   | 2.683           |
| 158 | BAR001778 | 90  | 8    | 1.987           |
| 159 | BAR001779 | 90  | 10   | 2.438           |
| 160 | BAR001780 | 90  | 12   | 2.963           |
| 161 | BAR001781 | 90  | 13   | 3.207           |
| 162 | BAR001782 | 90  | 15   | 3.695           |
| 163 | BAR001783 | 90  | 16   | 3.938           |
| 164 | BAR001784 | 90  | 20   | 4.914           |
| 165 | BAR001871 | 90  | 6    | 1.499           |
| 166 | BAR001590 | 95  | 30   | 7.787           |
| 167 | BAR001591 | 95  | 40   | 10.362          |
| 168 | BAR001797 | 100 | 5    | 1.395           |
| 169 | BAR001798 | 100 | 6    | 1.666           |
| 170 | BAR001799 | 100 | 8    | 2.208           |
| 171 | BAR001800 | 100 | 10   | 2.750           |
| 172 | BAR001801 | 100 | 12   | 3.292           |
| 173 | BAR001883 | 100 | 15   | 4.105           |
| 174 | BAR001885 | 100 | 16   | 4.376           |
| 175 | BAR001886 | 100 | 18   | 4.918           |
| 176 | BAR001809 | 103 | 15   | 4.228           |
| 177 | BAR001813 | 107 | 13.5 | 3.958           |
| 178 | BAR001816 | 110 | 10   | 3.025           |
| 179 | BAR001817 | 110 | 12   | 3.621           |
| 180 | BAR001818 | 110 | 15   | 4.516           |

| No  | DIES No   | A   | B  | U-Weight (Kg/m) |
|-----|-----------|-----|----|-----------------|
| 181 | BAR001819 | 110 | 16 | 4.814           |
| 182 | BAR001830 | 116 | 13 | 4.133           |
| 183 | B00010050 | 120 | 50 | 16.251          |
| 184 | BAR001831 | 120 | 10 | 3.300           |
| 185 | BAR001912 | 120 | 12 | 3.951           |
| 186 | BAR001915 | 120 | 15 | 4.926           |
| 187 | BAR012525 | 125 | 25 | 8.468           |
| 188 | BAR001838 | 130 | 10 | 3.570           |
| 189 | BAR001839 | 130 | 12 | 4.280           |
| 190 | BAR001852 | 140 | 9  | 3.471           |
| 191 | BAR015025 | 150 | 25 | 10.163          |
| 192 | BAR016040 | 160 | 40 | 17.350          |
| 193 | BAR020025 | 200 | 25 | 13.550          |



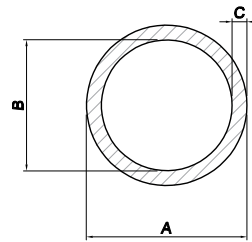
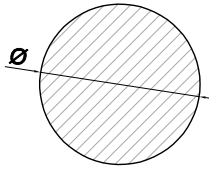

| No | DIES No   | Ø    | U-Weight (Kg/m) |
|----|-----------|------|-----------------|
| 1  | ROU001180 | 4    | 0.037           |
| 2  | ROU001181 | 5    | 0.056           |
| 3  | ROU001182 | 6    | 0.081           |
| 4  | ROU001183 | 7    | 0.109           |
| 5  | ROU001184 | 8    | 0.141           |
| 6  | ROU001185 | 9    | 0.178           |
| 7  | ROU001186 | 10   | 0.219           |
| 8  | ROU001187 | 11   | 0.265           |
| 9  | ROU001188 | 12   | 0.314           |
| 10 | ROU001189 | 13   | 0.368           |
| 11 | ROU001190 | 14   | 0.426           |
| 12 | ROU001191 | 15   | 0.489           |
| 13 | ROU001192 | 16   | 0.555           |
| 14 | ROU001193 | 18   | 0.701           |
| 15 | ROU001194 | 19   | 0.781           |
| 16 | ROU001014 | 20   | 0.851           |
| 17 | ROU001196 | 21   | 0.961           |
| 18 | ROU001197 | 22   | 1.054           |
| 19 | ROU001198 | 23   | 1.151           |
| 20 | ROU001199 | 24   | 1.252           |
| 21 | ROU001200 | 25   | 1.357           |
| 22 | ROU001201 | 26   | 1.467           |
| 23 | ROU001202 | 28   | 1.699           |
| 24 | ROU001203 | 30   | 1.948           |
| 25 | ROU001204 | 32   | 2.214           |
| 26 | ROU001205 | 35   | 2.645           |
| 27 | ROU001206 | 36   | 2.797           |
| 28 | ROU001207 | 38   | 3.114           |
| 29 | ROU001208 | 40   | 3.448           |
| 30 | ROU001209 | 42   | 3.799           |
| 31 | ROU001210 | 47.5 | 4.853           |
| 32 | ROU001211 | 48   | 4.955           |

| No | DIES No   | A  | B    | C   | U-Weight (Kg/m) |
|----|-----------|----|------|-----|-----------------|
| 1  | 008PR0008 | 8  | 6.4  | 0.8 | 0.049           |
| 2  | 012PR0012 | 12 | 10.4 | 0.8 | 0.076           |
| 3  | 016PR0016 | 16 | 13.6 | 1.2 | 0.151           |
| 4  | 019PR0019 | 19 | 17.2 | 0.9 | 0.139           |
| 5  | 019PIP019 | 19 | 16.8 | 1.1 | 0.168           |
| 6  | 025PR0025 | 25 | 23   | 1.0 | 0.204           |
| 7  | PIP0R034A | 34 | 28   | 3.0 | 0.792           |

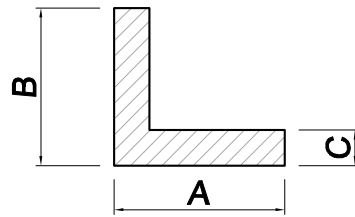

| No | DIES No    | A  | B  | C   | U-Weight<br>(Kg/m) |
|----|------------|----|----|-----|--------------------|
| 1  | 012AG0012  | 12 | 12 | 0.7 | 0.044              |
| 2  | ANG0001544 | 13 | 40 | 2.0 | 0.276              |
| 3  | 015AG015A  | 15 | 15 | 1.5 | 0.116              |
| 4  | 020AG0020  | 20 | 20 | 1.2 | 0.126              |
| 5  | 020AG020B  | 20 | 20 | 2.0 | 0.206              |
| 6  | 020AG020A  | 20 | 20 | 3.0 | 0.301              |
| 7  | MUL0008334 | 22 | 33 | 4.0 | 0.552              |
| 8  | 025AG0025  | 25 | 25 | 0.7 | 0.093              |
| 9  | 025AG025A  | 25 | 25 | 3.0 | 0.382              |
| 10 | 025AG0030  | 25 | 30 | 1.1 | 0.160              |
| 11 | 025AG0038  | 25 | 38 | 1.0 | 0.166              |
| 12 | 025AG0050B | 25 | 50 | 3.0 | 0.585              |
| 13 | ATMU02041  | 30 | 15 | 2.0 | 0.234              |
| 14 | 030AG0030  | 30 | 30 | 1.1 | 0.175              |
| 15 | 030AG030A  | 30 | 30 | 3.0 | 0.463              |
| 16 | ANG0001545 | 30 | 50 | 2.0 | 0.423              |
| 17 | 035AG035A  | 35 | 35 | 3.0 | 0.544              |
| 18 | 038AG0038  | 38 | 38 | 1.0 | 0.203              |
| 19 | 038AG0075  | 38 | 75 | 1.2 | 0.363              |
| 20 | 040AG0040  | 40 | 40 | 3.0 | 0.725              |
| 21 | HAB000406  | 45 | 45 | 4.0 | 0.932              |
| 22 | 050AG0050  | 50 | 50 | 1.2 | 0.329              |
| 23 | 050AG050B  | 50 | 50 | 3.0 | 0.789              |
| 24 | EX0000480  | 50 | 50 | 4.0 | 1.041              |
| 25 | 050AG0060  | 50 | 60 | 3.0 | 0.870              |





## INDONESIA PROFILE

Một số profile phổ biến cho thị trường Indonesia. Từng bước xâm nhập và chiếm lĩnh thị trường Indonesia. Tiếp tục nghiên cứu và đưa ra sản phẩm đa dạng và phù hợp hơn với thị trường Indonesia nói riêng và thị trường Đông Nam Á nói chung.

# SHOP FRONT 3 INCH ASSEMBLY

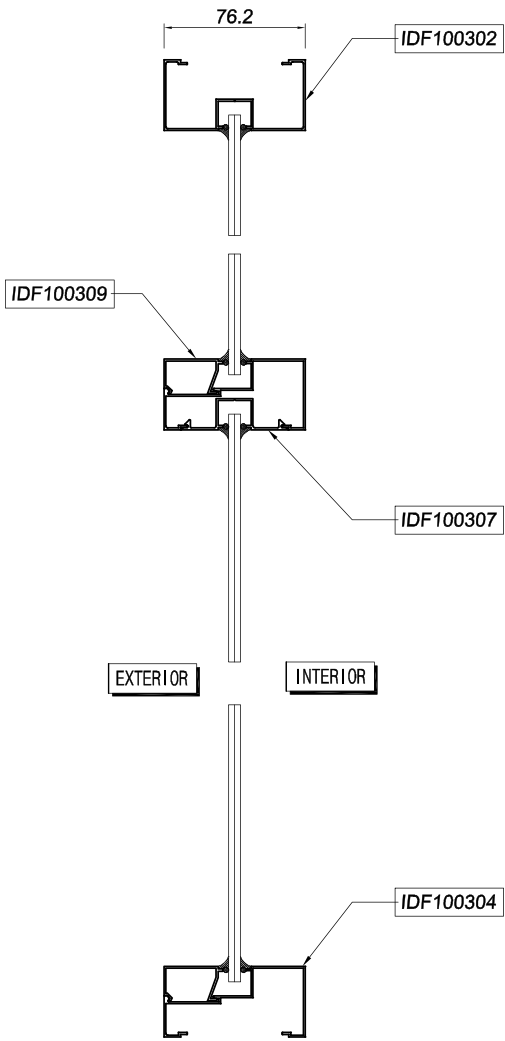

**1**  
SE-01  
*Vertical Section Detail*  
SCALE : NONE

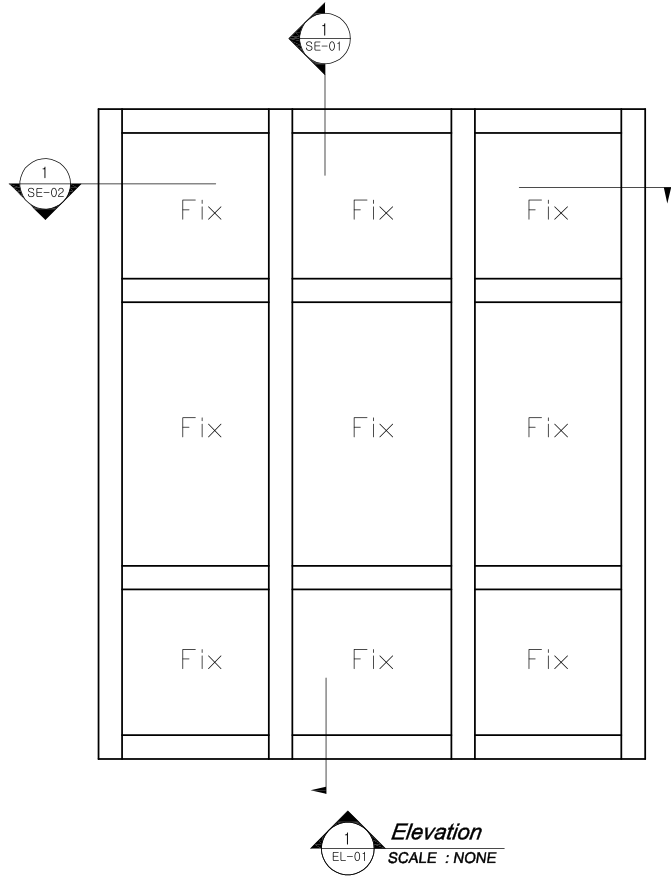

**1**  
EL-01  
*Elevation*  
SCALE : NONE

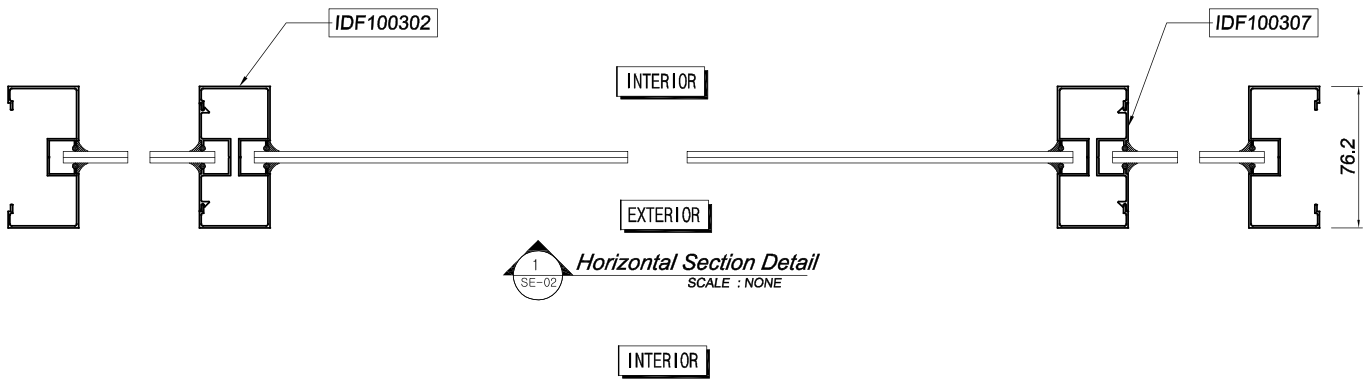

**1**  
SE-02  
*Horizontal Section Detail*  
SCALE : NONE

★ THK: 1.0 MM

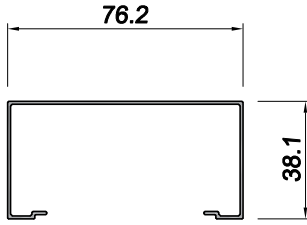

**IDF100306**  
THK. 1.0 mm - 0.48 Kg/m

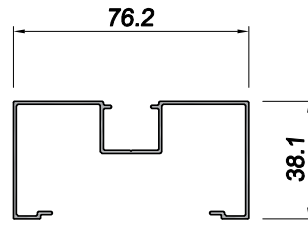

**IDF100302**  
THK. 1.0 mm - 0.58 Kg/m

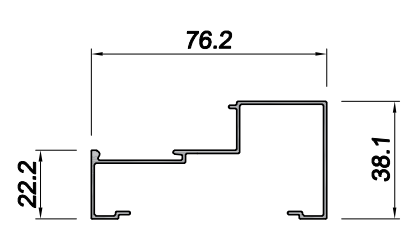

**IDF100304**  
THK. 1.0 mm - 0.518 Kg/m

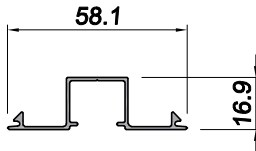

**IDF100307**  
THK. 1.0 mm - 0.303 Kg/m

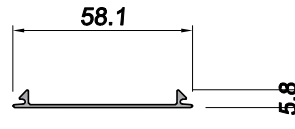

**IDF100308**  
THK. 1.0 mm - 0.202 Kg/m

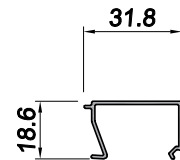

**IDF100309**  
THK. 1.0 mm - 0.202 Kg/m

★ THK: 1.1 MM

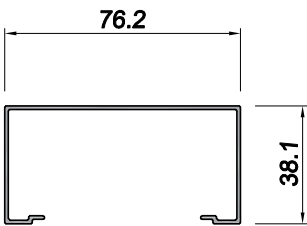

**IDF110306**  
THK. 1.1 mm - 0.526 Kg/m

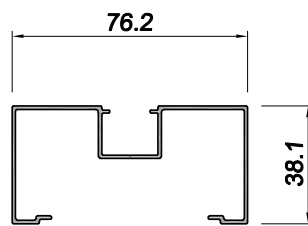

**IDF110302**  
THK. 1.1 mm - 0.635 Kg/m

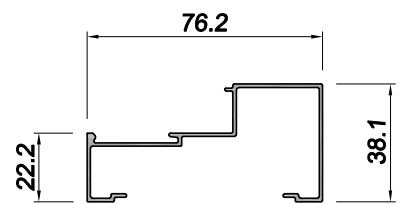

**IDF110304**  
THK. 1.1 mm - 0.565 Kg/m

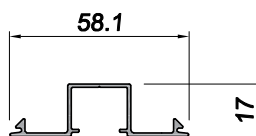

**IDF110307**  
THK. 1.1 mm - 0.325 Kg/m

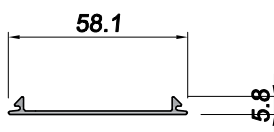

**IDF110308**  
THK. 1.1 mm - 0.216 Kg/m

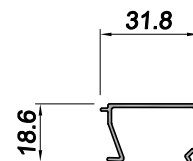

**IDF110309**  
THK. 1.1 mm - 0.220 Kg/m



★ THK: 1.15 MM

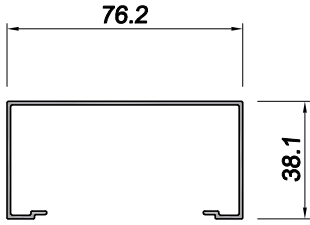

**IDF115306**  
THK. 1.15 mm - 0.550 Kg/m

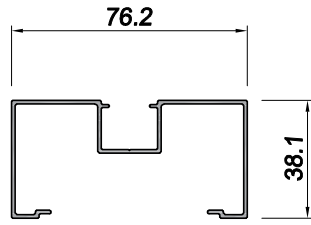

**IDF115302**  
THK. 1.15 mm - 0.663 Kg/m

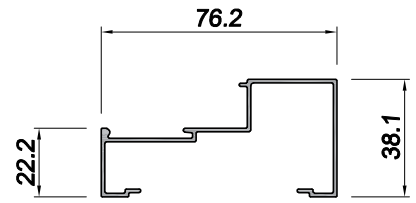

**IDF115304**  
THK. 1.15 mm - 0.583 Kg/m

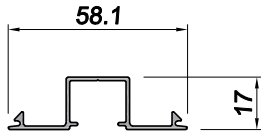

**IDF115307**  
THK. 1.15 mm - 0.336 Kg/m

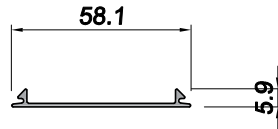

**IDF115308**  
THK. 1.15 mm - 0.222 Kg/m

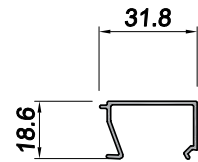

**IDF115309**  
THK. 1.15 mm - 0.229 Kg/m

★ THK: 1.3 MM

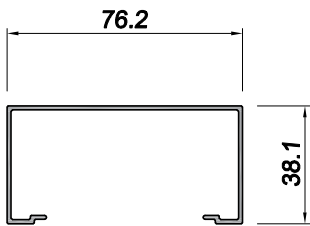

**IDF130306**  
THK. 1.3 mm - 0.619 Kg/m

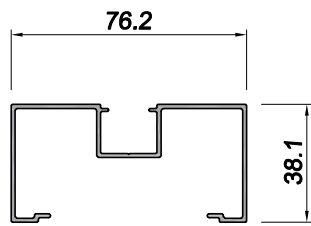

**IDF130302**  
THK. 1.3 mm - 0.745 Kg/m

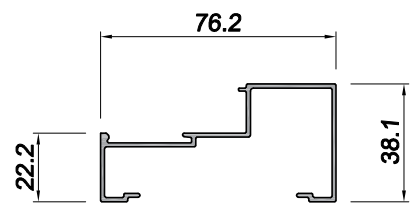

**IDF130304**  
THK. 1.3 mm - 0.658 Kg/m

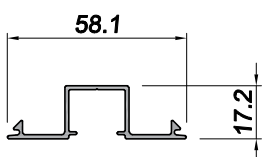

**IDF130307**  
THK. 1.3 mm - 0.370 Kg/m

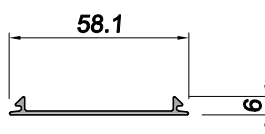

**IDF130308**  
THK. 1.3 mm - 0.243 Kg/m

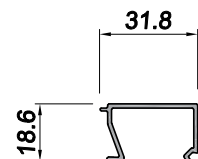

**IDF130309**  
THK. 1.3 mm - 0.260 Kg/m

# SHOP FRONT 4 INCH & SWING DOOR ASSEMBLY

Công nghệ làm nên tương lai phần vịnh

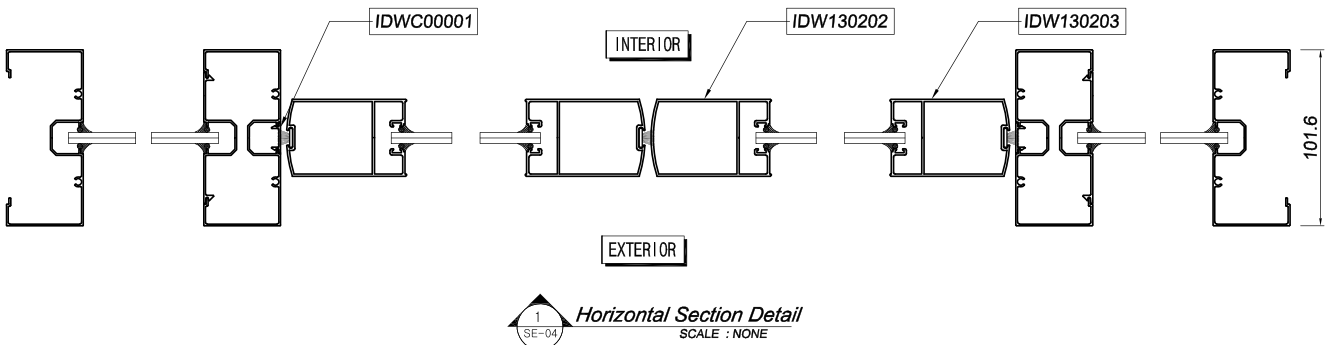
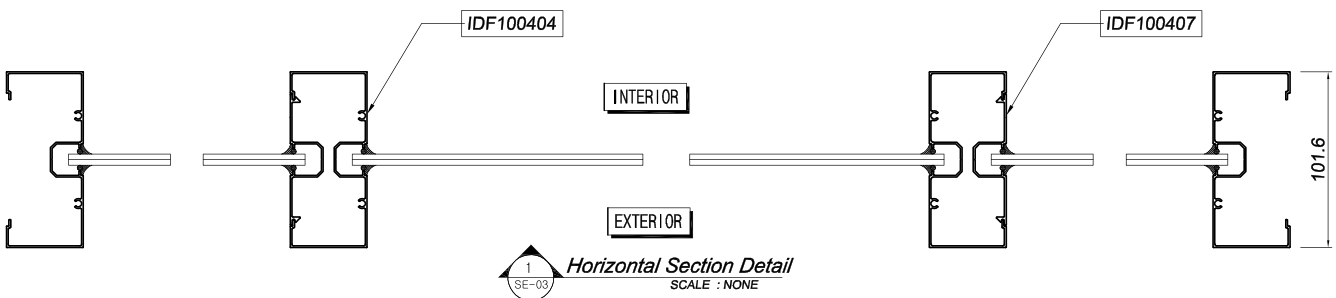
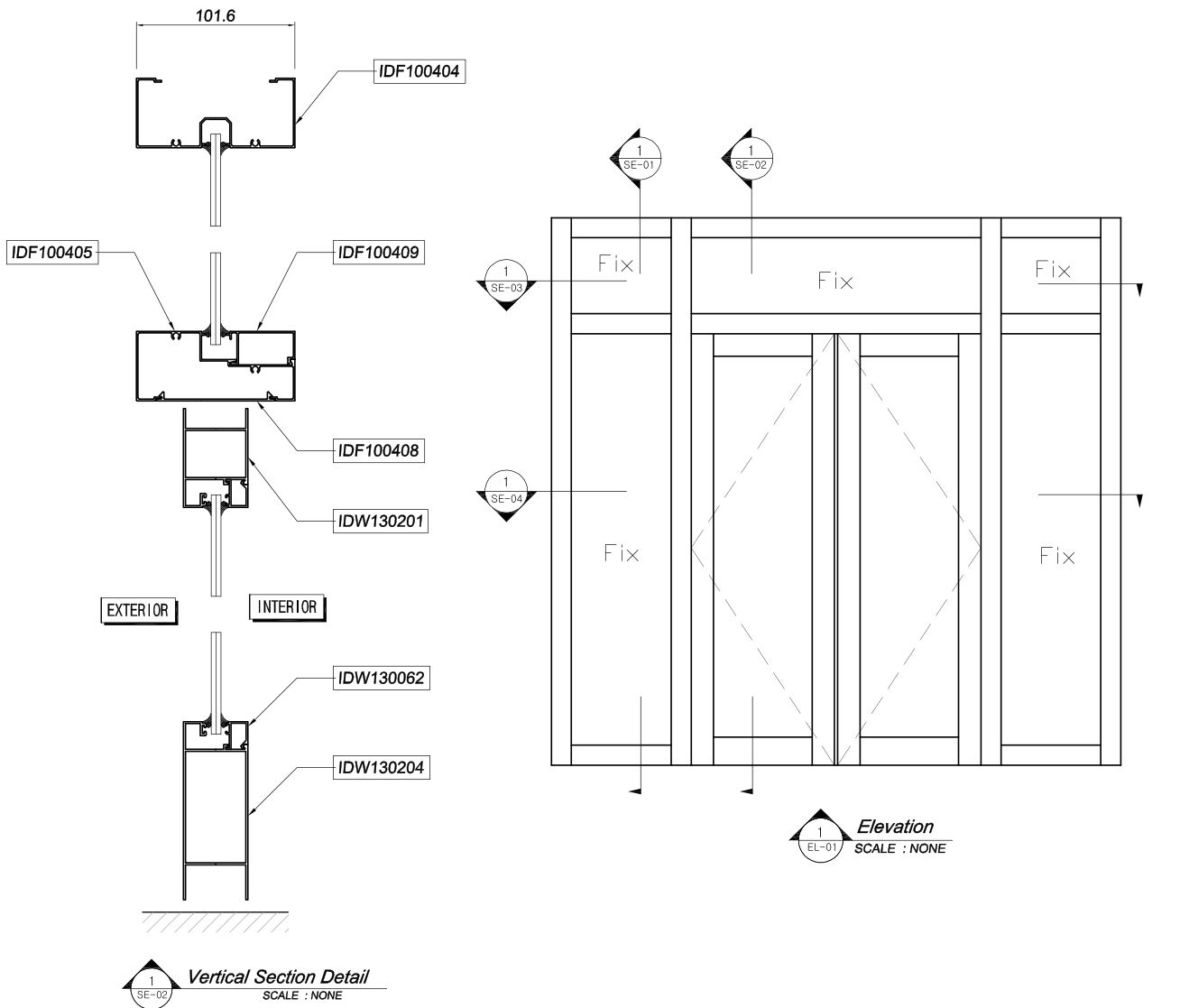



## ★ THK: 1.1 MM

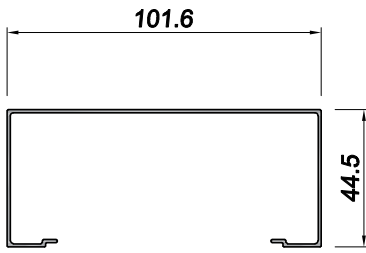

**IDF100406**  
THK. 1.0 mm - 0.604 Kg/m

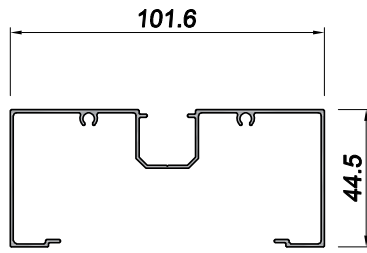

**IDF100404**  
THK. 1.0 mm - 0.759 Kg/m

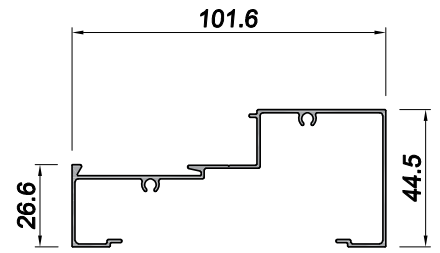

**IDF100405**  
THK. 1.0 mm - 0.705 Kg/m

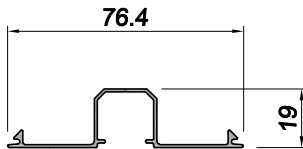

**IDF100407**  
THK. 1.0 mm - 0.355 Kg/m

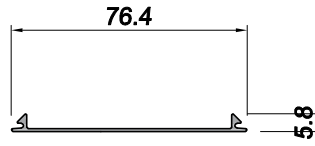

**IDF100408**  
THK. 1.0 mm - 0.252 Kg/m

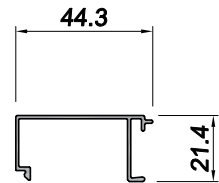

**IDF100409**  
THK. 1.0 mm - 0.273 Kg/m

## ★ THK: 1.15 MM

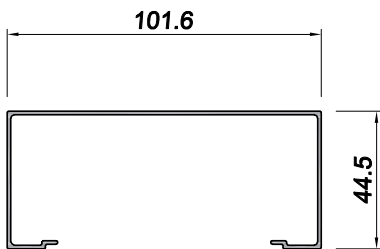

**IDF115406**  
THK. 1.15 mm - 0.692 Kg/m

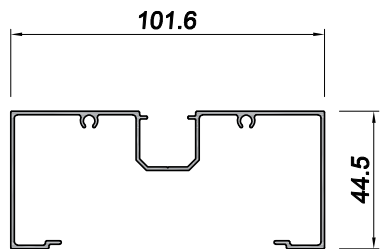

**IDF115404**  
THK. 1.15 mm - 0.860 Kg/m

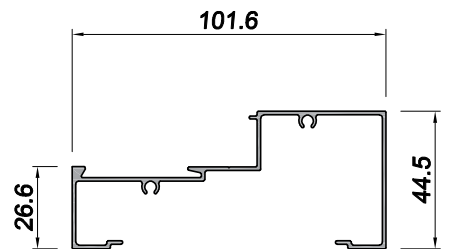

**IDF115405**  
THK. 1.15 mm - 0.805 Kg/m

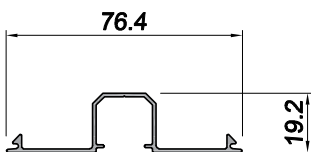

**IDF115407**  
THK. 1.15 mm - 0.396 Kg/m

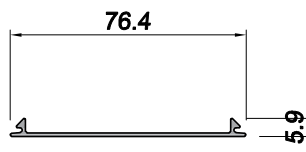

**IDF115408**  
THK. 1.15 mm - 0.279 Kg/m

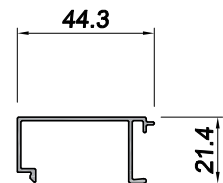

**IDF115409**  
THK. 1.15 mm - 0.306 Kg/m

★ THK: 1.25 MM

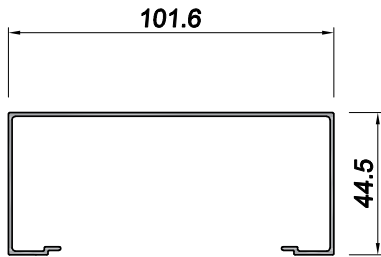

**IDF125406**  
THK. 1.25 mm - 0.751 Kg/m

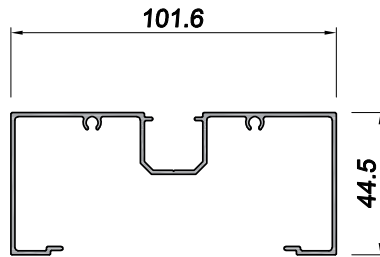

**IDF125404**  
THK. 1.25 mm - 0.927 Kg/m

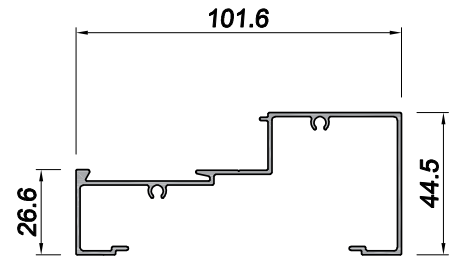

**IDF125405**  
THK. 1.25 mm - 0.863 Kg/m

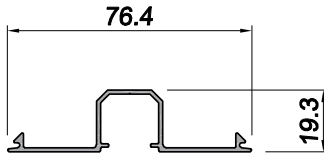

**IDF125407**  
THK. 1.25 mm - 0.423 Kg/m

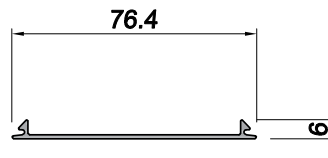

**IDF125408**  
THK. 1.25 mm - 0.298 Kg/m

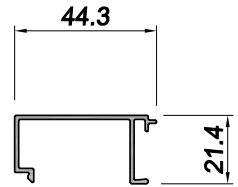

**IDF125409**  
THK. 1.25 mm - 0.327 Kg/m

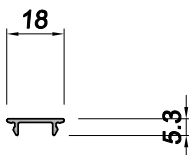

**IDWC00001**  
THK. 1.0 mm - 0.077 Kg/m

★ THK: 1.3 MM

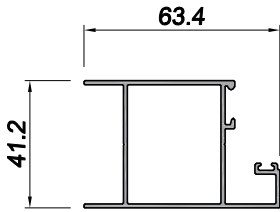

**IDW130201**  
THK. 1.3 mm - 0.771 Kg/m

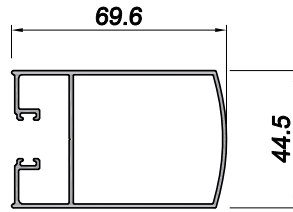

**IDW130202**  
THK. 1.3 mm - 0.93 Kg/m

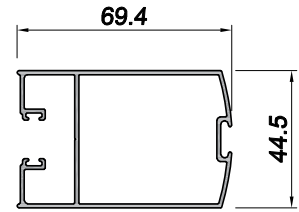

**IDW130203**  
THK. 1.3 mm - 0.965 Kg/m

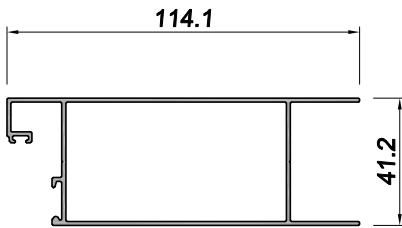

**IDW130204**  
THK. 1.3 mm - 1.129 Kg/m

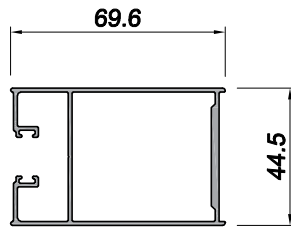

**IDW130730**  
THK. 1.3 mm - 1.057 Kg/m

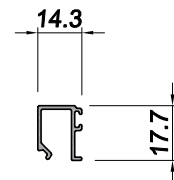

**IDW130062**  
THK. 1.1 mm - 0.167 Kg/m

★ THK: 1.4 MM

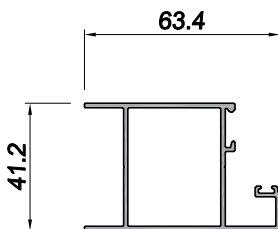

**IDW140201**  
THK. 1.4 mm - 0.823 Kg/m

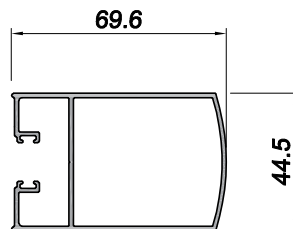

**IDW140202**  
THK. 1.4 mm - 0.992 Kg/m

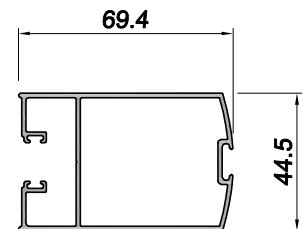

**IDW140203**  
THK. 1.4 mm - 1.027 Kg/m

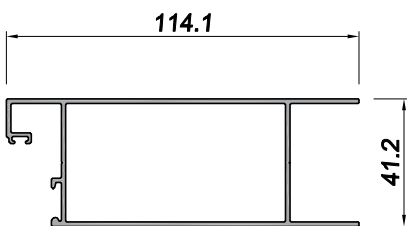

**IDW140204**  
THK. 1.4 mm - 1.208 Kg/m

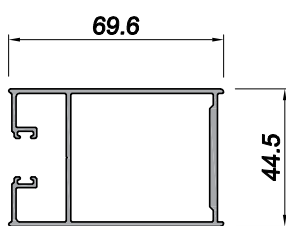

**IDW140730**  
THK. 1.4 mm - 1.111 Kg/m

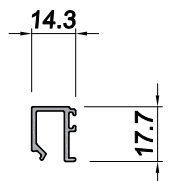

**IDW140062**  
THK. 1.4 mm - 0.201 Kg/m

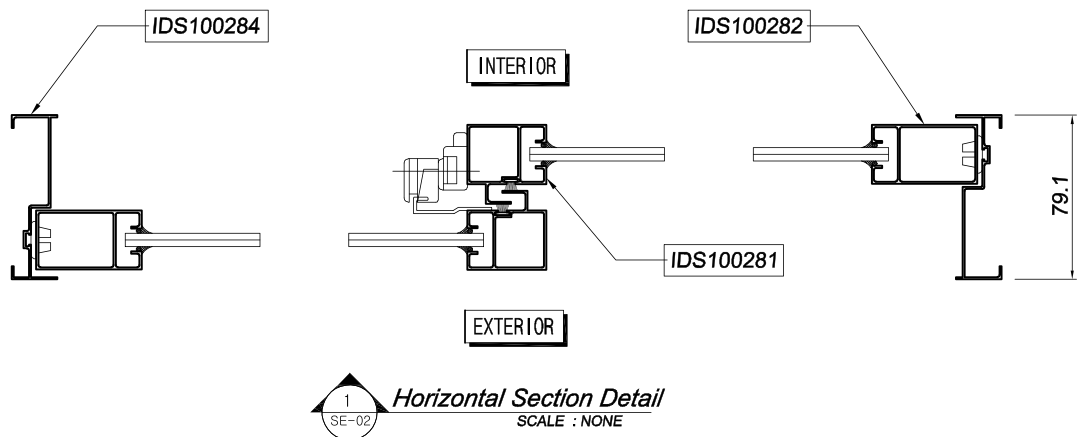
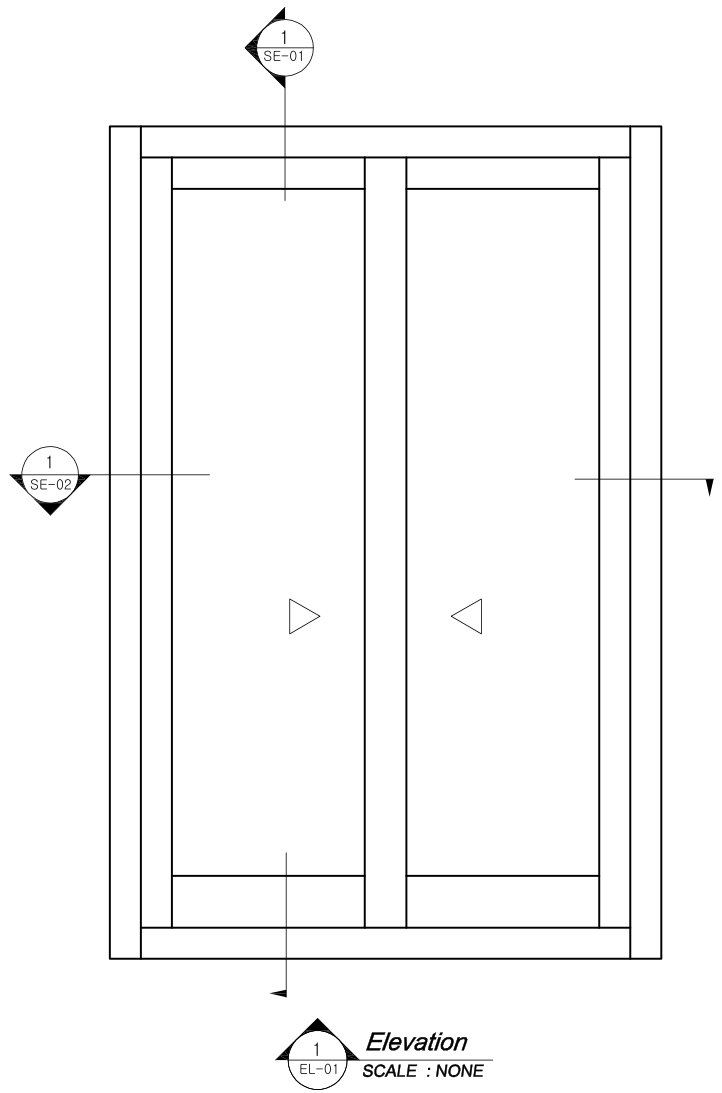
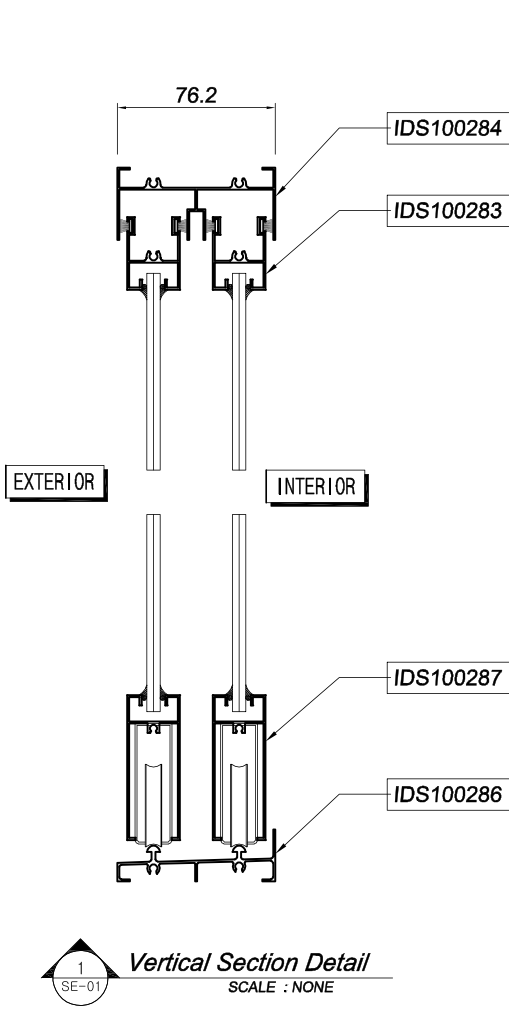

★ THK: 1.0 MM

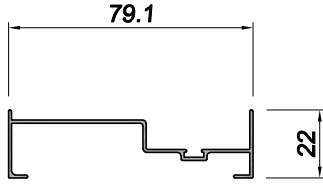

**IDS100284**  
THK. 1.0 mm - 0.401 Kg/m

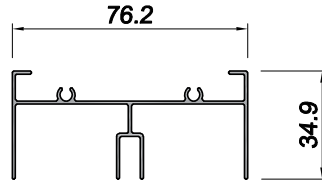

**IDS100285**  
THK. 1.0 mm - 0.597 Kg/m

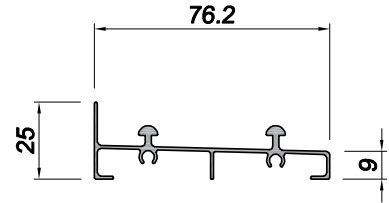

**IDS100286**  
THK. 1.0 mm - 0.543 Kg/m

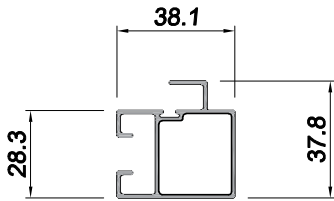

**IDS100281**  
THK. 1.0 mm - 0.488 Kg/m

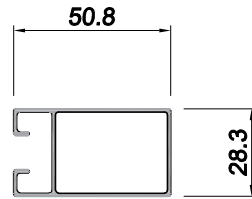

**IDS100282**  
THK. 1.0 mm - 0.485 Kg/m

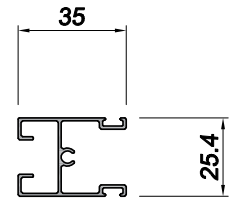

**IDS100283**  
THK. 1.0 mm - 0.374 Kg/m

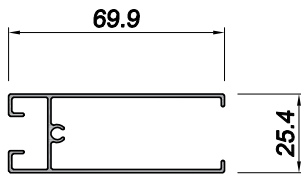

**IDS100287**  
THK. 1.0 mm - 0.541 Kg/m

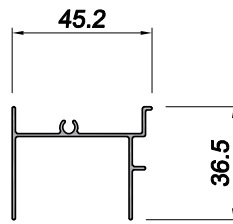

**IDS100289**  
THK. 1.0 mm - 0.354 Kg/m

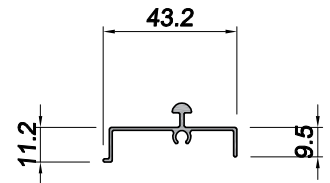

**IDS100295**  
THK. 1.0 mm - 0.255 Kg/m

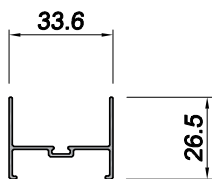

**IDS100288**  
THK. 1.0 mm - 0.254 Kg/m

★ THK: 1.05 MM

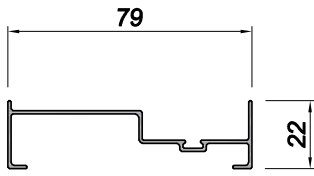

**IDS105284**  
THK. 1.05 mm - 0.422 Kg/m

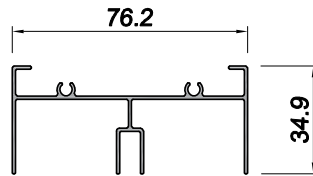

**IDS105285**  
THK. 1.05 mm - 0.622 Kg/m

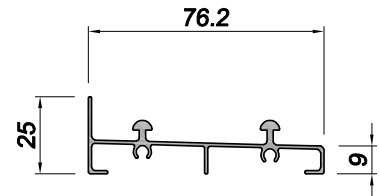

**IDS105286**  
THK. 1.05 mm - 0.558 Kg/m

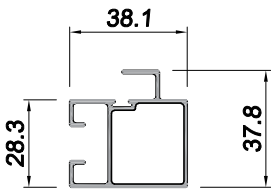

**IDS105281**  
THK. 1.05 mm - 0.509 Kg/m

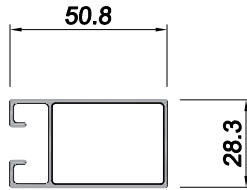

**IDS105282**  
THK. 1.05 mm - 0.508 Kg/m

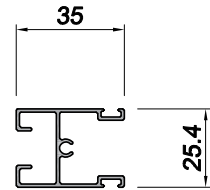

**IDS105283**  
THK. 1.05 mm - 0.389 Kg/m

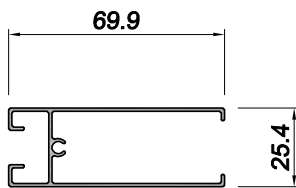

**IDS105287**  
THK. 1.05 mm - 0.565 Kg/m

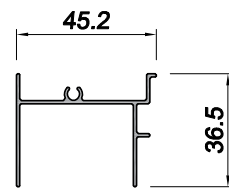

**IDS105289**  
THK. 1.05 mm - 0.371 Kg/m

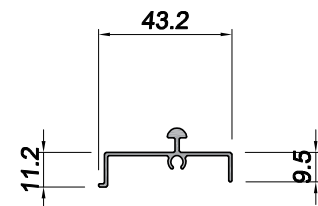

**IDS105295**  
THK. 1.05 mm - 0.263 Kg/m

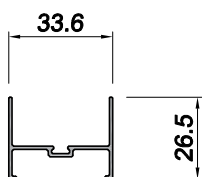

**IDS105288**  
THK. 1.05 mm - 0.266 Kg/m

★ THK: 1.1 MM

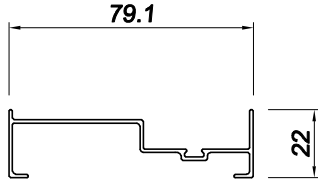

**IDS110284**  
THK. 1.1 mm - 0.441 Kg/m

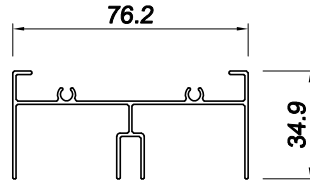

**IDS110285**  
THK. 1.1 mm - 0.647 Kg/m

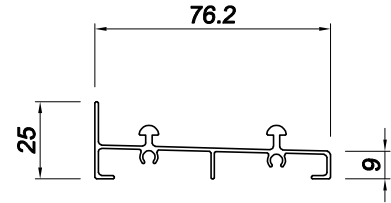

**IDS110286**  
THK. 1.1 mm - 0.573 Kg/m

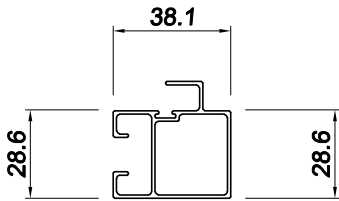

**IDS110281**  
THK. 1.1 mm - 0.532 Kg/m

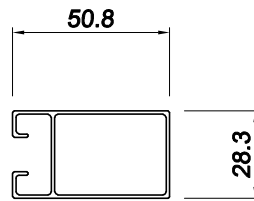

**IDS110282**  
THK. 1.1 mm - 0.531 Kg/m

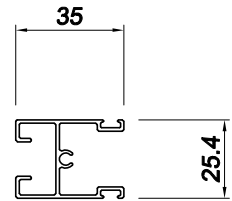

**IDS110283**  
THK. 1.1 mm - 0.404 Kg/m

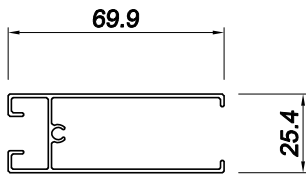

**IDS110287**  
THK. 1.1 mm - 0.589 Kg/m

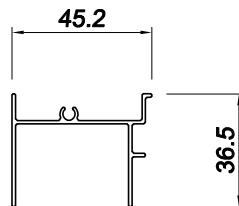

**IDS110289**  
THK. 1.1 mm - 0.386 Kg/m

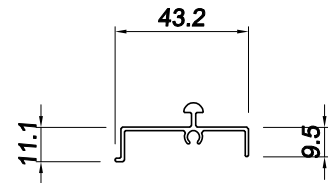

**IDS110295**  
THK. 1.1 mm - 0.271 Kg/m

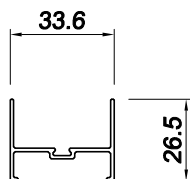

**IDS110288**  
THK. 1.1 mm - 0.278 Kg/m



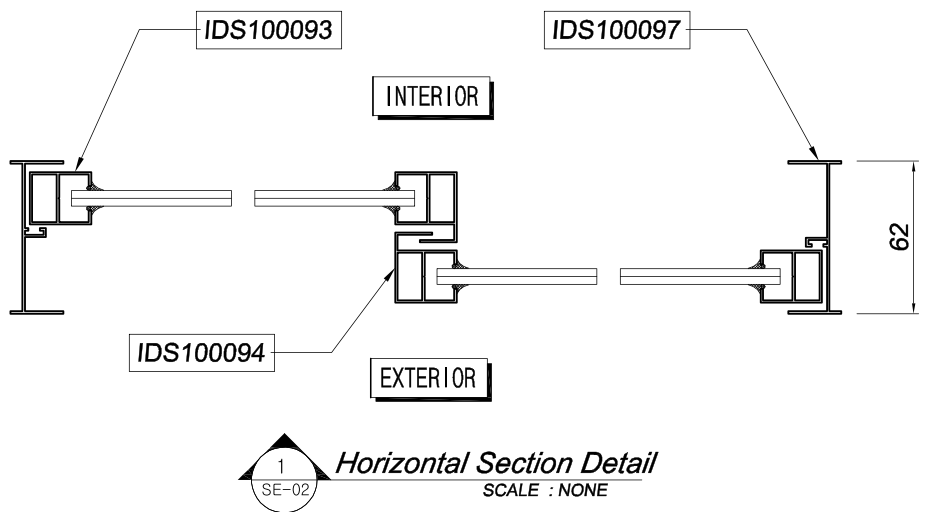
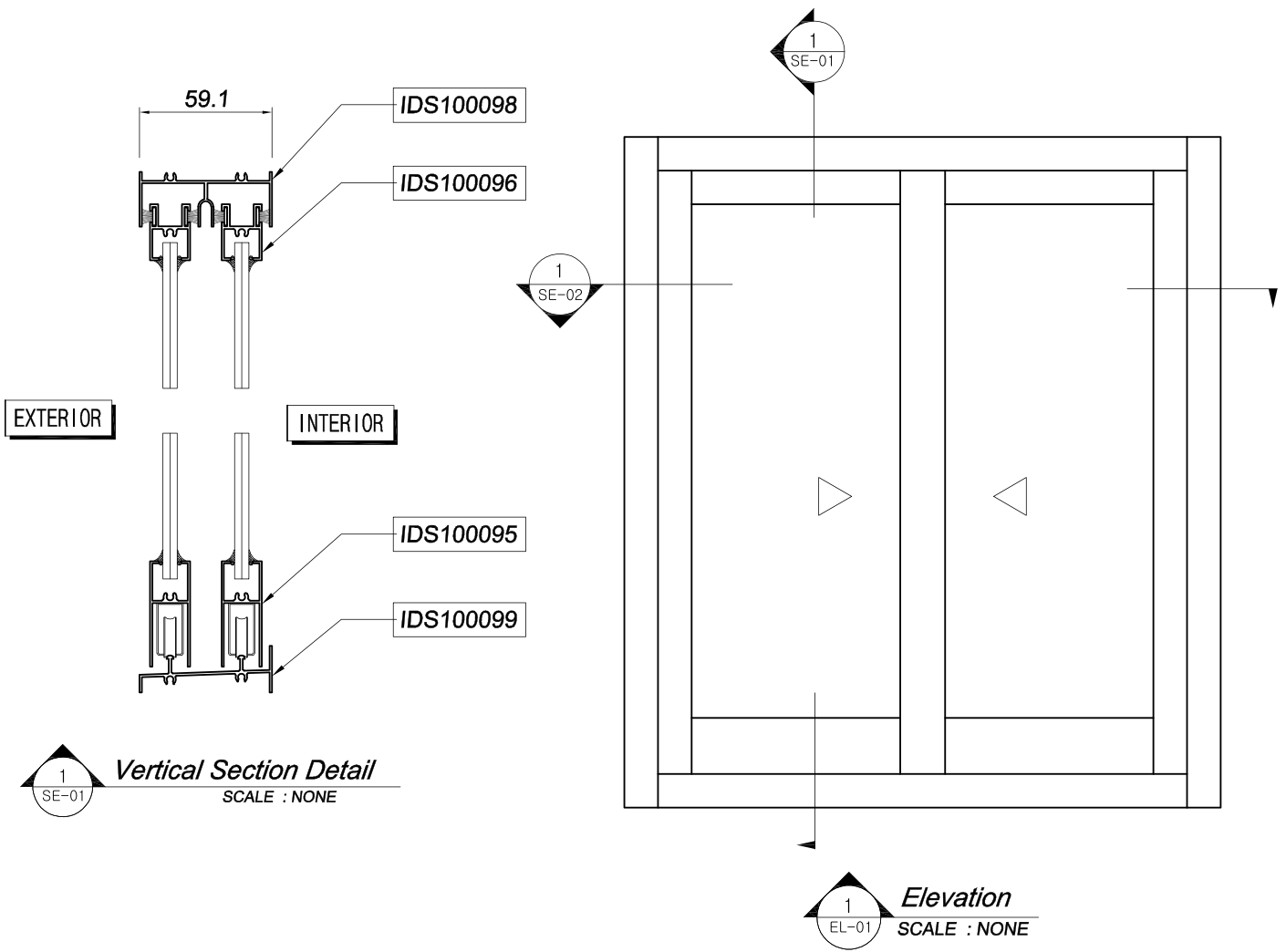

★ THK: 1.0 MM

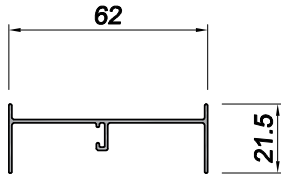

**IDS100097**  
THK. 1.0 mm - 0.317 Kg/m

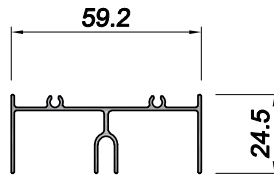

**IDS100098**  
THK. 1.0 mm - 0.433 Kg/m

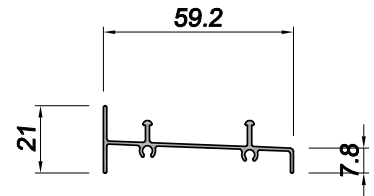

**IDS100099**  
THK. 1.0 mm - 0.341 Kg/m

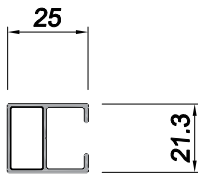

**IDS100093**  
THK. 1.0 mm - 0.265 Kg/m

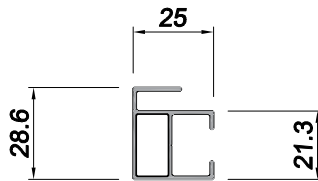

**IDS100094**  
THK. 1.0 mm - 0.323 Kg/m

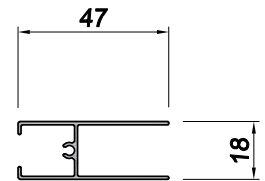

**IDS100095**  
THK. 1.0 mm - 0.336 Kg/m

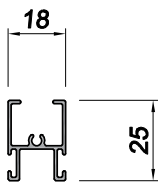

**IDS100096**  
THK. 1.0 mm - 0.252 Kg/m

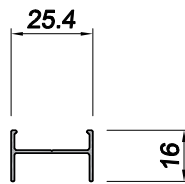

**IDS100109**  
THK. 1.0 mm - 0.154 Kg/m

★ THK: 1.05 MM

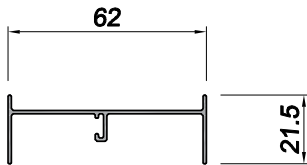

**IDS105097**  
THK. 1.05 mm - 0.333 Kg/m

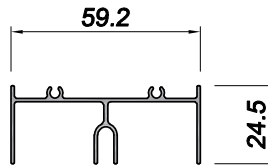

**IDS105098**  
THK. 1.05 mm - 0.446 Kg/m

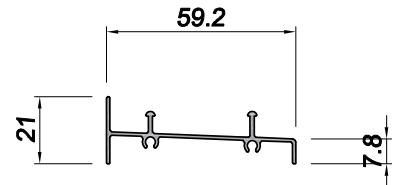

**IDS105099**  
THK. 1.05 mm - 0.352 Kg/m

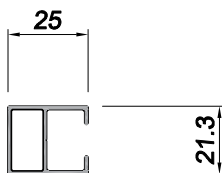

**IDS105093**  
THK. 1.05 mm - 0.278 Kg/m

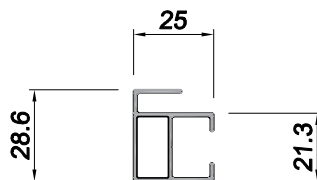

**IDS105094**  
THK. 1.05 mm - 0.338 Kg/m

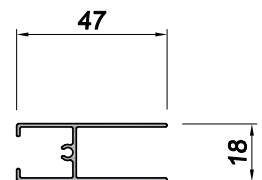

**IDS105095**  
THK. 1.05 mm - 0.351 Kg/m

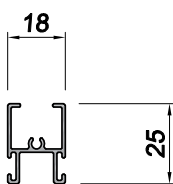

**IDS105096**  
THK. 1.05 mm - 0.262 Kg/m

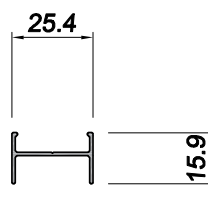

**IDS105109**  
THK. 1.05 mm - 0.161 Kg/m

★ THK: 1.1 MM

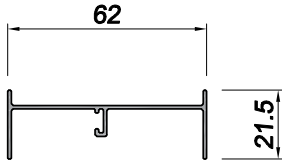

**IDS110097**  
THK. 1.1 mm - 0.347 Kg/m

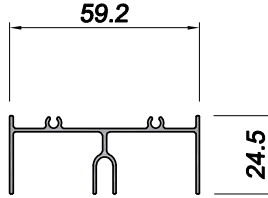

**IDS110098**  
THK. 1.1 mm - 0.460 Kg/m

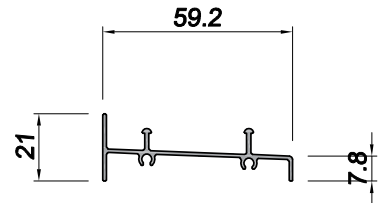

**IDS110099**  
THK. 1.1 mm - 0.364 Kg/m

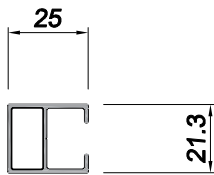

**IDS110093**  
THK. 1.1 mm - 0.290 Kg/m

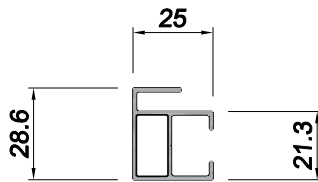

**IDS110094**  
THK. 1.1 mm - 0.353 Kg/m

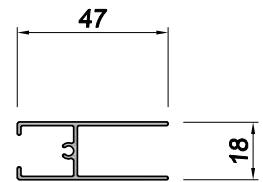

**IDS110095**  
THK. 1.1 mm - 0.366 Kg/m

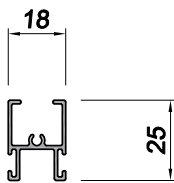

**IDS110096**  
THK. 1.1 mm - 0.272 Kg/m

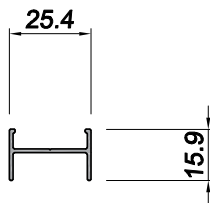

**IDS110109**  
THK. 1.1 mm - 0.168 Kg/m

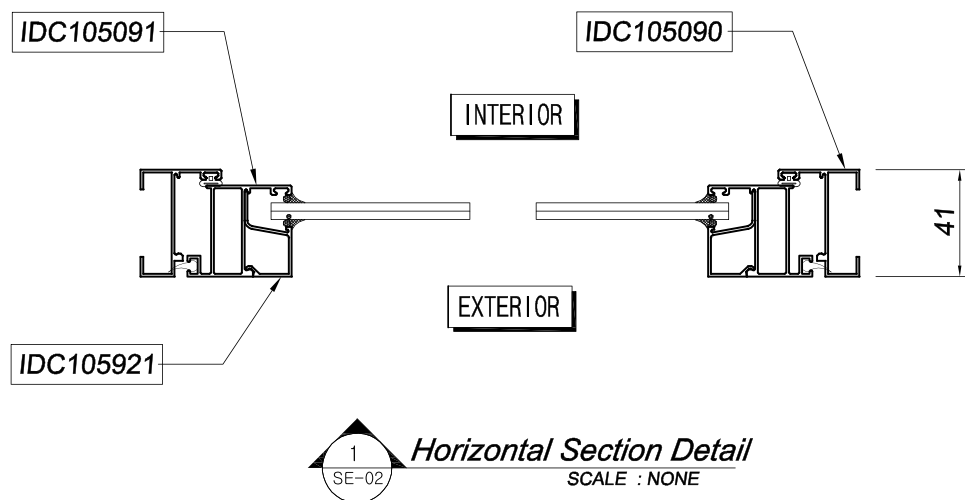
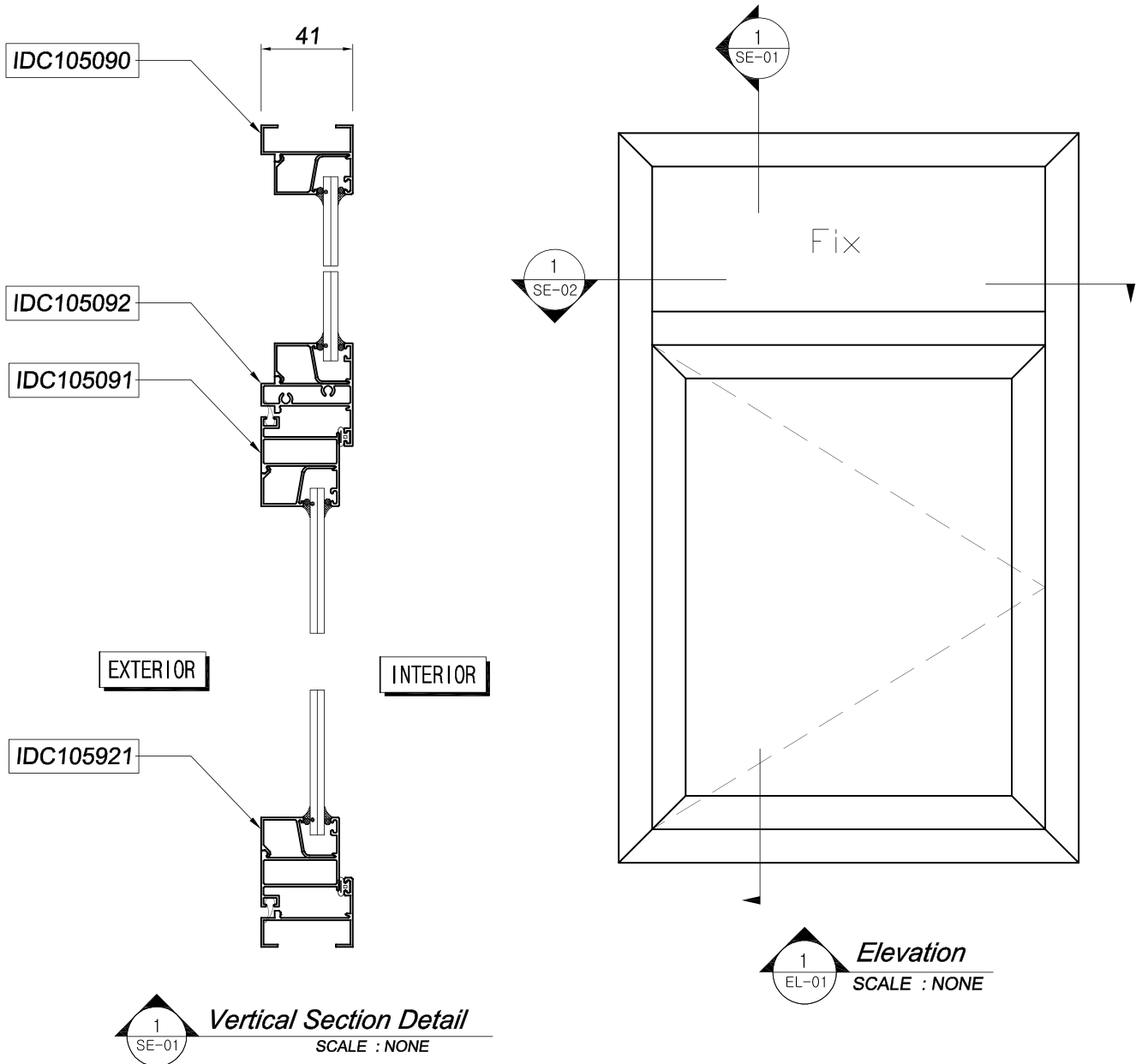

## ★ THK: 1.05 MM

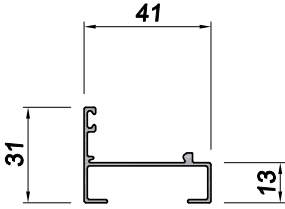

**IDC105090**  
THK. 1.05 mm - 0.326 Kg/m

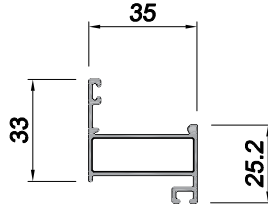

**IDC105091**  
THK. 1.05 mm - 0.436 Kg/m

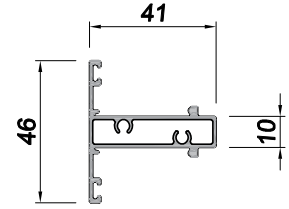

**IDC105092**  
THK. 1.05 mm - 0.542 Kg/m

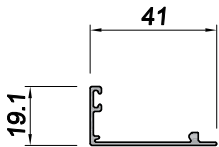

**IDC105733**  
THK. 1.05 mm - 0.221 Kg/m

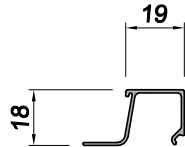

**IDC105921**  
THK. 1.05 mm - 0.190 Kg/m

## ★ THK: 1.2 MM

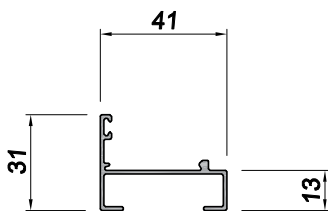

**IDC120090**  
THK. 1.2 mm - 0.361 Kg/m

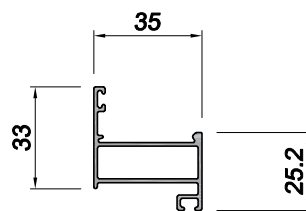

**IDC120091**  
THK. 1.2 mm - 0.480 Kg/m

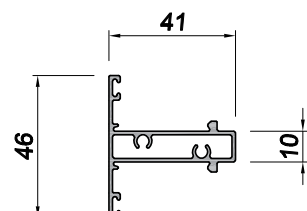

**IDC120092**  
THK. 1.2 mm - 0.591 Kg/m

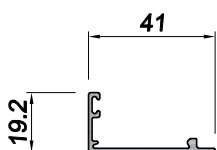

**IDC120733**  
THK. 1.2 mm - 0.243 Kg/m

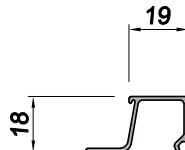

**IDC120921**  
THK. 1.2 mm - 0.224 Kg/m

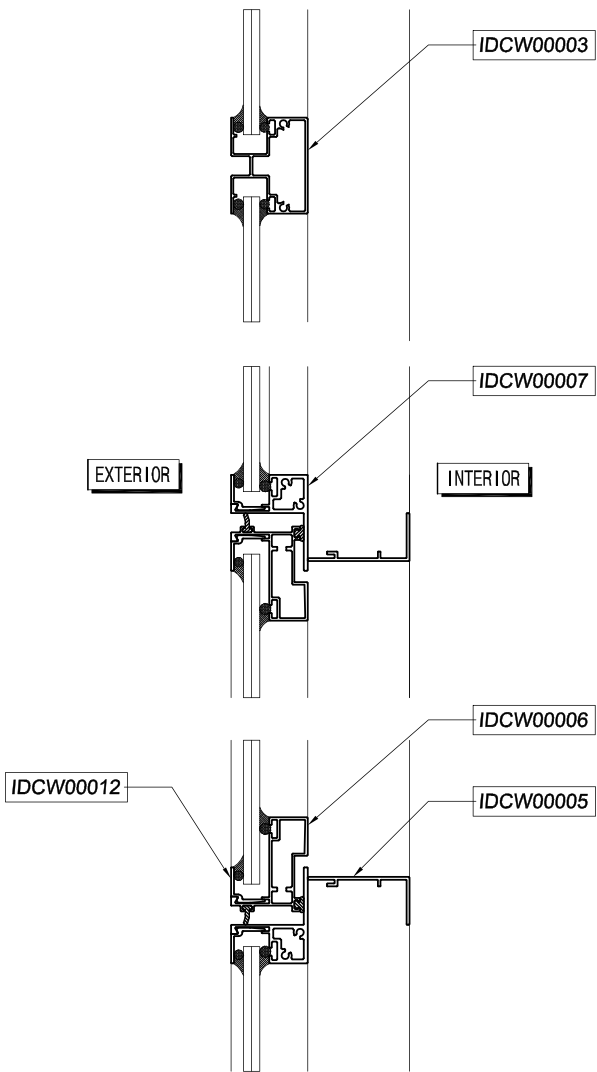

1 SE-01 Vertical Section Detail  
SCALE : NONE

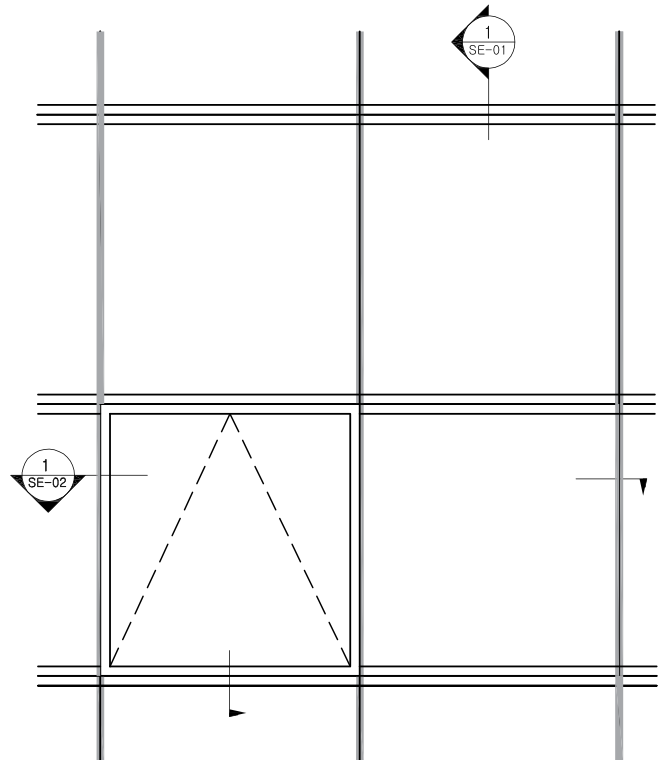

1 EL-01 Project & Fix Elevation  
SCALE : NONE

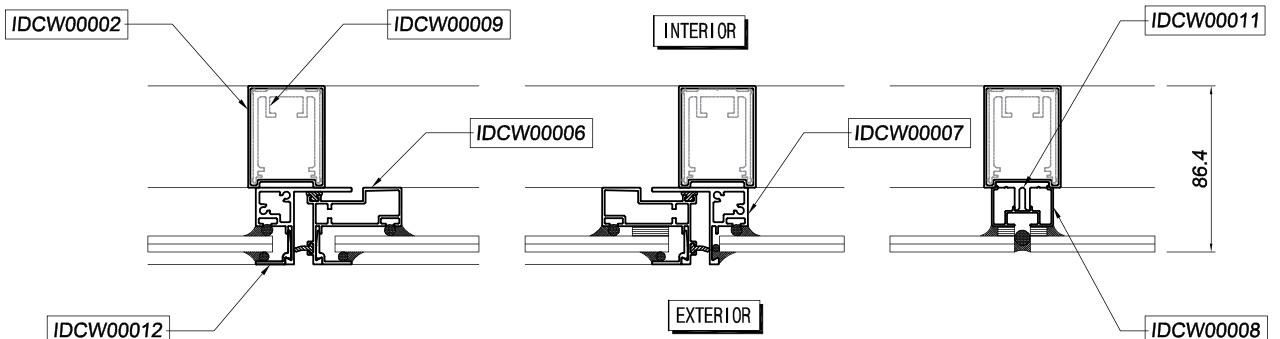

1 SE-02 Horizontal Section Detail  
SCALE : NONE



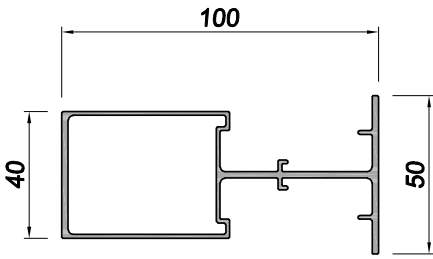

**IDCW00001**  
THK. 2.0 mm - 1.295 Kg/m

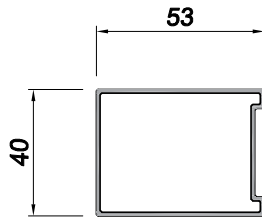

**IDCW00002**  
THK. 1.2 mm - 0.609 Kg/m

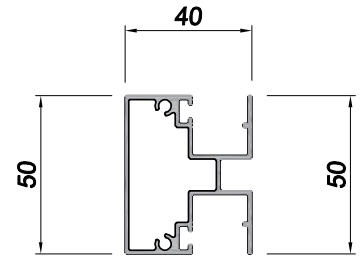

**IDCW00003**  
THK. 1.2 mm - 0.823 Kg/m

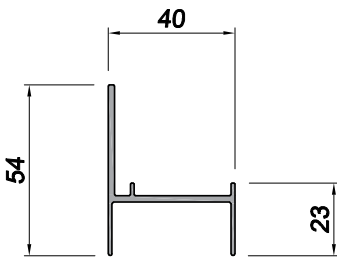

**IDCW00004**  
THK. 2.0 mm - 0.542 Kg/m

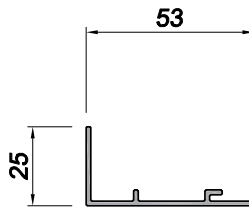

**IDCW00005**  
THK. 1.5 mm - 0.355 Kg/m

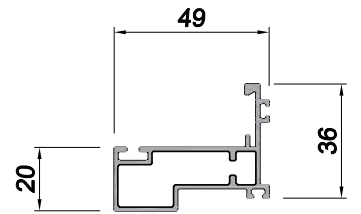

**IDCW00006**  
THK. 1.2 mm - 0.641 Kg/m

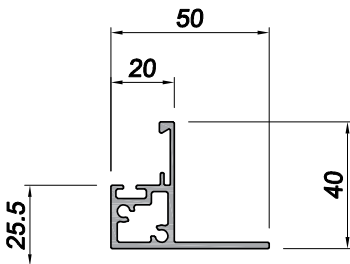

**IDCW00007**  
THK. 2.0 mm - 0.746 Kg/m

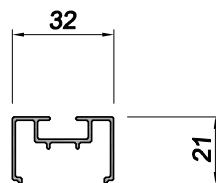

**IDCW00008**  
THK. 1.0 mm - 0.277 Kg/m

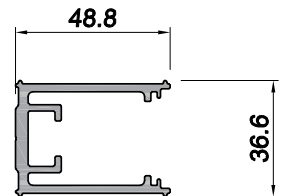

**IDCW00009**  
THK. 2.5 mm - 1.142 Kg/m

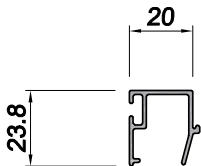

**IDCW00010**  
THK. 1.2 mm - 0.263 Kg/m

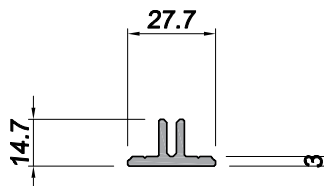

**IDCW00011**  
THK. 3.0 mm - 0.377 Kg/m

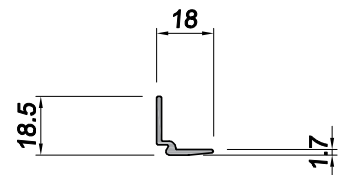

**IDCW00012**  
THK. 1.5 mm - 0.145 Kg/m

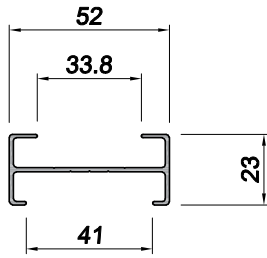

**IDGA00009**  
THK. 1.5 mm - 0.420 Kg/m

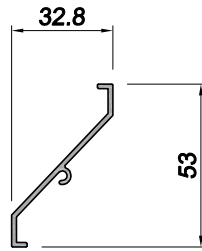

**IDGA00001**  
THK. 1.5 mm - 0.323 Kg/m

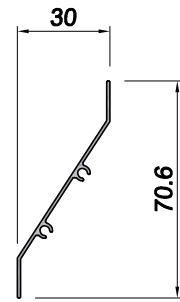

**IDGA00002**  
THK. 1.0 mm - 0.26 Kg/m

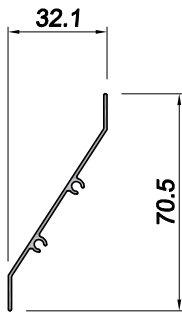

**IDGA00003**  
THK. 1.1 mm - 0.285 Kg/m

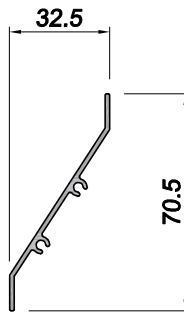

**IDGA00004**  
THK. 1.5 mm - 0.379 Kg/m

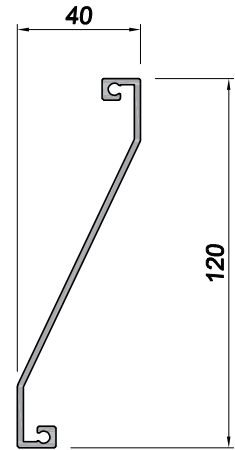

**IDGA00005**  
THK. 2.0 mm - 0.902 Kg/m

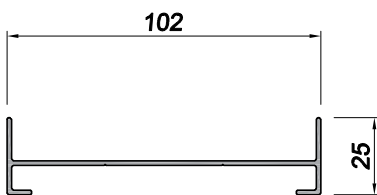

**IDGA00010**  
THK. 1.5 mm - 0.658 Kg/m

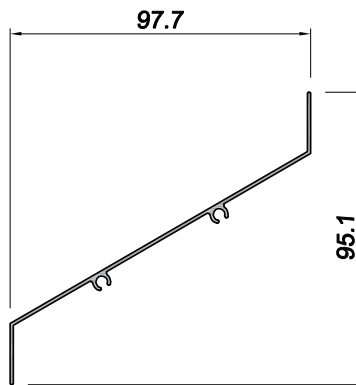

**IDGA00006**  
THK. 1.1 mm - 0.513 Kg/m

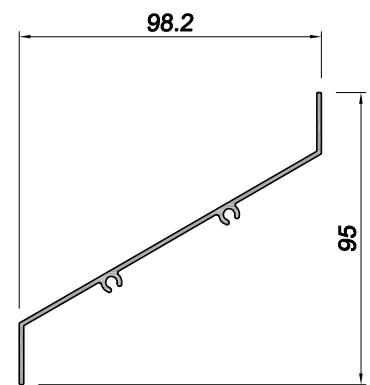

**IDGA00007**  
THK. 1.5 mm - 0.697 Kg/m

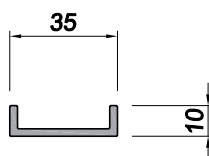

**IDGA00008**  
THK. 2.5 mm - 0.339 Kg/m

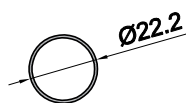

**IDPR00002**  
THK. 0.95 mm - 0.172 Kg/m

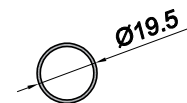

**IDPR00001**  
THK. 1.0 mm - 0.158 Kg/m

| Computational code | Main Category | Division | SUB | Markers        | EXPLAIN                               |
|--------------------|---------------|----------|-----|----------------|---------------------------------------|
| H 1                | MF            |          |     | H1=MF          | MILL FINISH                           |
| H 2                | CR            |          |     | H2=CR          | CHROMATE                              |
| H 3                | AD            | SiL      | S   | H3=AD-SiL-S    | ANODIZED SILVER SEALING               |
| H 4                | AD            | SiL      | M   | H4=AD-SiL-M    | ANODIZED SILVER MATT                  |
| H 5                | AD            | SiL      | C   | H5=AD-SiL-C    | ANODIZED SILVER CLEAR                 |
| H 5                | AD            | SiL      | W   | H6=AD-SiL-W    | ANODIZED SILVER ED(WHITE)             |
| H 6                | TN            | STN      | S   | H7=TN-STN-S    | ANODIZED TIN(SN) STAINLESS SEALING    |
| H 7                | TN            | STN      | M   | H8=TN-STN-M    | ANODIZED TIN(SN) STAINLESS MATT       |
| H 8                | TN            | STN      | C   | H9=TN-STN-C    | ANODIZED TIN(SN) STAINLESS CLEAR      |
| H 9                | TN            | BRZ      | S   | H10=TN-BRZ-S   | ANODIZED TIN(SN) BRONZE SEALING       |
| H 10               | TN            | BRZ      | M   | H11=TN-BRZ-M   | ANODIZED TIN(SN) BRONZE MATT          |
| H 11               | TN            | BRZ      | C   | H12=TN-BRZ-C   | ANODIZED TIN(SN) BRONZE CLEAR         |
| H 12               | TN            | BLK      | S   | H13=TN-BLK-S   | ANODIZED TIN(SN) BLACK SEALING        |
| H 13               | TN            | BLK      | M   | H14=TN-BLK-M   | ANODIZED TIN(SN) BLACK MATT           |
| H 14               | TN            | BLK      | C   | H15=TN-BLK-C   | ANODIZED TIN(SN) BLACK CLEAR          |
| H 15               | Ni            | STN      | S   | H16=Ni-STN-S   | ANODIZED NICKEL(NI) STAINLESS SEALING |
| H 16               | Ni            | STN      | M   | H17=Ni-STN-M   | ANODIZED NICKEL(NI) STAINLESS MATT    |
| H 17               | Ni            | STN      | C   | H18=Ni-STN-C   | ANODIZED NICKEL(NI) STAINLESS CLEAR   |
| H 18               | Ni            | BRZ      | S   | H19=Ni-BRZ-S   | ANODIZED NICKEL(NI) BRONZE SEALING    |
| H 19               | Ni            | BRZ      | M   | H20=Ni-BRZ-M   | ANODIZED NICKEL(NI) BRONZE MATT       |
| H 20               | Ni            | BRZ      | C   | H21=Ni-BRZ-C   | ANODIZED NICKEL(NI) BRONZE CLEAR      |
| H 21               | Ni            | BLK      | S   | H22=Ni-BLK-S   | ANODIZED NICKEL(NI) BLACK SEALING     |
| H 22               | Ni            | BLK      | M   | H23=Ni-BLK-M   | ANODIZED NICKEL(NI) BLACK MATT        |
| H 23               | Ni            | BLK      | C   | H24=Ni-BLK-C   | ANODIZED NICKEL(NI) BLACK CLEAR       |
| H 24               | AD            | GLD      | M   | H25=AD-GLD-M   | ANODIZED GOLD ED MATT                 |
| H 25               | AD            | GLD      | C   | H25=AD-GLD-C   | ANODIZED GOLD ED CLEAR                |
| H 26               | PW            | GN       |     | H27=PW-GN      | POWDER GENERAL                        |
| H 27               | PW            | 5Y       |     | H28=PW-5Y      | POWDER QUALITY GUARANTEE 5YEAR        |
| H 28               | PW            | 10Y      |     | H28=PW-10Y     | POWDER QUALITY GUARANTEE 10YEAR       |
| H 29               | PW            | 15Y      |     | H28=PW-20Y     | POWDER QUALITY GUARANTEE 15YEAR       |
| H 30               | WD            | GN       |     | H31=WD-GN      | POWDER WOOD GENERAL                   |
| H 31               | WD            | CW       |     | H32=WD-CW      | POWDER WOOD CURTAIN WALL              |
| H 32               | PV            | 2C       | GN  | H33=PV-2C-GN   | P.V.D.F 2COAR FROPON GENERAL          |
| H 33               | PV            | 2C       | CW  | H34=PV-2C-CW   | P.V.D.F 2COAT FROPON CURTAIN WALL     |
| H 34               | PV            | 3C       | GN  | H35=PV-3C-GN   | P.V.D.F 3COAT FROPON GENERAL          |
| H 35               | PV            | 3C       | CW  | H36=PV-3C-CW   | P.V.D.F 3COAT FROPON CURTAIN WALL     |
| H 36               | AD            | SiL      | S   | H37=S-AD-SiL-S | Shot B-ANODIZED SILVER SEALING        |
| H 37               | AD            | SiL      | M   | H38=S-AD-SiL-M | Shot B-ANODIZED SILVER MATT           |
| H 38               | AD            | SiL      | C   | H39=S-AD-SiL-V | Shot B-ANODIZED SILVER CLEAR          |

| U.S.A                                  |                   |
|--|-------------------|
| PROJECT NAME                           | PERIOD            |
| 1. Koll Center, Bellevue, WA           | Jan.1986-Jan.1987 |
| 2. 1420 5th Ave, Seattle               | Dec.1987-Jul.1988 |
| 3. 777 Tower L.A.C.A                   | Apr.1989-Oct.1989 |
| 4. Pioneer Place Portland Ore          | Dec.1988-Jun.1989 |
| 5. 550 South Hope Street               | Sep.1989-Feb.1990 |
| 6. Chicago Title Chicago ILL           | Jun.1986-Dec.1987 |
| 7. 3131 Eliot Seattle WA               | Jun.1986-Nov.1986 |
| 8. Brinderson Tower PH-1 Irvine        | Jun.1986-Oct.1986 |
| 9. Director's Guild Hollywood, CA      | Nov.1987-Feb.1988 |
| 10. Hutton Center, Santa CA            | Mar.1987-May.1987 |
| 11. Columbia Studio Plaza Burbank, CA  | Sep.1987-Dec.1989 |
| 12. 34W.Wacker Chicago, ILL            | Jun.1987-Mar.1988 |
| 13. Jamboree Center Irvine CA          | Mar.1987-Mar.1988 |
| 14. 865 Figueroa L.A.C.A               | Feb.1989-Nov.1989 |
| 15. Two Union SQ. Seattle, WA          | Apr.1988-Apr.1989 |
| 16. 100F Wisconsin                     | Sep.1988-Jan.1989 |
| 17. Jamboree Center Irvine, CA         | May.1990-Aug.1990 |
| 18. 600 Anton Bldg. L.A.CA             | Aug.1990-Nov.1990 |
| 19. Ladera Tower Condo Guam            | Nov.1992-Aug.1993 |
| 20. Chrysler H/Q Guam                  | Oct.1994-Jun.1995 |
| 21. First Hawaiian Center, Quam        | Oct.1994-Aug.1995 |
| 22. American Store H/Q Salt Lake, Utah | Dec.1995-Jul.1996 |
| 23. Fox studio Operation (NEB Bldg) LA | May.1999-Nov.1999 |
| 24. Alcoa World H/Q Pittsburgh, PA     | Apr.1997-Oct.1998 |
| 25. Lucent Chicago                     | Feb.1999-Oct.1999 |
| 26. Yeba Buena Sanfrancisco            | Feb.1999-Dec.1999 |
| 27. 110 Glendon Portland               | Jan.1999-Jun.1999 |
| 28. Millennium Tower Portland          | Oct.1999-Feb.2000 |
| 29. 640 5th Avenue                     | Mar.2002-Sep.2002 |
| 30. Calpers H/Q, CA                    | Mar.2003-Jan.2004 |
| 31. 2000 Avenue of the stars           | Oct.2004-Mar.2005 |
| 32. OHSU River Campus                  | Nov.2004-May.2005 |
| 33. The Eliot Tower At 10th            | Feb.2005-Jun.2005 |
| 34. At Water Tower, Portland           | Apr.2006-Jan.2007 |
| 35. One Museum Park, Chicago           | Apr.2006-Apr.2007 |
| 36. San Jose Condominium, CA           | Jul.2006-Jan.2007 |
| 37. UW Medical Center, WA              | Jul.2007-Jan.2008 |
| 38. 555 Mission Street, CA             | Jan.2007-Jun.2007 |

| China (Including HongKong, Taiwan, Macau)        |                   |
|--|-------------------|
| PROJECT NAME                                     | PERIOD            |
| 1. Kowloon Park Bldg                             | Jan.1988-Feb.1989 |
| 2. Government Office Building Phase2, HongKong   | Feb.1988-Jul.1989 |
| 3. Government Office Building Phase3, HongKong   | Sep.1988-Jan.1989 |
| 4. Tai Shou Office Bldg, Taiwan                  | Dec.1991-Mar.1992 |
| 5. Park Lane Square Bldg, HongKong               | May.1992-Feb.1993 |
| 6. Jaffe Road, HongKong                          | May.1992-Oct.1992 |
| 7. Peninsula Hotel, HongKong                     | Oct.1992-Jul.1993 |
| 8. East Point center, HongKong                   | Oct.1992-Jul.1993 |
| 9. Taicom Building, Taiwan                       | Oct.1992-Dec.1993 |
| 10. Fubon Banking Center, Taiwan                 | Oct.1992-Dec.1993 |
| 11. Tai Kai Building, Taiwan                     | Dec.1992-Aug.1993 |
| 12. Far East World Center, Taiwan                | Dec.1992-Sep.1993 |
| 13. Chinan Hotel                                 | Oct.1994-Mar.1995 |
| 14. World Plaza, Shanghai                        | Mar.1995-Mar.1997 |
| 15. King Hip Building, Shenzhen                  | Mar.1995-Jun.1996 |
| 16. International Trading Center, Shenzhen       | Mar.1995-Mar.1996 |
| 17. World Finance Tower, Shanghai                | Oct.1995-Aug.1997 |
| 18. Industrial Commercial Bank of China, Beijing | Oct.1995-Aug.1997 |
| 19. POS-Plaza Pudong, Shanghai                   | Apr.1997-Dec.1998 |
| 20. Jingyin Mansion Build, Pudong                | May.1997-Jan.1998 |
| 21. Pudong Government Building, Pudong, Shanghai | May.1997-Jun.1998 |
| 22. Macau Tower, Macau                           | Mar.1999-Nov.1999 |
| 23. Hyundai Center (Beijing)                     | Oct.1999-Jan.2000 |
| 24. South Pacific Hotel, Shanghai                | Oct.1999-Feb.2000 |
| 25. Macau entertainment, Macau                   | Sep.1999-Dec.2000 |
| 26. Beijing International Club                   | May.2000-Sep.2001 |
| 27. Taishin Bank Tower, Taishin, Taiwan          | Aug.2003-May-2004 |

## CÔNG TRÌNH ĐÃ LÀM Ở NƯỚC NGOÀI

### In Others

| PROJECT NAME                                  | PERIOD            |
|---|-------------------|
| 1. Bayshore Resort Pa, Condominium, Singapore | Feb.1985-Jun.1986 |
| 2. Brega New Town Complex Brega, Libya        | Mar.1988-Aug.1990 |
| 3. Asian Development Bank, Philippines        | Jul.1988-Jul.1990 |
| 4. Metrotown Eaton, Canada                    | Oct.1988-Feb.1989 |
| 5. Eaton Center, Canada                       | Oct.1988-Feb.1989 |
| 6. 120 Collins St.Australia                   | Nov.1989-May.1990 |
| 7. Indocasa Building, Spain                   | Nov.1991-Feb.1993 |
| 8. Fomento, Spain                             | Jul.1992-Oct.1992 |
| 9. Holiday Inn Tower, Nagoya, Japan           | Jul.1989-Dec.1989 |
| 10. NTT Shinjuku H/Q, Tokyo, Japan            | Dec.1993-Apr.1994 |
| 11. Tokyo Int'l Forum, Tokyo, Japan           | Sep.1994-Dec.1994 |
| 12. Kanakawa Office Bldg, Kana, Japan         | Oct.1994-Apr.1995 |
| 13. Proyecto Bouchard, Argentina              | Sep.1995-Jul.1996 |
| 14. I.C.E.C H/Q, Manila, Philippines          | Nov.1996-Jul.1997 |
| 15. Hyundai Building, Russia                  | Feb.1996-May.1997 |
| 16. 18 Stories, Quatar                        | Oct.1995-Dec.1996 |
| 17. Atago, Tokyo, Japan                       | Oct.1999-Oct.2000 |
| 18. PBCOM Office Tower, Manila, Philippines   | Mar.1999-Mar.2000 |
| 19. Four Seasons Hotel, Egypt                 | Jan.2002-Sep.2004 |
| 20. Sydney Hilton Hotel, Sydney               | Jul.2003-Apr.2004 |
| 21. One Raffles Quay, Singapore               | Dec.2003-Dec.2005 |
| 22. Emirates Office Tower, Dubai, UAE         | Completed         |
| 23. Trio and Cyber Tower, Mianmar             | Jan.2014-Jul.2014 |

### Vietnamese

| PROJECT NAME                             | PERIOD            |
|--|-------------------|
| 1. Keangnam Ha Noi Lanmark Tower, Ha Noi | Jan.2009-Mar.2011 |
| 2. Mipec Tower, Ha Noi                   | Jun.2010-May.2011 |
| 3. Splendora New city 1st, Ha Noi        | Apr.2011-Nov.2011 |
| 4. Detech Tower, Ha Noi                  | May.2011-Aug.2011 |
| 5. Hills State, Ha Noi                   | Jun.2012-May.2013 |
| 6. Lancaster Ha Noi, Ha Noi              | Jun.2012-Dec.2013 |
| 7. SEVT Factory (Samsung), Thai Nguyen   | Nov.2013-Feb.2014 |
| 8. Le Truc Tower, Ha Noi                 | Apr.2015-Jul.2016 |
| 9. Tay Ho Tay Urban, Ha Noi              | Nov.2016-Nov.2017 |
| 10. SDV Factory (Samsung), Bac Ninh      | Nov.2016-Nov.2017 |
| 11. Discovery Tower, Ha Noi              | May.2016-Jan.2018 |
| 12. Lanmark 81 Tower, Ho Chi Minh        | Nov.2016-Jan.2019 |

| Korean                                       |                    |
|--|--------------------|
| PROJECT NAME                                 | PERIOD             |
| 1. Dae-Han Life Insurance Office Bldg, Seoul | Feb.1983-Nov.1984  |
| 2. Eulgi-ro Redeveloping Bldg.(PPC) Seoul    | Nov.1985-Jul.1987  |
| 3. Law Enforcement Head Office               | Feb.1986-Feb.1987  |
| 4. Hanmoo Hotel                              | Feb.1986-Mar.1987  |
| 5. Lotte Hotel, Seoul                        | Aug.1986-Jul.1987  |
| 6. Rivera Hotel, Seoul                       | Jan.1987-Mar.1988  |
| 7. Korea Trade Center Office Bldg, Seoul     | Apr.1987-Apr.1988  |
| 8. Ramada Renaissance Hotel, Seoul           | Jan.1987-May.1988  |
| 9. Intercontinental Hotel, Seoul             | Apr.1987-Mar.1989  |
| 10. Korea Broadcasting Station Bldg, Seoul   | Jan.1987-Mar.1988  |
| 11. Botanical Garden, Che-ju Island          | Dec.1988-Dec.1991  |
| 12. Korea Textile Center, Seoul              | Sep.1989-Jul.1990  |
| 13. Kyung Ki Bank HQ Bldg, Incheon           | Dec.1989-Jul.1991  |
| 14. Marine Center, Busan                     | Jul.1989-Jul.1991  |
| 15. Sambo HQ Office Bldg, Seoul              | Dec.1989-Jul.1991  |
| 16. Saieiung Officetel, Seoul                | Oct.1989-Dec.1990  |
| 17. Pacific Security Office Bldg, Busan      | Oct.1989-Oct.1990  |
| 18. Che-ju Miwon Bldg, Cheju Island          | Oct.1989-Oct.1990  |
| 19. Cosmos Officetel, Seoul                  | Oct.1989-Mar.1991  |
| 20. Sando Bldg, Seoul                        | Jan.1989-Aug.1990  |
| 21. Yusung Hyundai Resortel, Seoul           | Nov.1989-Oct.1991  |
| 22. Nam seoul Country, Seoul                 | Jul.1989-Jun.1991  |
| 23. Mukyo-dong Hyundai Bldg, Seoul           | Aug.1989-Dec.1990  |
| 24. Crystal Beach Office Tower, Busan        | Aug.1989-Dec.1990  |
| 25. Hyundai Marine Insurance Bldg, Busan     | Jan.1989-Aug.1990  |
| 26. Hyun-seo Bldg, Seoul                     | Dec.1989-Oct.1990  |
| 27. Hyundai Marine Insurance Bldg, Seoul     | Jan.1989-Jun.1991  |
| 28. Sung Dam Bldg, Seoul                     | Jan.1990-Aug.1991  |
| 29. Asia Cement Office Bldg                  | Jan.1990-Feb.1991  |
| 30. Sunghnam Daehan Ins Bldg                 | Apr.1990-Jun.1991  |
| 31. Samho Mulsan Officetel, Seoul            | Jan.1991-Jun.1991  |
| 32. Hyundai High Lan Officetel, Seoul        | Apr.1991-Jul.1991  |
| 33. Hanksan Officetel Bldg Pohang            | Mar.1991-Oct.1991  |
| 34. Dongrae Hotel, Busan                     | Jul. 1990-Mar.1991 |
| 35. Ulsan Daehan Life Insurance Bldg         | Oct.1991-Mar.1992  |
| 36. Daehan Investment Trust                  | Mar.1992-Dec.1993  |
| 37. Seoul Security Bldg, Seoul               | Nov.1992-Oct.1993  |
| 38. Jeil Security Bldg, Seoul                | May.1992-Dec.1993  |
| 39. Public Prosecutor's Office Bldg          | Jun.1993-Jun.1994  |
| 40. Oil Development Center                   | Aug.1993-Jun.1994  |

| Korean   |                   |
|--|-------------------|
| PROJECT NAME   | PERIOD            |
| 41. Posco Head Office Bldg                             | Jul.1993-Feb.1994 |
| 42. Busan Lotte Bldg, Busan                            | Jan.1994-Dec.1996 |
| 43. Dadong Bldg, Seoul                                 | Jan.1995-Aug.1996 |
| 44. Dogokdong Character Bldg, Seoul                    | Jul.1995-Apr.1996 |
| 45. Jamsil Sigma Bldg                                  | Feb.1995-Mar.1996 |
| 46. Busan City Hall Bldg, Busan                        | Mar.1995-Mar.1997 |
| 47. Daerim Acrovill, Seoul                             | Oct.1998-Dec.1999 |
| 48. Doosan Heavy Industrial Bldg                       | Oct.1995-Oct.1997 |
| 49. Yeido Evangelical Center                           | Mar.1996-Oct.1997 |
| 50. Hansol Head Office Building                        | Dec.1996-Oct.1997 |
| 51. Dongbu HQ Bldg, Seoul                              | Aug.1996-Oct.1997 |
| 52. Government Bldg, Phrase3, Seoul                    | Nov.1996-Dec.1997 |
| 53. Professional Const Bldg, Seoul                     | Dec.1996-Dec.1997 |
| 54. Woosung Character 199                              | Nov.1996-Jul.1997 |
| 55. Private Seoul Pension Center                       | May.1996-Feb.1998 |
| 56. Korea Economic Newspaper Bldg                      | Jun.1996-Oct.1997 |
| 57. I-Tower Bldg, Seoul                                | Nov.1996-Apr.2001 |
| 58. Korea Broadcasting Office Bldg                     | Jan.1997-Jan.1998 |
| 59. Chongro Tower, Seoul                               | Feb.1997-Mar.1999 |
| 60. Nasan Suite III, Seoul                             | Mar.1997-Dec.1997 |
| 61. Techno Mart, Seoul                                 | Jan.1997-Aug.1998 |
| 62. Hyunda Parkvill, Seoul                             | Jul.1997-Dec.1999 |
| 63. Hyundai Marine Insurance Bldg Daegu                | Feb.1998-Oct.1999 |
| 64. Mokdong Grand Tower, Seoul                         | Feb.1999-Feb.2001 |
| 65. Bexco, Busan                                       | Nov.1999-Dec.2000 |
| 66. Gi-Jang City Hall                                  | Feb.1999-Jan.2000 |
| 67. Hyundai Marine Insurance Bldg Ulsan                | Mar.1999-Oct.2000 |
| 68. District Public Prosecutor Office, Busan           | Oct.1999-May.2001 |
| 69. Incheon International Airport                      | Nov.1999-Dec.2000 |
| 70. Han Wha Bldg, Seoul                                | Jan.2000-Mar.2001 |
| 71. Mokdong Hyperion I, Seoul                          | Jul.2001-Apr.2003 |
| 72. Seo-cho Bldg, Seoul                                | Mar.2002-Jul.2003 |
| 73. Hyun Mareine Insurance HQ Bldg, Seoul (Renovation) | Dec.2002-Oct.2003 |
| 74. Daewoo Marine Technical Center                     | Oct.2002-May.2003 |
| 75. Chunho-dong Theme Bldg, Seoul                      | Dec.2002-Dec.2003 |
| 76. Dae-rim Acrovista, Seoul                           | Jun.2002-Nov.2004 |
| 77. Qwangjang-dong Officetel                           | Jan.2003-Sep.2003 |
| 78. Korea Cable technical Lab, Quangju                 | Jan.2003-May.2004 |
| 79. Busan Benecity, Busan                              | Aug.2003-Dec.2004 |
| 80. Yong-san Private Station Bldg II, Seoul            | Aug.2003-Apr.2004 |

# CÔNG TRÌNH ĐÃ LÀM Ở HÀN QUỐC

| Korean       |        |
|--------------|--------|
| PROJECT NAME | PERIOD |

|  |                   |
|--|-------------------|
| 81. Galwoldong Oficetel                            | Apr.2003-Aug.2004 |
| 82. Yoeuido Lotte CastlelVY, Seoul                 | Jun.2003-May.2005 |
| 83. Bundang Jungja-dong Pavilion, Gyunggi-do       | Jan.2003-Mar.2004 |
| 84. Yong-San Station Private Bldg III, Seoul       | Aug.2003-Apr.2004 |
| 85. Sunreung Acrotel, Seoul                        | Jul.2003-Oct.2004 |
| 86. Mok-dong Netville, Seoul                       | Jun.2003-Dec.2003 |
| 87. KCC Park Towon                                 | Mar.2004-Aug.2004 |
| 88. Mok-dong Hyperion II, Seoul                    | May.2004-Jun.2004 |
| 89. Pyeongchon Venturedigm, Gyunggi-do             | Oct.2005-Mar.2006 |
| 90. Beomil-dong Poseidon, Busan                    | Oct.2005-Dec.2006 |
| 91. Haeundae Poseidon, Busan                       | Oct.2005-Dec.2006 |
| 92. Hangangno Complex Bldg, Seoul                  | May.2005-Oct.2007 |
| 93. Jung-dong We've The State, Gyunggi-do          | Nov.2005-Sep.2006 |
| 94. Korea University Guro Hospital, Seoul          | Sep.2005-Jul.2007 |
| 95. Best Western Hotel, Seoul                      | Dec.2005-Mar.2007 |
| 96. Bundang Cha Hospital, Gyeonggi-do              | Dec.2005-Sep.2006 |
| 97. KD Villant II, Seoul                           | Jan.2006-Dec.2006 |
| 98. Haeundae Sentum City, Busan                    | May.2006-Dec.2008 |
| 99. Busan Aqua Palace, Busan                       | Apr.2006-Dec.2007 |
| 100. Cheonho Brown Stone, Seoul                    | May.2006-Jul.2007 |
| 101. Posco International Center, Busan             | Sep.2006-Dec.2006 |
| 102. Daehyeon 2 Zone Reconstruction Apt Seoul      | Sep.2006-Apr.2007 |
| 103. Sangok Lotte Mart, Incheon                    | Aug.2006-Apr.2007 |
| 104. Mapo Lotte Castle, Seoul                      | Nov.2006-Feb.2009 |
| 105. Ulsan 2nd Provincial Office, Ulsan            | Apr.2007-Dec.2008 |
| 106. Anyang Doosan Venture Digm, Gyeonggi-do       | Jan.2007-Sep.2007 |
| 107. Dongcheon-dong Complex Center, Daegu          | Feb.2007-Aug.2007 |
| 108. Busan University Hospital, Yangsan            | Apr.2007-Nov.2008 |
| 109. The 2nd Busan University Hospital, Yangsan    | Jun.2008-Dec.2010 |
| 110. Busan University Children's Hospital, Yangsan | Jun.2007-Jul.2008 |
| 111. Dongnae Lotte Mart, Busan                     | May.2007-Feb.2008 |
| 112. Namcheon Samick Reconstruction Apt Busan      | Jun.2007-Feb.2009 |
| 113. Sinjeong-dong We've The Zenith, Ulsan         | Jun.2007-Feb.2010 |
| 114. Sajik-dong We've The Zenik, Cheongju          | Jun.2007-Jul.2009 |

| Korean       |        |
|--------------|--------|
| PROJECT NAME | PERIOD |

|   |                   |
|---|-------------------|
| 115. Incheon National Airport Human Resources Devolpment Center | Aug.2007-Jul.2008 |
| 116. Northeast Asia Trade Tower, Incheo                         | Dec.2007-Oct.2009 |
| 117. Hynix A-Project, Cheongju                                  | Aug.2007-Jun.2008 |
| 118. Masan I'Park, Masan  | May.2008-Dec.2009 |
| 119. Seomyeon The# Centralstar, Busan                           | Jan.2008-May.2011 |
| 120. Sogong-dong Lotte Hotel Remodeling, Seoul                  | Aug.2007-Sep.2009 |
| 121. Cheongnyangni Private Railroad Station Bldg, Seoul         | Jul.2008-Aug.2010 |
| 122. Adena Tower, Seoul   | Jul.2008-Feb.2009 |
| 123. NHN Venture Tower, Bundang                                 | Mar.2008-Jun.2009 |
| 124. Yongin Light Rail Transit, Gyeonggi-c                      | Sep.2008-Jun.2009 |
| 125. Pentaport, Asan  | Mar.2009-Oct.2011 |
| 126. Posco Global R&D Center, Incheon                           | May.2009-May.2010 |
| 127. Sondo Hillstate, Incheon                                   | Jul.2009-Jan.2011 |
| 128. Sindorim D-cubecity, Seoul                                 | Mar.2010-Jun.2011 |
| 129. Sondo Global University Campus, Incheon                    | Apr.2010-Aug.2011 |
| 130. Yeouido Park 1 (Tower 2), Seoul                            | May.2010-Jan.2012 |
| 131. Yangpyung Sungwoo Ostar, Gyunggi-do                        | Jul.2010-Dec.2011 |
| 132. Yeouido Park 1 Hotel, Seoul                                | Oct.2010-May.2012 |







## MIỀN BẮC

### 1. Công Ty TNHH Tư Vấn Thiết Kế và Đầu Tư Xây Dựng Liên Hoa

Địa chỉ: Số 2, Khu đất dịch vụ 1 Xa la, P.Phúc La, Q.Hà Đông, Hà Nội  
Điện thoại: 0248.588.4858 / 0904.080.038

### 2. Công Ty TNHH Nhôm Gia Thịnh

VPGD: Ngã ba Pháp Vân-Yên Sở, Hoàng Mai, Hà Nội  
Điện thoại: 0966.610.900 / 0904.299.833 / 094.557.5532

### 3. Công Ty TNHH Sản Xuất và Thương Mại Tiến Lượng

Địa chỉ: 222, Phạm Văn Đồng, PCổ Nhuế 2, Q.Bắc Từ Liêm, Hà Nội  
Điện Thoại: 0243.755.4880 / 0981.767.930

### 4. Công Ty CP Đầu Tư Xây Lắp Xuất Nhập Khẩu Hùng Vương

Địa chỉ: Số 57, Vĩnh Phúc, P.Vĩnh Phúc, Q.Ba Đình, Hà Nội  
Điện Thoại: 0243.791.7517 / 0988.768.186

### 5. Công Ty TNHH Jeil Panel Vina

Địa chỉ: Xã Trung Hưng, H.Yên Mỹ, T.Hung Yên  
Điện Thoại: 02213.580.030

### 6. Công Ty TNHH SK-Tech

Địa chỉ: 999 Ngô Gia Tự, P.Đức Giang, Q.Long Biên, Hà Nội  
Điện Thoại: 0243.652.7048

### 7. Công Ty TNHH Xây Dựng SEMO Việt Nam

Địa chỉ: Km9, Đại lộ Thăng Long, xã An Khánh, H.Hoài Đức, Hà Nội  
Điện Thoại: 0243.795.7380

## MIỀN TRUNG

### 8. Công Ty TNHH Kim Gia Khang

Địa Chỉ: Số 16 đại lộ Võ Chí Công, Q.Cẩm Lệ, Đà Nẵng  
Điện Thoại: 0236.369.5056 / 0888.096.969

## MIỀN NAM

### 9. Công Ty TNHH Thái Bình An Phú Thịnh

Địa chỉ: Số B1, KP4, đường Đồng Khởi, P.Tân Hiệp, TP.Biên Hòa, Đồng Nai  
Điện Thoại: 0251.3828.649 / 0978.696.565

### 10. Công ty TNHH Elim Việt Nam

Địa chỉ: D81 Bis, quốc lộ 22, ấp Mỹ Hòa 2, xã Xuân Thới Đông, huyện Hóc Môn, TP.Hồ Chí Minh  
Điện Thoại: 0283.620.0490

### 11. Công Ty TNHH MTV Cửa và Cửa sổ More Than Gold

Địa Chỉ: 647, quốc lộ 13, P.Hiệp Bình Phước, Q.Thủ Đức, Hồ Chí Minh  
Điện Thoại: 0283.727.2341 - 0274.656.4651

### 12. Công Ty TNHH Jeil

Địa chỉ: B6/4A ấp 2, xã Tân Kiên, H.Bình Chánh, HCM  
Điện Thoại: 0286.270.8899

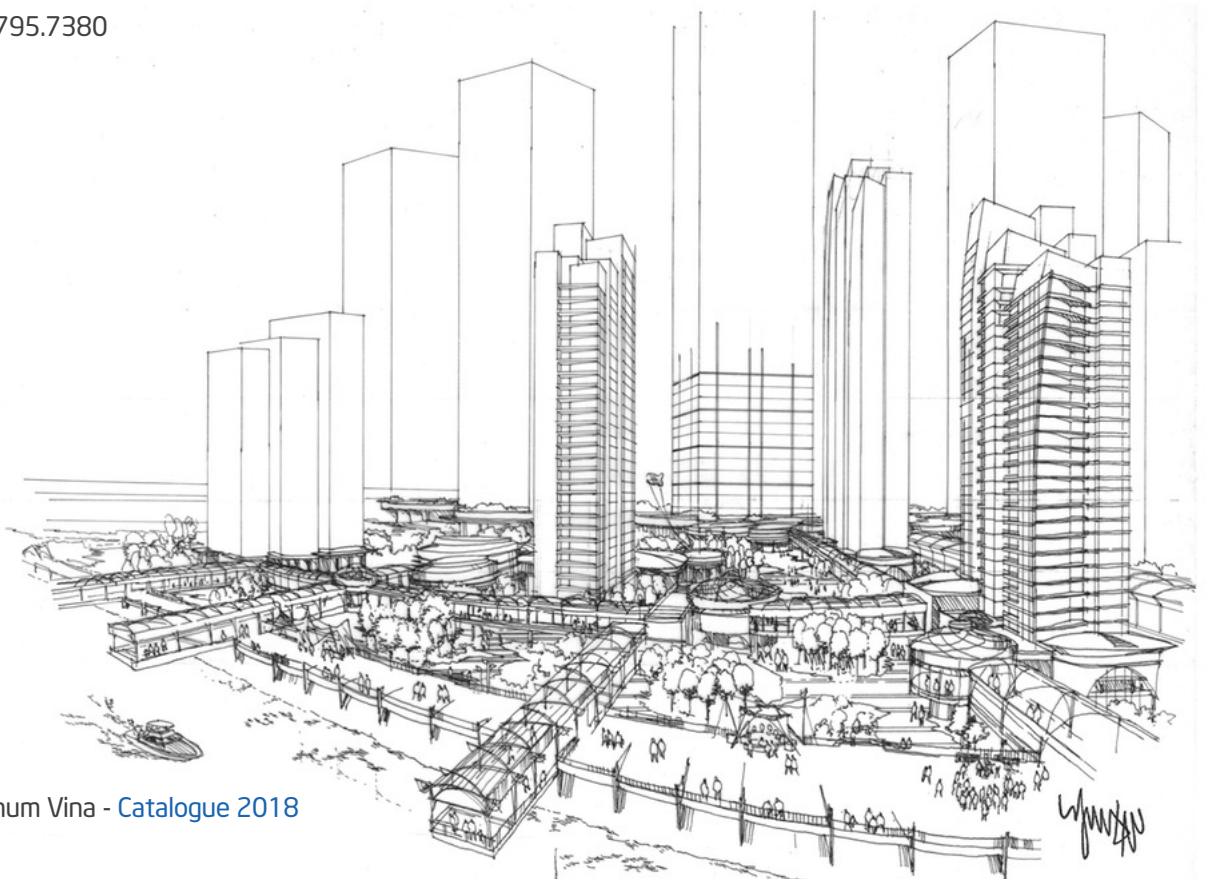



## **WARNING**

**Toàn bộ hình ảnh, nội dung và bản quyền thiết kế trong quyển catalogue này thuộc quyền sở hữu của công ty cổ phần Hyundai Aluminum Vina.**

**Mọi hành vi sao chép, thương mại hóa nội dung trong catalogue mà không có sự thỏa thuận trước với bên Hyundai Aluminum Vina sẽ bị truy tố trước pháp luật**



## QUÝ KHÁCH VUI LÒNG KIỂM TRA NHÃN MÁC HYUNDAI ALUMINUM VINA

Nhằm đảm bảo quyền lợi người tiêu dùng, toàn bộ sản phẩm đều được in mác điện tử đặc biệt chứng nhận nguồn gốc của sản phẩm

### HYUNDAI ALUMINUM VINA

Technology for a better tomorrow

#### 1. Hyundai Aluminum Vina

Đường B2, khu B, KCN Phố Nối A, xã Lạc Hồng, huyện Văn Lâm, tỉnh Hưng Yên, Việt Nam  
Điện thoại: 0221.396.7771~5 \* Fax: 0221.396.7770

#### 2. Alutec Vina

Lô CN6, KCN Điểm Thủy, xã Điểm Thủy, Huyện Phú Bình, tỉnh Thái Nguyên, Việt Nam  
Điện thoại: 0208.3931.535

#### 3. ALK Vina

Lô CN6-1,3, KCN Điểm Thủy, xã Hồng Tiến, tx Phổ Yên, tỉnh Thái Nguyên, Việt Nam

#### 4. KPTU Vina

Lô CN6, KCN Điểm Thủy, xã Điểm Thủy, Huyện Phú Bình, tỉnh Thái Nguyên, Việt Nam

#### 5. Văn phòng Hà Nội

Tầng 13, khối A tòa nhà Sông Đà, Phạm Hùng, phường Mỹ Đình 1, quận Nam Từ Liêm, Hà Nội  
Web: [hyundaial.co.kr](http://hyundaial.co.kr)

